

Farm King

OPERATOR AND PARTS MANUAL

Grain Cleaner

Model 362

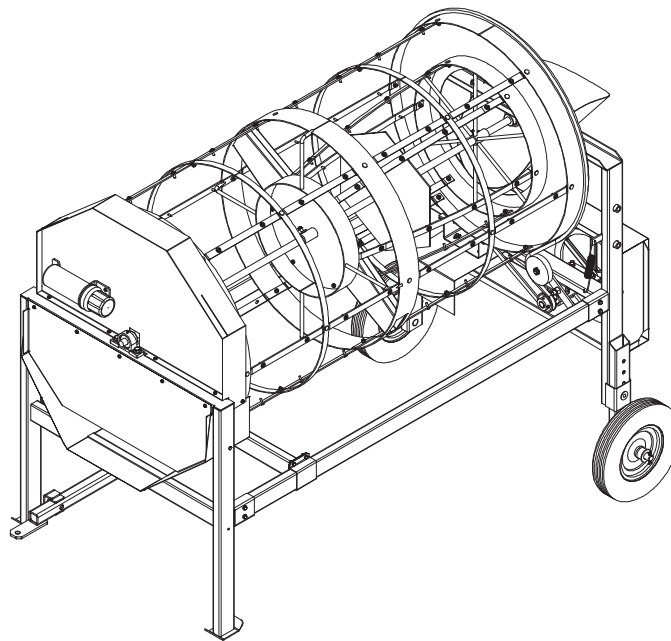

Table Of Contents

Manufacturer’s Statement: For technical reasons, Buhler Industries Inc. reserves the right to modify machinery design and specifications provided herein without any preliminary notice. Information provided herein is of descriptive nature. Performance quality may depend on soil fertility, applied agricultural techniques, weather conditions, and other factors.

- Warranty Registration Form.....1
- Introduction.....3
 - Owner’s Information.....5
 - Equipment Identification.....6
- Safety.....7
 - Safety Instructions.....9
 - Fire Prevention.....11
 - Equipment And Safety Signs (Decals).....13
 - Safety Sign-Off Form.....15
- Assembly.....17
 - Preparing For Assembly.....19
 - Frame Assembly.....20
 - Wheel Assembly.....20
 - Pulley Assembly.....22
 - Motor Assembly (Motor Not Supplied).....22
 - Belt Routing.....22
 - Front Guard Assembly.....24
 - Rear Guard Assembly.....24
 - Drum Assembly.....24
- Operation.....27
 - Pre - Operation Checklist.....29
 - Theory Of Operation.....30
 - Transporting.....31
- Maintenance.....33
 - Service Schedule.....35
 - Lubrication.....36
 - Belt Tension.....37
 - Tire Pressure.....37
 - Safety Sign (Decal) Installation.....38
 - Storage And Return To Service.....38

Parts Identification	39
General Parts Information.....	40
Hitch.....	40
Wheels.....	41
Frame.....	42
Guards.....	44
Pulleys.....	46
Drum And Screen.....	48
Utility Auger.....	50
Utility Auger Mount.....	52
Specifications And Shipping Kit Numbers	55
Specifications.....	57
Shipping Kit And Bundle Numbers.....	57
Hardware Torque Values.....	58
Warranty	61
Farm King Base Limited Warranty.....	63

Warranty Registration Form

This form must be filled out by the dealer and signed by both the dealer and the customer at the time of delivery.

Customer Name:	
Customer Address:	
City:	Prov / State:
Postal / Zip Code:	Phone:

Dealer Name:	
Dealer Address:	
City:	Prov / State:
Postal / Zip Code:	Phone:

Equipment Model:	Serial Number:	Delivery Date:
------------------	----------------	----------------

I have thoroughly instructed the buyer on the above described equipment which review included the Operator and Parts Manual content, equipment care, adjustments, safe operation and applicable warranty policy.

Dealer Inspection Report

- Bearings Turn Freely
- Belt Tension Checked
- All Fasteners Are Tight
- Lubricate Machine

Safety

- Safety Chain On Hitch
- All Decals Installed
- Guards And Shields Installed And Secure
- Review Operating And Safety Instructions

Date:	Dealer Rep. Signature:
-------	------------------------

The above equipment and Operator And Parts Manual have been received by me and I have been thoroughly instructed as to care, adjustments, safe operation and applicable warranty policy.

Date:	Customer / Owner Signature:
-------	-----------------------------

Remove this Warranty Registration Form from the Operator And Parts Manual. Make two copies of the form. Send original Warranty Registration Form to Farm King. Give one copy to the customer and the dealer will keep one copy.

Farm King



Introduction

This Operator And Parts Manual was written to give the owner / operator instructions on the safe operation, maintenance and part identification of the Farm King equipment. **READ AND UNDERSTAND THIS OPERATOR AND PARTS MANUAL BEFORE OPERATING YOUR FARM KING EQUIPMENT.** If you have any questions, see your Farm King dealer. This manual may illustrate options and accessories not installed on your Farm King equipment.

Owner’s Information..... 5
 Serial Number Location..... 5
 Manual Storage..... 5
Equipment Identification..... 6
 Component Location..... 6

Farm King



Owner's Information

Thank you for your decision to purchase a Farm King Grain Cleaner. To ensure maximum performance of your equipment, it is mandatory that you thoroughly study the Operator and Parts Manual and follow the recommendations. Proper operation and maintenance are essential to maximize equipment life and prevent personal injury.

Operate and maintain this equipment in a safe manner and in accordance with all applicable local, state, and federal codes, regulations and / or laws. Follow all onproduct labeling and instructions.

Make sure that all personnel have read this Operator and Parts Manual and thoroughly understand safe and correct operating, installation and maintenance procedures.

Farm King is continually working to improve its products. Farm King reserves the right to make any improvements or changes as deemed practical and possible without incurring any responsibility or obligation to make any changes or additions to equipment sold previously.

Although great care has been taken to ensure the accuracy of this publication, Farm King, makes no warranty or guarantee of any kind, written or expressed, implied or otherwise with regard to the information contained within this manual. Farm King assumes no responsibility for any errors that may appear in this manual and shall not be liable under any circumstances for incidental, consequential or punitive damages in connection with, or arising from the use of this manual.

Keep this manual available for frequent reference. All new operators or owners must review the manual before using the equipment and annually thereafter. Contact your Farm King Dealer if you need assistance, information, or additional copies of the manual. Visit our website at www.farm-king.com for a complete list of dealers in your area.

The directions left, right, front and rear, as mentioned throughout this manual, are as viewed from the rear of the equipment.

Serial Number Location

Please enter the model and serial number in the space provided for easy reference.

Figure 1

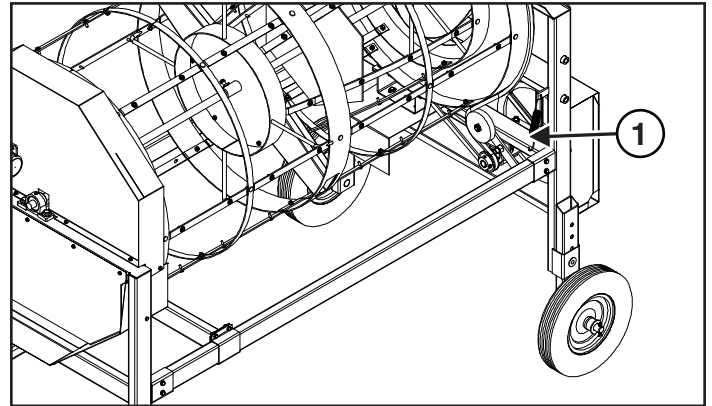

Model Number: _____

Serial Number: _____

The serial number plate (Item 1) [Figure 1] is located on the rear frame.

Always use your serial number when requesting information or when ordering parts.

Manual Storage

Figure 2

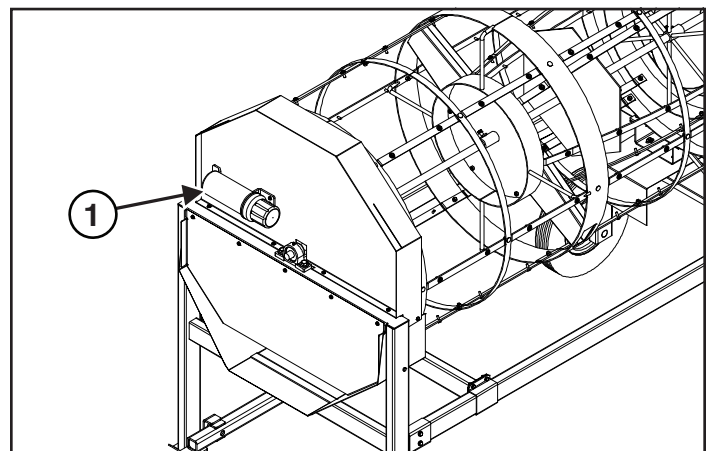

The operator and parts manual and other documents can be stored in the canister (Item 1) [Figure 2].

Equipment Identification

Component Location

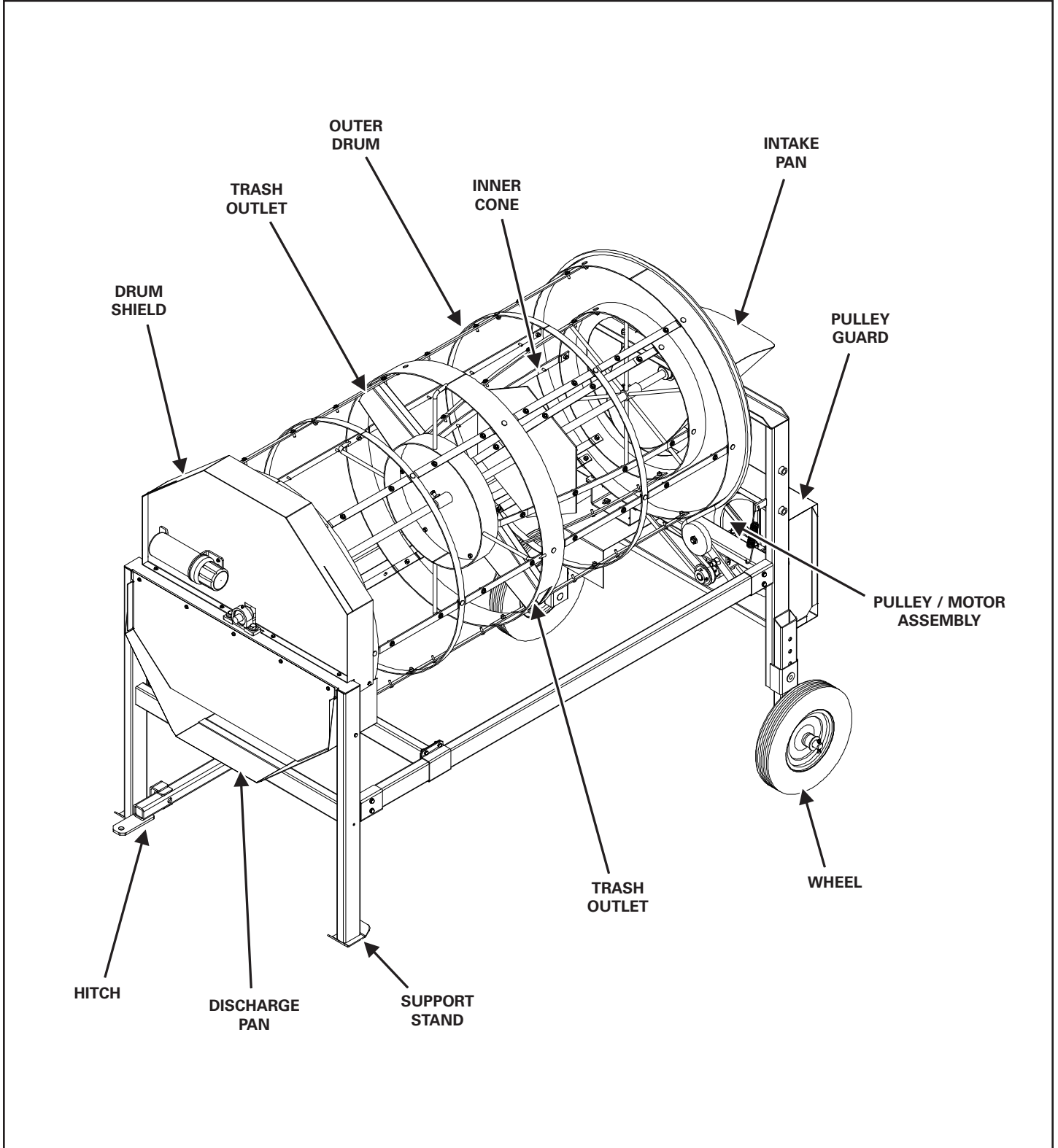

Safety

- Safety Instructions..... 9
 - Safe Operation is The Operator’s Responsibility..... 9
 - Safe Operation Needs A Qualified Operator..... 9
 - Use Safety Rules..... 10
 - Machine Requirements And Capabilities..... 10
 - Transport Safety..... 11
- Fire Prevention..... 11
 - Maintenance..... 11
 - Operation..... 11
 - Starting..... 11
 - Electrical..... 12
 - Hydraulic System..... 12
 - Fueling..... 12
 - Fire Extinguishers..... 12
- Equipment And Safety Signs (Decals)..... 13
- Safety Sign-Off Form..... 15

Farm King





Safety Instructions

Safe Operation is The Operator's Responsibility

	Safety Alert Symbol
<p>This symbol with a warning statement means: "Warning, be alert! Your safety is involved!" Carefully read the message that follows.</p>	

	CAUTION
<p>The signal word CAUTION on the machine and in the manuals indicates a potentially hazardous situation which, if not avoided, may result in minor or moderate injury. It may also be used to alert against unsafe practices.</p>	

	DANGER
<p>The signal word DANGER on the machine and in the manuals indicates a hazardous situation which, if not avoided, will result in death or serious injury.</p>	

	WARNING
<p>The signal word WARNING on the machine and in the manuals indicates a potentially hazardous situation which, if not avoided, could result in death or serious injury.</p>	

	IMPORTANT
<p>This notice identifies procedures which must be followed to avoid damage to the machine.</p>	

Safe Operation Needs A Qualified Operator

	WARNING
<p>Operators must have instructions before operating the machine. Untrained operators can cause injury or death.</p>	

For an operator to be qualified, he or she must not use drugs or alcohol which impair alertness or coordination while working. An operator who is taking prescription drugs must get medical advice to determine if he or she can safely operate a machine and the equipment.

Understand the written instructions, rules and regulations:

- The written instructions from Farm King include the Warranty Registration, Dealer Inspection Report, Operator And Parts Manual and machine signs (decals).
- Check the rules and regulations at your location. The rules may include an employer's work safety requirements. Regulations may apply to local driving requirements or use of a Slow Moving Vehicle (SMV) emblem. Regulations may identify a hazard such as a utility line.

Have Training with Actual Operation:

- Operator training must consist of a demonstration and verbal instruction. This training is given by the machine owner prior to operation.
- The new operator must start in an area without bystanders and use all the controls until he or she can operate the machine safely under all conditions of the work area. Always fasten seat belt before operating.

Know the Work Conditions:

- Clear working area of all bystanders, especially small children and all obstacles that might be hooked or snagged, causing injury or damage.
- Know the location of any overhead or underground power lines. Call local utilities and have all underground power lines marked prior to operation.
- Wear tight fitting clothing. Always wear safety glasses when doing maintenance or service.

Use Safety Rules

- Read and follow instructions in this manual and the tractor's Operators Manual before operating.
- Under no circumstances should young children be allowed to work with this equipment.
- This equipment is dangerous to children and persons unfamiliar with its operation.
- In addition to the design and configuration of equipment, hazard control and accident prevention are dependent upon the awareness, concern, prudence and proper training of personnel involved in the operation, transport, maintenance and storage of equipment.
- Check that the equipment is securely fastened to the tractor / towing vehicle.
- Make sure all the machine controls are in the NEUTRAL position before starting the machine.
- Operate the equipment only from the operator's position.
- Operate the equipment according to the Operator And Parts Manual.
- When learning to operate the equipment, do it at a slow rate in an area clear of bystanders, especially small children.
- DO NOT permit personnel to be in the work area when operating the equipment.
- The equipment must be used ONLY on approved tractors / transport vehicles.
- DO NOT modify the equipment in any way. Unauthorized modification may impair the function and / or safety and could affect the life of the equipment.
- Stop tractor engine, place all controls in neutral, set park brake, remove ignition key and wait for all moving parts to stop before servicing, adjusting, repairing, unplugging or filling.
- DO NOT make any adjustments or repairs on the equipment while the machine is running.
- Keep shields and guards in place. Replace if damaged.
- Keep hands, feet, hair and clothing away from all moving parts.

Machine Requirements And Capabilities

- Fasten seat belt securely. If equipped with a foldable Roll-Over Protective Structure (ROPS), only fasten seat belt when ROPS is up and locked. DO NOT wear seat belt if ROPS is down.
- Stop the machine and engage the parking brake. Install blocks in front of and behind the rear tires of the machine. Install blocks underneath and support the equipment securely before working under raised equipment.
- Keep bystanders clear of moving parts and the work area. Keep children away.
- Use increased caution on slopes and near banks and ditches to prevent overturn.
- Make certain that the Slow Moving Vehicle (SMV) emblem is installed so that it is visible and legible. When transporting the equipment, use the flashing warning lights (if equipped) and follow all local regulations.
- Operate this equipment with a machine equipped with an approved Roll-Over Protective Structure (ROPS). Always wear seat belt when the ROPS is up. Serious injury or death could result from falling off the machine.
- Before leaving the operator's position:
 1. Always park on a flat level surface.
 2. Place all controls in neutral.
 3. Engage the parking brake.
 4. Stop engine.
 5. Wait for all moving parts to stop.
- Carry passengers only in designated seating areas. Never allow riders on the machine or equipment. Falling off can result in serious injury or death.
- Start the equipment only when properly seated in the operator's seat. Starting a machine in gear can result in serious injury or death.
- Operate the machine and equipment from the operator's position only.
- The parking brake must be engaged before leaving the operator's seat. Roll-away can occur because the transmission may not prevent machine movement.

Transport Safety

- Do not exceed 5 mph (8 kph). Reduce speed on rough roads and surfaces.
- Comply with state and local laws governing highway safety and movement of machinery on public roads.
- The use of flashing amber lights is acceptable in most localities. However, some localities prohibit their use.
- Local laws should be checked for all highway lighting and marking requirements.
- Always yield to oncoming traffic in all situations and move to the side of the road so any following traffic may pass.
- Always enter curves or drive up or down hills at a low speed and at a gradual steering angle.
- Never allow riders on either tractor or equipment.
- Keep tractor / towing vehicle in a lower gear at all times when traveling down steep grades.
- Maintain proper brake settings at all times (if equipped).

Fire Prevention



Maintenance

- The machine and some equipment have components that are at high temperatures under normal operating conditions. The primary source of high temperatures is the engine and exhaust system. The electrical system, if damaged or incorrectly maintained, can be a source of arcs or sparks.
- Flammable debris (leaves, straw, etc.) must be removed regularly. If flammable debris is allowed to accumulate, it can cause a fire hazard. Clean often to avoid this accumulation. Flammable debris in the engine compartment is a potential fire hazard. The operator's area, engine compartment and engine cooling system must be inspected every day and cleaned if necessary to prevent fire hazards and overheating.
- All fuels, most lubricants and some coolant mixtures are flammable. Flammable fluids that are leaking or spilled onto hot surfaces or onto electrical components can cause a fire.

Operation

- The Farm King machine must be in good operating condition before use.
- Check all of the items listed on the service schedule under the 8 hour column before operation. (See Maintenance section)
- Do not use the machine where exhaust, arcs, sparks or hot components can contact flammable material, explosive dust or gases.

Starting

- Do not use ether or starting fluids on any engine that has glow plugs. These starting aids can cause explosion and injure you or bystanders.
- Use the procedure in the tractor's operator's manual for connecting the battery and for jump starting.

Electrical



- Check all electrical wiring and connections for damage. Keep the battery terminals clean and tight. Repair or replace any damaged part or wires that are loose or frayed.
- Battery gas can explode and cause serious injury. Do not jump start or charge a frozen or damaged battery. Keep any open flames or sparks away from batteries. Do not smoke in battery charging area.

Hydraulic System

- Check hydraulic tubes, hoses and fittings for damage and leakage. Never use open flame or bare skin to check for leaks. Hydraulic tubes and hoses must be properly routed and have adequate support and secure clamps. Tighten or replace any parts that show leakage.
- Always clean fluid spills. Do not use gasoline or diesel fuel for cleaning parts. Use commercial nonflammable solvents.

Fueling



- Stop the engine and let it cool before adding fuel. No smoking! Do not refuel a machine near open flames or sparks. Fill the fuel tank outdoors.

Fire Extinguishers



- Know where fire extinguishers and first aid kits are located and how to use them. Inspect the fire extinguisher and service the fire extinguisher regularly. Obey the recommendations on the instructions plate.

Equipment And Safety Signs (Decals)

Follow the instructions on all the signs (decals) that are on the equipment. Replace any damaged signs (decals) and be sure they are in the correct locations. Equipment signs are available from your Farm King equipment dealer.

Figure 3

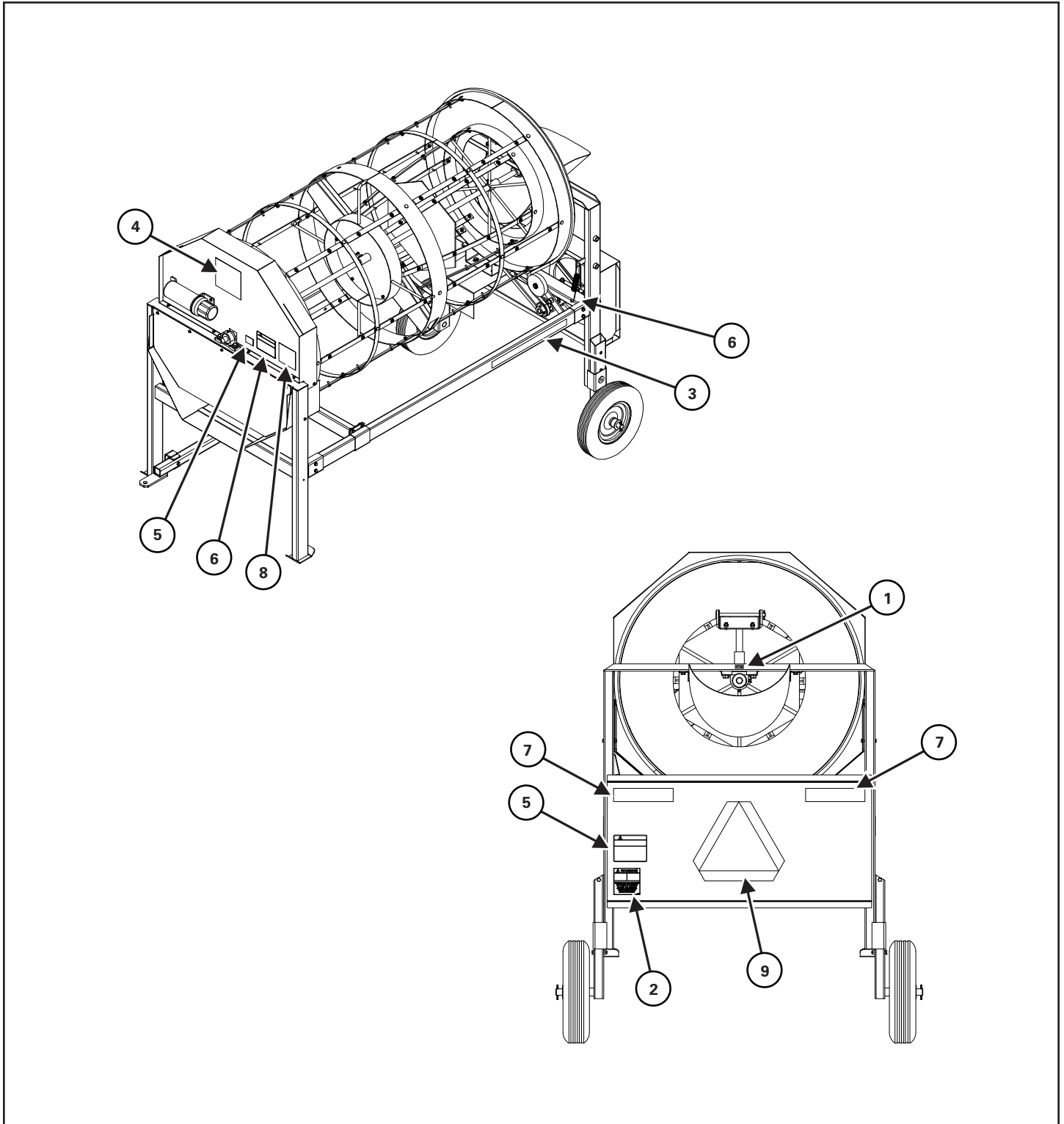

Equipment And Safety Signs [Figure 3]

SZ06057 - GREASE GUN SILHOUETTE (Item 1)

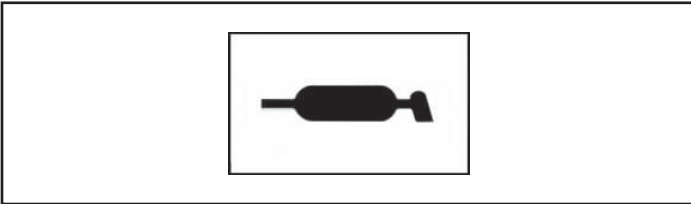

966699 - GREASE (Item 6)

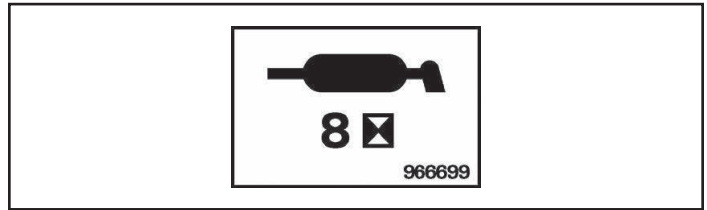

SZ06023 - WARNING, SHIELD (Item 2)



967053 - REFLECTIVE 2 X 9 RED (Item 7)



819851 - FK SIDE (Item 3)



967382 - CAUTION (Item 8)



819852 - FK REAR (Item 4)



86547711 - SMV (Item 9)

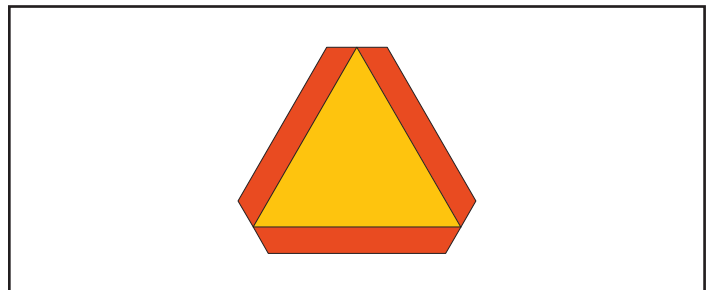

918272 - DANGER ROTATING DRIVELINE (Item 5)



Farm King



Assembly

Preparing For Assembly.....	19
Frame Assembly.....	20
Wheel Assembly.....	20
Pulley Assembly.....	22
Motor Assembly (Motor Not Supplied).....	22
Belt Routing.....	22
Front Guard Assembly.....	24
Rear Guard Assembly.....	24
Drum Assembly.....	24

Farm King



Preparing For Assembly

	IMPORTANT
<p>Equipment may be shipped without some components installed due to transport restrictions.</p> <ul style="list-style-type: none"> • Using the packing list, locate and count the individual components and verify that you have received the correct number of each component. • Check all the components for damage. If any components are damaged or missing, contact your Farm King dealer. 	

	WARNING
	
<p>AVOID INJURY OR DEATH</p> <p>Before moving the tractor, look in all directions and make sure no bystanders, especially small children are in the work area. Do not allow anyone between the tractor and the equipment when backing up to the equipment for connecting.</p>	

Move the tractor, equipment and components to an area large enough for assembly.

	WARNING
<p>AVOID INJURY OR DEATH</p> <p>Before you leave the operator's position:</p> <ul style="list-style-type: none"> • Always park on a flat level surface. • Place all controls in NEUTRAL. • Engage the park brake. • Stop the engine and remove the key. • Wait for all moving parts to stop. 	

Park the tractor / equipment on a flat level surface.

Place all controls in neutral, engage the park brake, stop the engine and wait for all moving parts to stop. Leave the operator's position.

	WARNING
<p>AVOID INJURY OR DEATH</p> <p>Wear safety glasses to prevent eye injury when any of the following conditions exist:</p> <ul style="list-style-type: none"> • When fluids are under pressure. • Flying debris or loose material is present. • Engine is running. • Tools are being used. 	

	IMPORTANT
<p>The directions front, rear, right, and left are viewed as the operator sitting in the tractor with the equipment hitched to the tractor.</p>	

Frame Assembly

Position the rear frame (Item 1) and front frame (Item 2) with two frame sides (Item 3). Attach using 5/16" x 2-1/4" hex bolts (Item 4), 5/16" flat washers, and 5/16" lock nuts **[Figure 4]**.

Position the frame cross brace (Item 5) between the frame sides. Attach using two frame clamps (Item 6) with 5/16" x 3/4" hex bolts, 5/16" flat washers, and 5/16" lock nuts **[Figure 4]**.

The hitch (Item 7) is pushed through the mount in the front frame and mount in the frame cross brace. Attach the hitch to the mounts with 3/4" x 4-1/4" clevis pins and hairpin clips **[Figure 4]**.

The hitch length is adjusted by moving the position of the frame cross brace.

	IMPORTANT
All bolts connecting the frame must be firmly tightened to proper torque. Any loose bolts could result in the frame separating while towing the cleaner.	

Position one 1" pillow bearing (Item 8) on top of the front frame. Attach using 1/2" x 1-1/2" hex bolts, 1/2" flat washers, and 1/2" lock nuts **[Figure 4]**.

Position one 1" pillow bearing (Item 9) on the underside of the rear frame as shown. Position one intake auger pivot bracket (Item 10) on the top side of the rear frame as shown. Attach pillow bearing and pivot bracket with 1/2" x 1-3/4" hex bolts, 1/2" flat washers, and 1/2" lock nuts **[Figure 4]**.

Position the intake auger swivel and connector (Item 11) in the pivot bracket (Item 10). Attach one swivel pin with cotter pin to the connector **[Figure 4]**.

Wheel Assembly

Slide the rear legs (Item 12) into the sleeves at the bottom of the rear frame. Attach legs to frame using pin and hair pin clip **[Figure 4]**.

Place wheel spacers (Item 13) on the stub shafts and mount the wheels (Item 14). Attach wheels using 1" I.D. flat washer and a 1/4" x 1-1/2" cotter pin **[Figure 4]**.

Figure 4

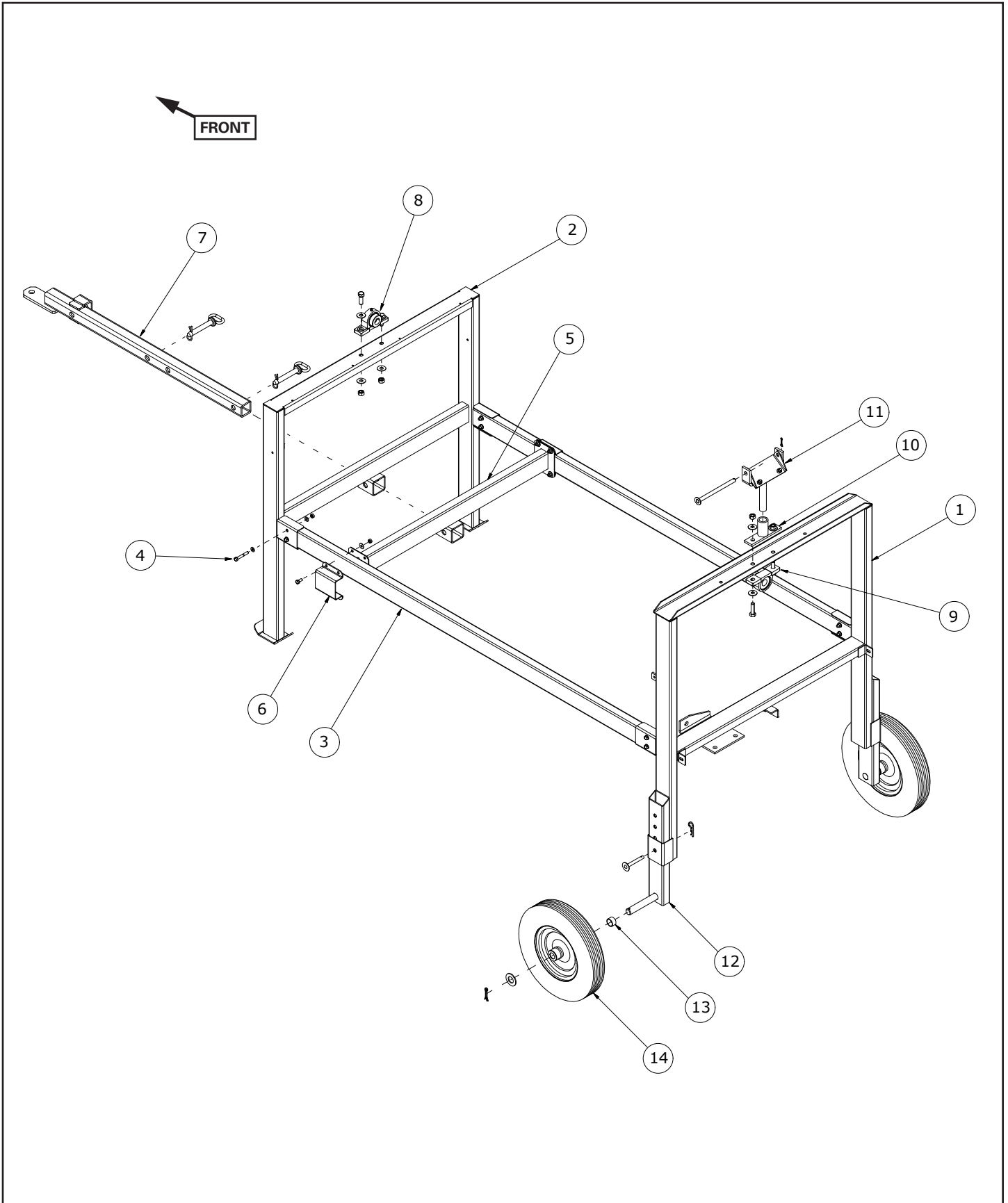

Pulley Assembly

Slide two 1" pillow bearings (Item 1) onto the reducer shaft (Item 2). Attach the two bearings to the bottom of the reducer mount (Item 3) using 1/2" x 1-3/4" hex bolts, 1/2" flat washers, and 1/2" lock nuts [Figure 6].

Position the center hole of idler arm (Item 4) on the reducer mount (Item 3). The small hole on the reducer arm should face left. Attach the idler arm to the reducer mount using one 5/8" x 1-3/4" hex bolt, 5/8" flat washers, and 5/8" lock nut [Figure 6].

Attach one idler pulley (Item 5) to the idler arm using one 5/8" x 1-3/4" hex bolt, 5/8" I.D. flat washer, and 5/8" jam nut [Figure 6].

Position one 15" pulley (Item 6) on the rear end of the reducer shaft. Attach pulley using one 1/4" Sq. x 2-1/4" key and two 5/16" x 5/8" socket set screws [Figure 6].

Position one 3" pulley (Item 7) on the front end of the reducer shaft. Attach pulley using one 3/8" x 3/8" socket set screws [Figure 6].

Position the motor mount (Item 8) on the rear frame with two motor mount clamps (Item 9). Attach motor mount and clamps using 3/8" x 1" hex bolts, 3/8" flat washers, and 3/8" lock nuts [Figure 6].

Connect the belt tightener rod between the motor mount and the welded bracket (Item 10) on the frame using one 1/2" jam nuts [Figure 6].

Motor Assembly (Motor Not Supplied)

Attach the motor guard (Item 11) and 1 H.P. electric motor (not shown) to the motor mount (Item 8) using 3/8" x 1" hex bolts, 3/8" flat washers, and 3/8" lock nuts [Figure 6].

Motor shaft must face rear. Motor guard must face front (not shown).

Position one 2-1/2" pulley on the electric motor shaft. Attach using one 3/16" sq. x 1-1/2" key and one 1/4" x 1/2" socket setscrew (not shown).

Belt Routing

Figure 5

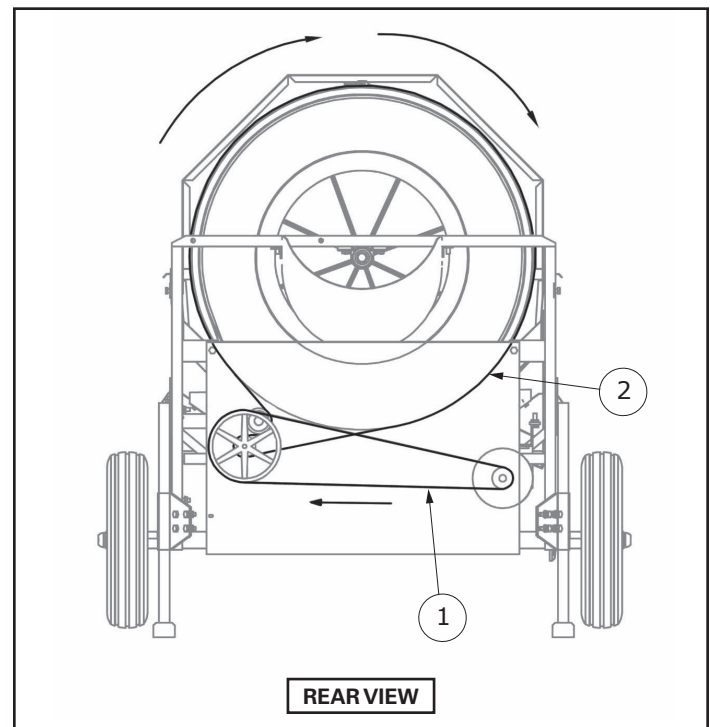

Route one B-62 V-Belt (Item 1) around the motor pulley and 15" pulley [Figure 5].

Tighten belt using belt tightener rod (Item 10) [Figure 6].

Route one B-133 V-Belt (Item 2) around the outer drum assembly, the 3" pulley, and idler pulley [Figure 5].

Tighten belt by connecting the belt tightener spring (Item 12) to the idler arm (Item 4) [Figure 6].

Figure 6

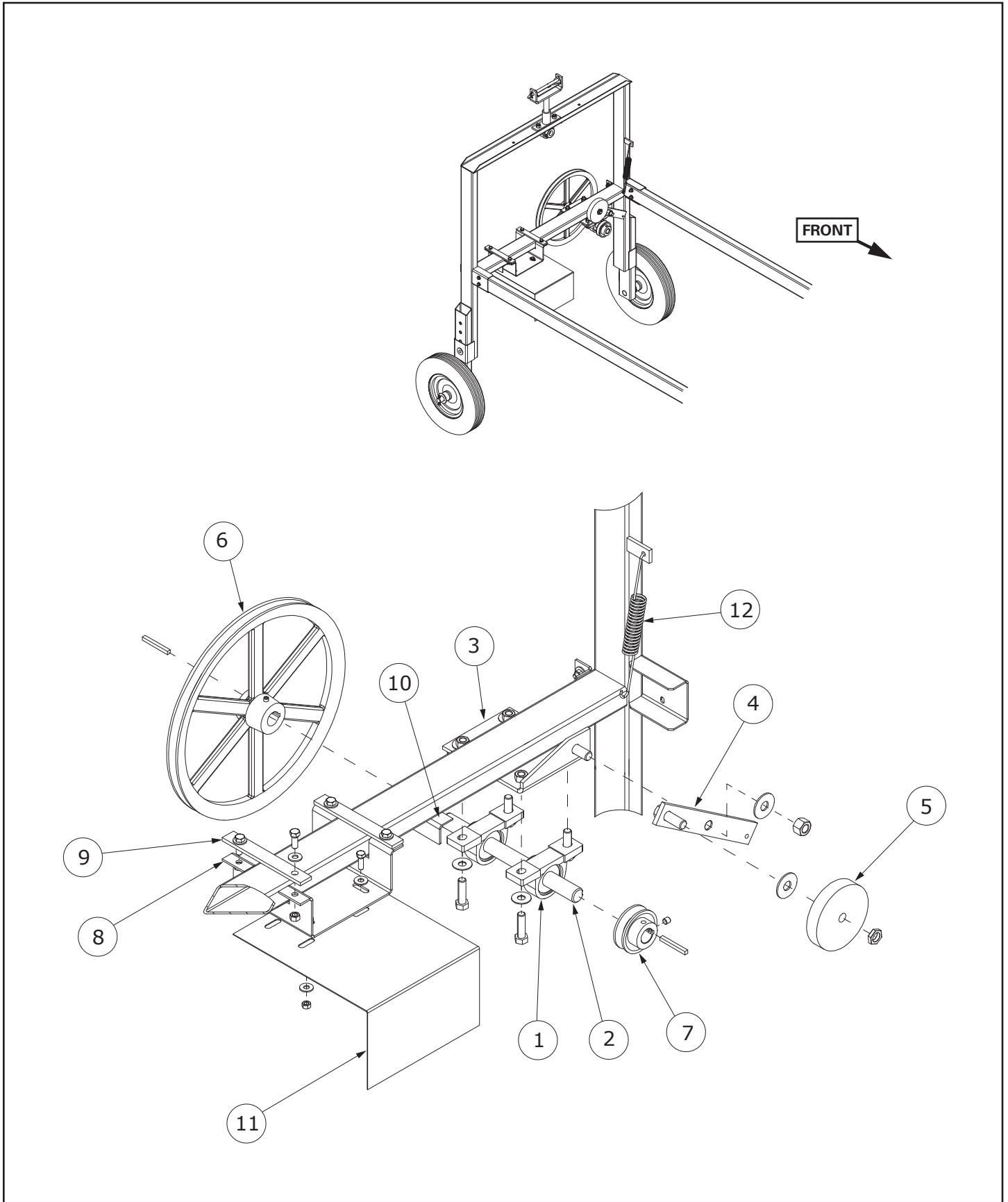

Front Guard Assembly

Position the discharge weldment (Item 1) on the front frame. Attach sides of discharge weldment to front frame using 1/4" flat washers, 1/4" lock nuts, and 1/4" x 2" hex bolts (Item 2) **[Figure 7]**.

Attach top of discharge weldment to front frame using 1/4" x 3/4" self-tap screws (Item 3) **[Figure 7]**.

Position the drum shield (Item 4) on the discharge weldment. Attach sides of drum shield to discharge weldment using 1/4" x 3/4" hex bolts, 1/4" flat washers, and 1/4" lock nuts (Item 5) **[Figure 7]**.

Attach bottom of drum shield to front frame using 1/4" x 3/4" self-tap screws (Item 6) **[Figure 7]**.

Attach the manual canister (Item 7) to the front frame using 5/16" x 3/4" hex bolts, 5/16" flat washers, and 5/16" lock nuts **[Figure 7]**.

Attach the safety chain (Item 8) to the hitch using 3/4" x 4" hex bolt, 3/4" flat washers, and 3/4" lock nut **[Figure 7]**.

Rear Guard Assembly

Position the pulley guard (Item 9) on the rear frame. Attach pulley guard using 5/16" x 3/4" hex bolts, 5/16" flat washers, and 5/16" lock nuts **[Figure 7]**.

Position the intake pan (Item 10) on the rear frame. Attach the intake pan using 3/8" x 1" hex bolts, 3/8" flat washers, and 3/8" lock nuts **[Figure 7]**.

Drum Assembly

Assemble the inner cone (Item 11), outer drum (Item 12), and center drum shaft (Item 13) **[Figure 7]**. Install assembly and center drum shaft to pillow bearings on main frame.

Assemble the inner cone screen (Item 14) and outer drum screen (Item 15). The center screen sections are notched to fit around the trash outlets **[Figure 7]**.

Attach the screen sections using 1/4" x 3/4" self-tap screws and flat washers. Strap the ends of the screen sections to the rear and center rings using the two straps.

Tighten straps with 1/4" x 2-1/2" round head bolts and 1/4" lock nuts. After strapping, the screen is tightened by attaching the remaining self-tapping screws.

All the strap bolts holding the screens should be turned so the end of the bolt trails the direction of drum rotation.

Figure 7

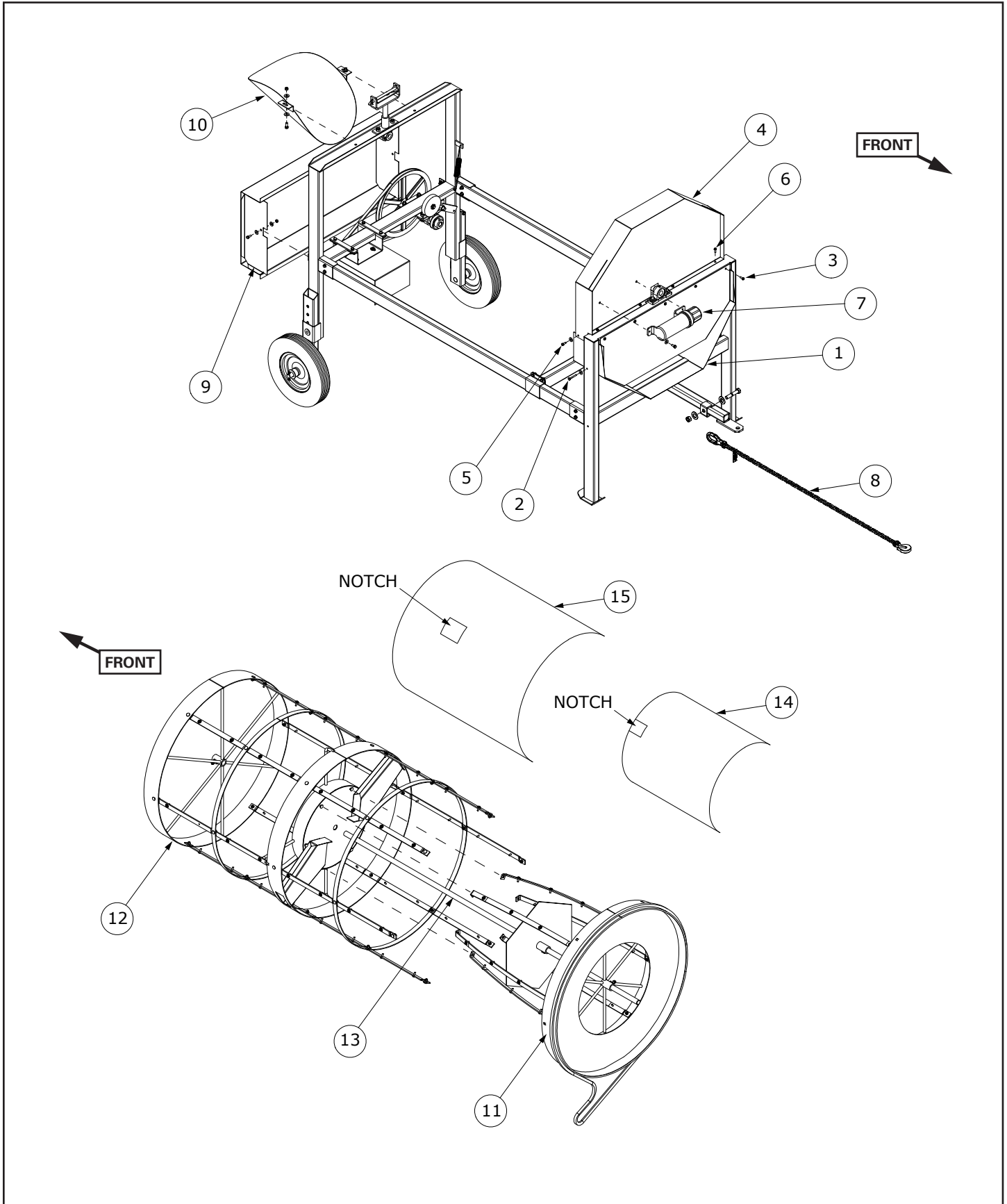

Farm King



Operation

Pre - Operation Checklist.....29

Theory Of Operation.....30

 Operation.....30

Transporting.....31

Farm King



Pre - Operation Checklist

Before operating the equipment for the first time and each time thereafter, check the following items:

1. Lubricate the equipment per the schedule outline in the Maintenance Section.
2. Check the equipment for damaged, loose or missing parts. Repair as needed before operation.
3. Use only a tractor of adequate power and weight to pull the machine.
4. Check the drums. Remove any twine, wire or other material that has become entangled.
5. Check belt tension.
6. Check that all bearings turn freely. Replace any that are rough or seized.
7. Make sure that all guards and shields are in place, secured and functioning as designed.

	WARNING
	
AVOID INJURY OR DEATH	
<p>Before moving the tractor, look in all directions and make sure no bystanders, especially small children are in the work area.</p> <p>Do not allow anyone between the tractor and the equipment when backing up to the equipment for connecting.</p>	

	WARNING
	
AVOID INJURY OR DEATH	
<p>Keep fingers and hands out of pinch points when connecting and disconnecting equipment.</p>	

	WARNING
AVOID INJURY OR DEATH	
<p>Before you leave the operator's position:</p> <ul style="list-style-type: none"> • Always park on a flat level surface. • Place all controls in NEUTRAL. • Engage the park brake. • Stop the engine and remove the key. • Wait for all moving parts to stop. 	

Theory Of Operation

The Farm King 362 Grain Cleaner handles up to 700 bushels per hour. The 362 Grain Cleaner also uses two stage screening.

Trash and fines are discharged onto the ground while cleaned grain comes out the chute for convenient loading.

	<h1>CAUTION</h1>
<ul style="list-style-type: none"> • Read operator and parts manual before operating the implement. • Do not permit riders. • Keep all guards and shields in place. • Keep hands, feet, clothing and hair away from moving parts. • Stop engine, set brake, remove key and wait for all moving parts to stop before servicing, adjusting, repairing and unplugging. • Remove bystanders, especially children, before starting or while operating. • Block up before working beneath unit. • Review safety instructions annually. 	

	<h1>WARNING</h1>
	
<h2>ROTATING DRIVELINE HAZARD</h2> <ul style="list-style-type: none"> • Keep shields and all guards in place. • Keep away from moving parts. • Keep bystanders away. 	

Operation

Connect the equipment to the tractor and place the support stands into the travel position.

Move equipment to the work area.

Adjust the height of the rear legs to maximize capacity.

Position and adjust bins or intake auger (if applicable).

Choose the appropriate screen for the work required.

The cone flow control must be set to minimize grain loss through the trash outlets.

Capacity will vary with grain type and moisture content. The flow control on the intake auger will allow you to match input to the equipment capacity (if applicable).

The equipment should run until empty before stopping. Do not leave grain in the drum or start the equipment with a load of grain in it.

Keep all shields in place while cleaner is running. Stop cleaner to make any adjustments.

Figure 8

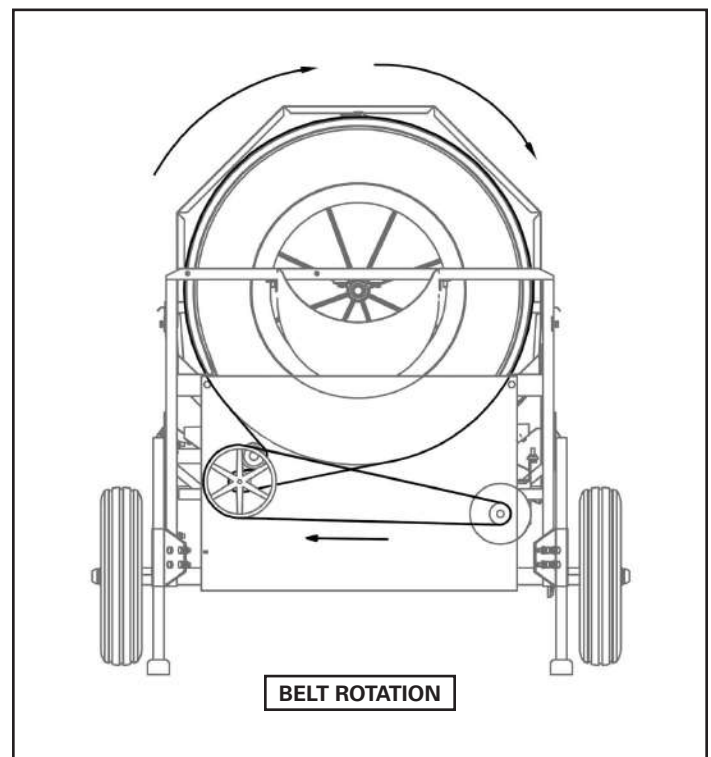

Transporting

Always comply with federal, state, local and provincial laws regarding the transport of farm equipment on public roadways.

	WARNING
AVOID INJURY OR DEATH	
<ul style="list-style-type: none"> • Keep shields and all guards in place • Keep bystanders away. • Do not allow riders. • Always use hazard flashers on the tractor when transporting unless prohibited by law. • Always follow local regulations when transporting on public roadways. Check with your local authorities. 	

	IMPORTANT
<p>Do not exceed 5 mph (8 kph).</p> <p>The grain cleaner is not meant to travel long distances.</p>	

Verify safety chain is installed and properly connected before transporting equipment.

Tires provided are for low speed towing only. Fill tires to a maximum of 32 psi (220 kPa).

Verify that the tractor / tow vehicle is approved for transporting the equipment and that the equipment is securely attached to the tractor / tow vehicle.

	WARNING
<p>Use of an unapproved hitch or tractor / tow vehicle can result in loss of control, leading to serious injury or death.</p> <p>Tractor / tow vehicle and hitch must have the rated capacity to tow equipment.</p>	

Farm King



Maintenance

Service Schedule..... 35

Lubrication..... 36

Belt Tension..... 37

Tire Pressure..... 37

Safety Sign (Decal) Installation..... 38

Storage And Return To Service..... 38

 Storage..... 38

 Return To Service..... 38

Farm King



Service Schedule

	WARNING
<p>Instructions are necessary before operating or servicing equipment. Read and understand the Operator And Parts Manual and safety signs (decals) on equipment. Follow warnings and instructions in the manuals when making repairs, adjustments or servicing. Check for correct function after adjustments, repairs or service. Untrained operators and failure to follow instructions can cause injury or death.</p>	

Maintenance work must be done at regular intervals. Failure to do so will result in excessive wear and early failures. The service schedule is a guide for correct maintenance of the equipment.

#	DESCRIPTION	SERVICE PROCEDURES					
		CHECK	CLEAN	LUBE	CHANGE	COVER	DRAIN
Daily Maintenance (or every 8 hours of use)							
1	Drum Screens	✓	✓				
2	Pulleys & Belt Tension	✓					
3	Guards & Shields	✓					
4	Tire Pressure	✓					
Weekly (or every 40 hours of use)							
4	Driveline Pillow Bearings	✓		✓			
Annually (or every 500 hours of use)							
5	Entire Machine	✓	✓				

Lubrication

Always use a good quality multi-purpose / lithium base grease when lubricating the equipment.

!	IMPORTANT
<p>Do not over-grease bearings. Greasing too often can damage seals and lead to premature bearing failure.</p>	

- Always use a hand-held grease gun.
- Clean fitting before greasing, to avoid injecting dirt and grit.
- Replace and repair broken fittings immediately.
- If fittings will not take grease, remove and clean thoroughly. Replace fitting if necessary.

!	IMPORTANT
<p>Fluid such as engine oil, hydraulic fluid, coolants, grease, etc. must be disposed of in an environmentally safe manner. Some regulations require that certain spills and leaks on the ground must be cleaned in a specific manner. See local, state and federal regulations for the correct disposal.</p>	

!	WARNING
<p>AVOID INJURY OR DEATH</p>	
<p>Stop engine, set brake, remove ignition key, and wait for all moving parts to stop before servicing, adjusting, repairing, or unplugging.</p>	
<p>Support the equipment with blocks or safety stands before working beneath it.</p>	
<p>Follow good shop practices:</p> <ul style="list-style-type: none"> • Keep service area clean and dry • Be sure electrical outlets and tools are properly grounded • Use adequate light for the job. 	
<p>Use only tools, jacks, and hoists of sufficient capacity for the job.</p>	
<p>Replace and secure all shields removed during servicing before operating.</p>	
<p>Use heavy leather gloves to handle sharp objects.</p>	

Figure 9

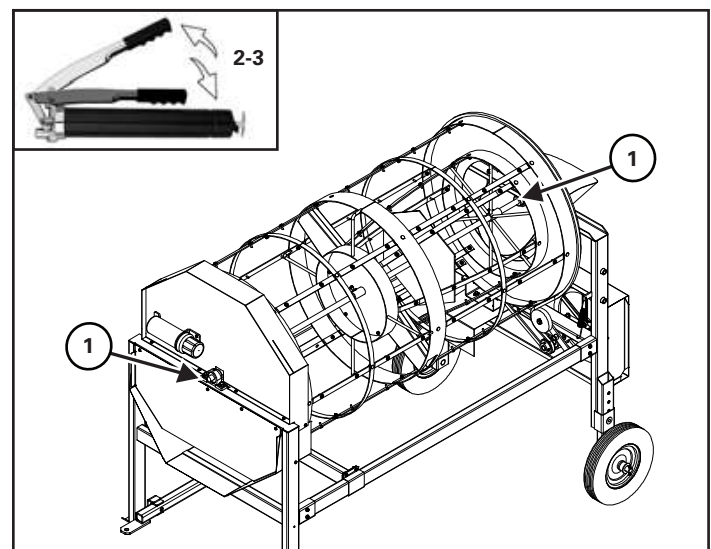

Apply two to three pumps of grease (Item 1) to the driveline pillow bearings [Figure 9].

Grease every **40 hours** of use.

Belt Tension

Figure 10

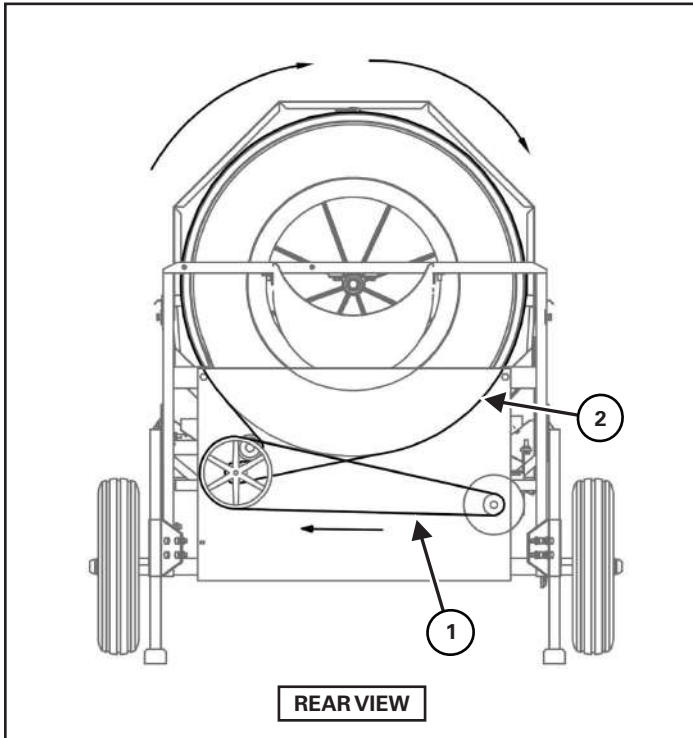

Check tension of belts:

- B-62 V-Belt (Item 1) around the motor pulley and 15" pulley. Tighten belt using belt tightener rod connected to motor mount [Figure 10].
- B-133 V-Belt (Item 2) around the outer drum assembly, the 3" pulley, and idler pulley. Tighten belt using tightener spring connected to idler arm [Figure 10].

Check every **8 hours** of use.

Tire Pressure

Figure 11

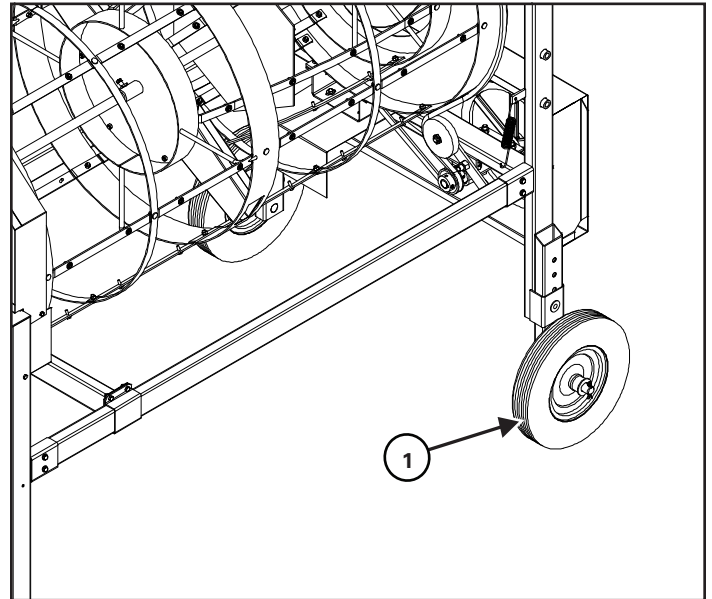

Fill tires (Item 1) to a maximum of 32 psi (220 kPa) [Figure 11].

Check every **8 hours** of use.

Safety Sign (Decal) Installation



- Remove all portions of the damaged safety sign (decal).
- Thoroughly clean the area with adhesive remover and glass cleaner. Remove all adhesive residue.
- Allow the area to dry completely before installing the new safety sign (decal).
- Position the safety sign (decal) in the correct location.
- Remove a small portion of the backing paper on the safety sign (decal).
- Press on the safety sign (decal) where the backing paper has been removed.
- Slowly remove the remaining backing paper, pressing on the safety sign (decal) as the backing paper is removed.
- Using the backing paper, pressing firmly, move the backing paper over the entire safety sign (decal) area.

Note: Small air pockets can be pierced with a pin and smoothed out using the piece of the backing paper.

Storage And Return To Service

Storage

Sometimes it may be necessary to store the equipment for an extended period of time. Below is a list of items to perform before storage.



- Thoroughly clean the equipment.
- Lubricate the equipment.
- Inspect the hitch and all welds on the equipment for wear and damage.
- Check for loose hardware, missing guards, or damaged parts.
- Check for damaged or missing safety signs (decals). Replace if necessary.
- Replace worn or damaged parts.
- Touch up all paint nicks and scratches to prevent rusting.
- Place the equipment in a dry protected shelter.

Note: If a dry protected shelter is not available, cover with a waterproof tarp and tie down securely.

- Place the equipment flat on the ground.
- Support the jack / frame with planks if required.

Return To Service

After the equipment has been in storage, it is necessary to follow a list of items to return the equipment to service.

- Be sure all shields and guards are in place.
- Lubricate the equipment.
- Operate equipment, verify all functions operate correctly. Repair as needed.

Parts Identification

General Parts Information.....	40
Hitch.....	40
Wheels.....	41
Frame.....	42
Guards.....	44
Pulleys.....	46
Drum And Screen.....	48
Utility Auger.....	50
Utility Auger Mount.....	52

General Parts Information

The parts identification section list descriptions, part numbers and quantities for all North America Base Model 362 Grain Cleaners. Contact your Farm King dealer for additional parts information.

Hitch

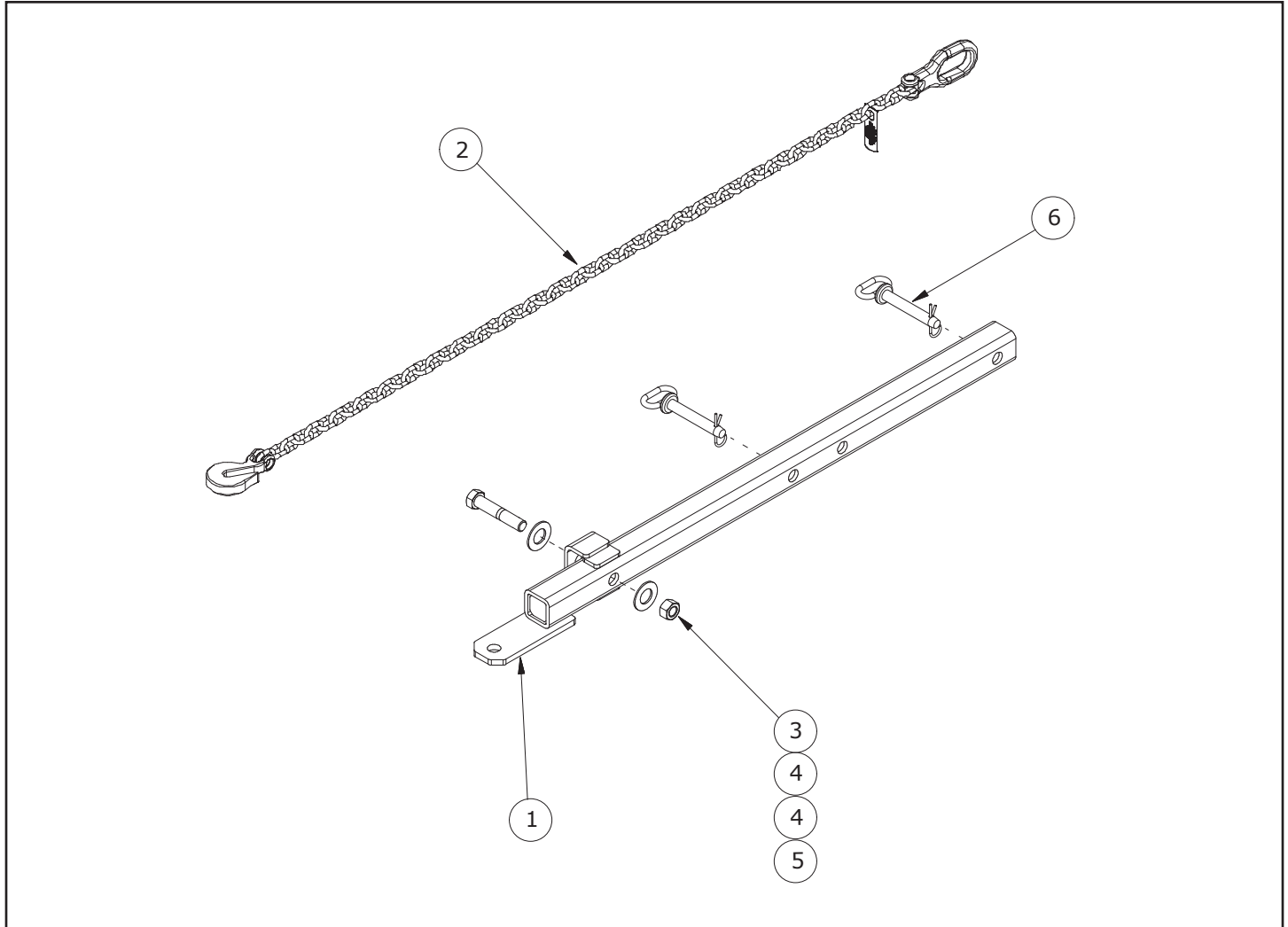

ITEM	PART NUMBER	DESCRIPTION	QTY.
1	819412	WELDMENT - HITCH	1
2	910287	HOOK & SAFETY CHAIN ASSEMBLY	1
3	84336	3/4" X 4" HEX BOLT (PL)	1
4	84050	3/4" S.A.E. FLAT WASHER (PL)	2
5	812365	3/4" LOCK NUT (PL)	1
6	816131	3/4" DIA. X 4.25" LG CLEV PIN W/ CLIP	2

Wheels

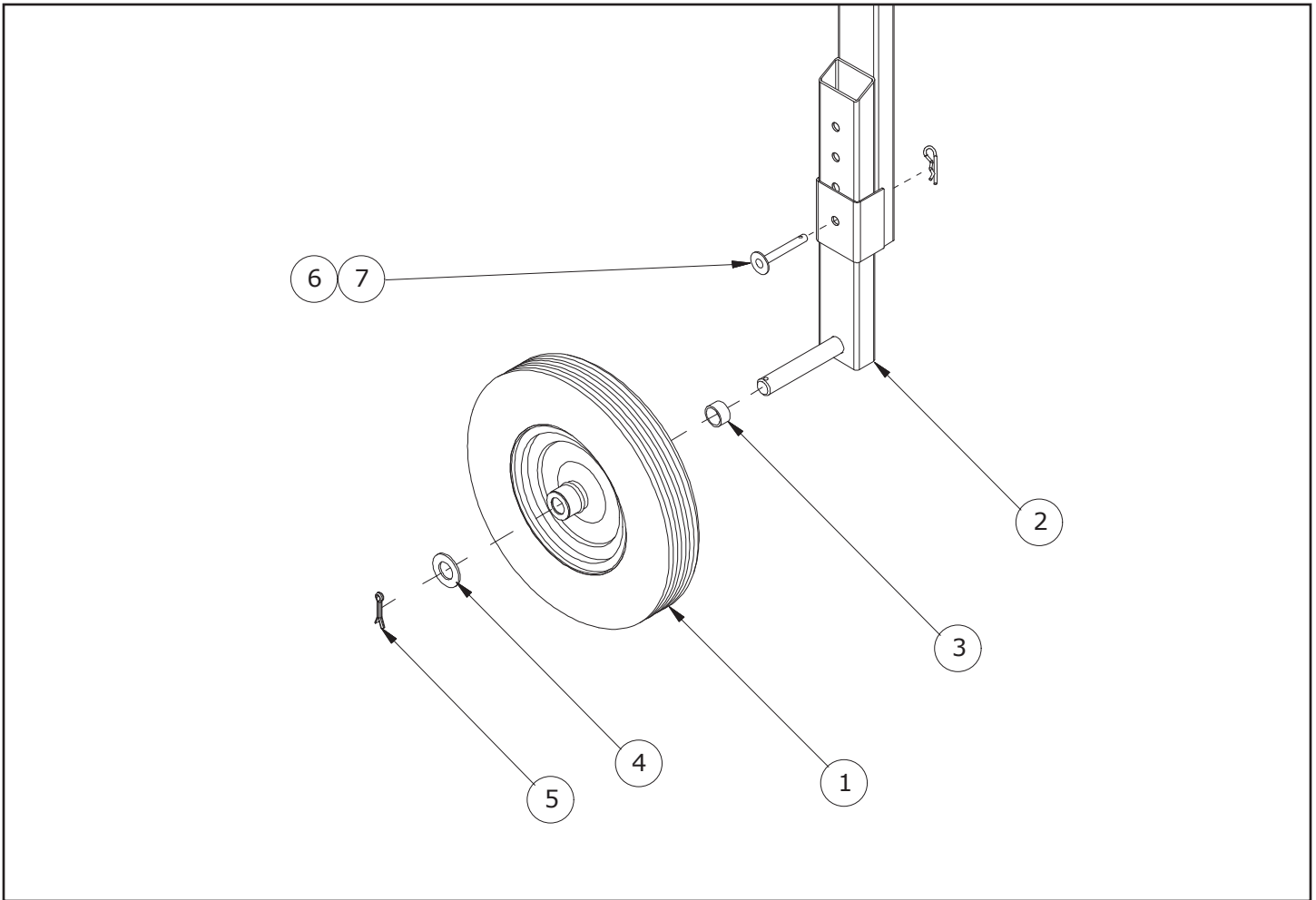

ITEM	PART NUMBER	DESCRIPTION	QTY.
1	973613	16" X 4.8" WHEEL W/TIRE	2
2	819654	WELDMENT - LEG	2
3	966811	SHEAVE SPACER Ø1.25"OD X 0.7"	2
4	84522	1" ID SAE FLATWASHER (PL)	2
5	9812434	1/4" X 1 1/2" COTTER PIN (PL)	2
6	973214	FRONT LEG PIN WELDMENT	2
7	961012	#16 HAIR PIN CLIP	2

Frame

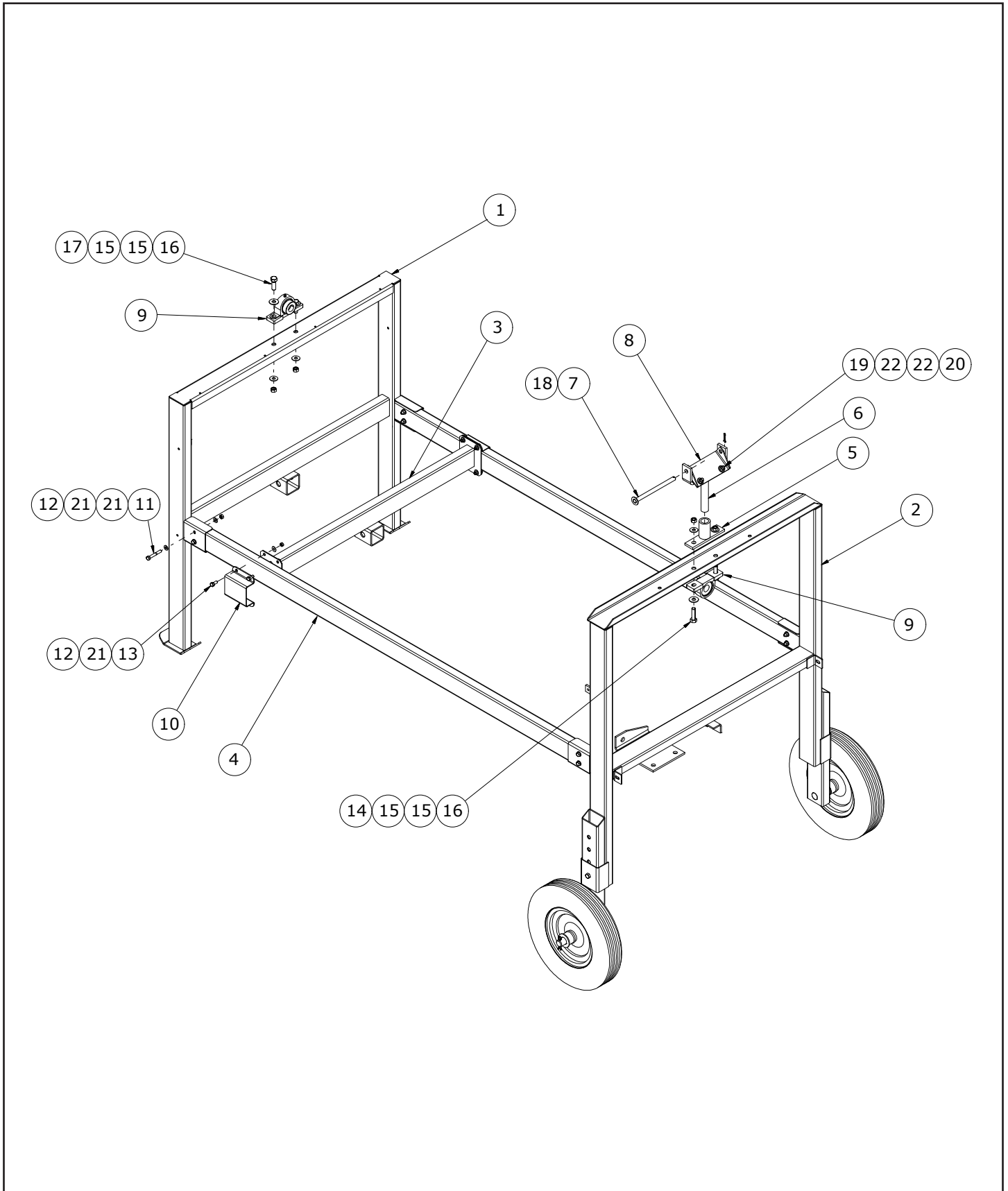

ITEM	PART NUMBER	DESCRIPTION	QTY.
1	820687	WELDMENT - FRONT FRAME	1
2	820688	WELDMENT - REAR FRAME	1
3	819404	WELDMENT - FRAME CROSS BRACE	1
4	973603	FRAME SIDE 0.100"W X 1 1/2" X 3" X 76 1/2" 2	2
5	973626	INTAKE AUGER PIVOT WELDT	1
6	973627	INTAKE AUGER SWIVEL WELDT	1
7	902996	INTAKE AUGER SWIVEL PIN	1
8	973629	INTAKE AUGER CONNECTOR PLATE	1
9	961792	HOUSING W/BEARING PILLOW (P205)	2
10	973605	FRAME CLAMP - 4 BEVEL	2
11	811688	5/16" X 2-1/4" HEX BOLT UNC GR5 (PL)	8
12	812362	5/16" LOCK NUT (PL)	16
13	81549	5/16" X 3/4" HEX BOLT (PL)	8
14	87553	1/2" X 1.75" HEX BOLT UNC GR5 (PL)	2
15	981616	WASHER-1/2" STD FLAT PL	8
16	812364	1/2" LOCK NUT (PL)	4
17	84277	1/2" X 1 1/2" HEX BOLT (PL) 2	2
18	9812430	1/8" X 1" COTTER PIN (PL)	1
19	812363	3/8" LOCK NUT (PL)	2
20	86170	3/8" X 1" HEX BOLT (PL)	2
21	812623	WASHER - 5/16" STD FLAT (PL)	24
22	81570	WASHER - 3/8" STD FLAT (PL)	4

Guards

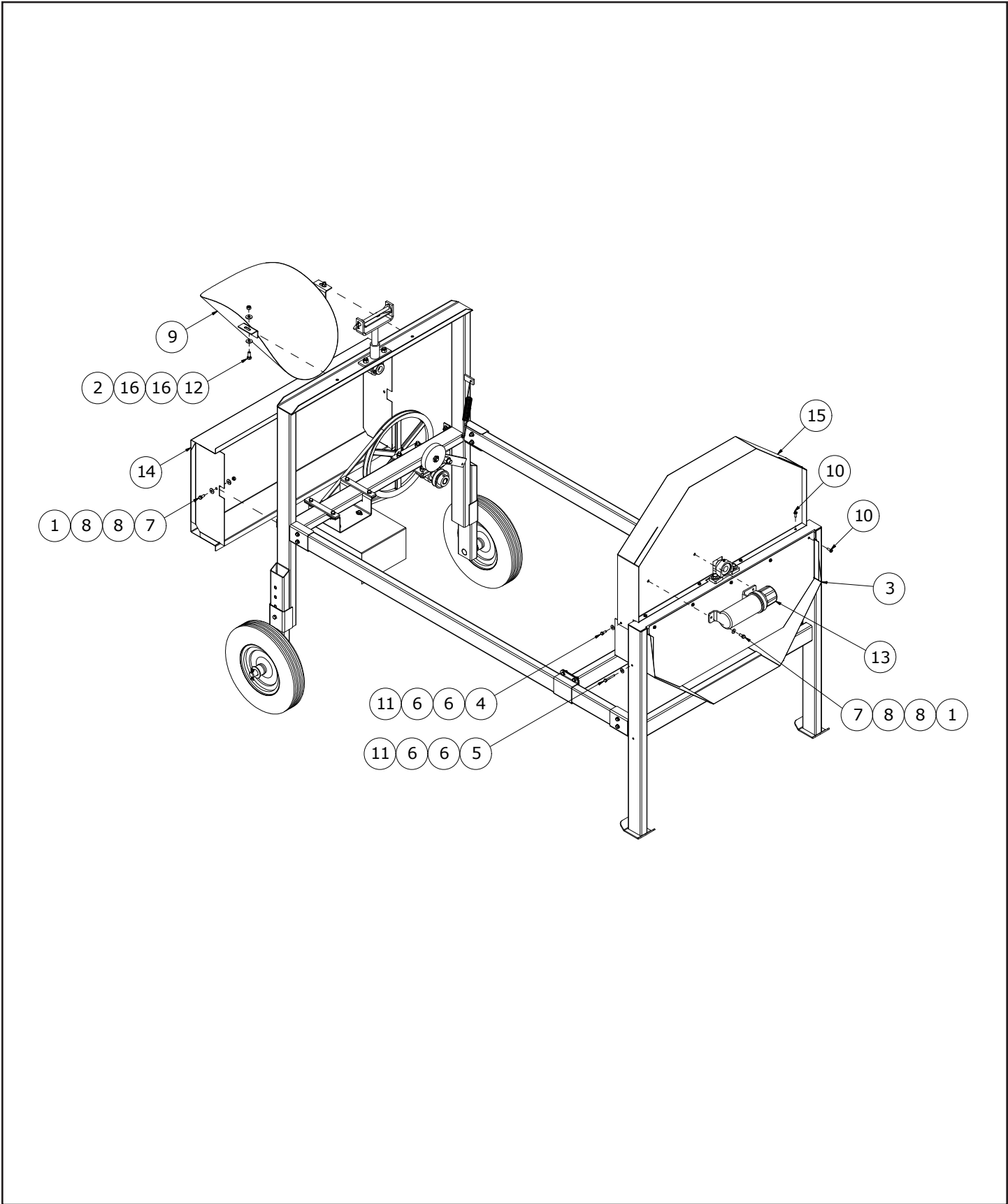

ITEM	PART NUMBER	DESCRIPTION	QTY.
1	812362	5/16" LOCK NUT (PL)	4
2	812363	3/8" LOCK NUT (PL)	2
3	F4305	DISCHARGE PAN WELDT	1
4	81525	1/4" X 3/4" HEX BOLT (PL)	4
5	81531	BOLT HEX 0.25NC X 2.00 GR5 PL	2
6	812624	1/4" FLAT WASHER (PL)	12
7	81549	5/16" X 3/4" HEX BOLT (PL)	4
8	812623	WASHER - 5/16" SAE FLAT (PL)	8
9	F4304	INTAKE PAN WELDT	1
10	9812392	SCREW SELFTAP 0.25UNC X 0.75(F)	9
11	84498	1/4" LOCK NUT (PL)	6
12	86170	3/8" X 1" HEX BOLT GR.5 (PL)	2
13	909277	MANUAL HOLDER 3 1/2" X 12"	1
14	F4306	PULLEY GUARD WELDT	1
15	F4307	REAR DRUM SHIELD WELDT	1
16	81570	WASHER FLAT STD 0.375 HS PL	4

Pulleys

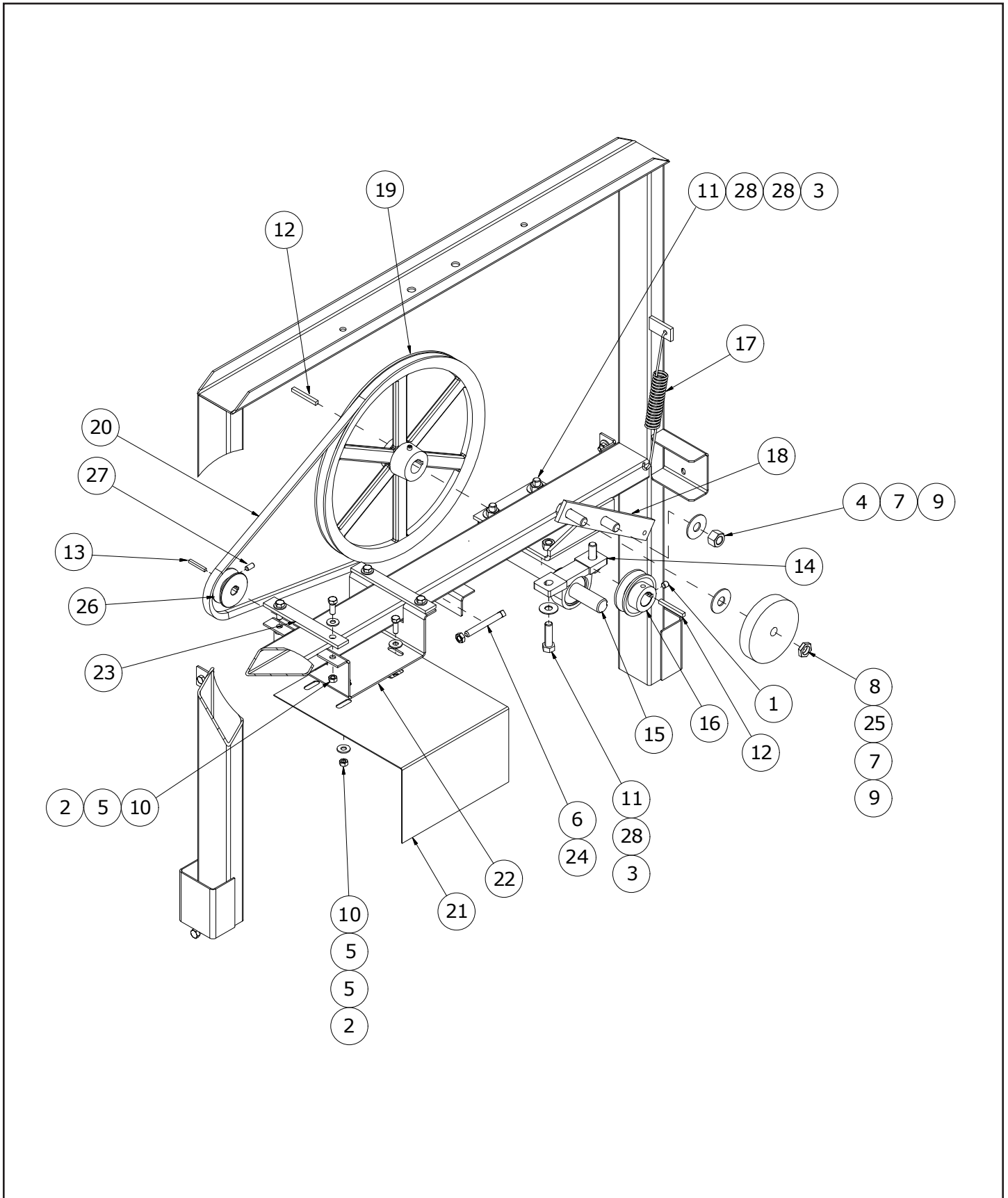

ITEM	PART NUMBER	DESCRIPTION	QTY.
1	988999	3/8"Ø X 3/8" SOCKET SET SCREW (BR)	1
2	812363	3/8" LOCK NUT (PL)	8
3	812364	1/2" LOCK NUT (PL)	4
4	812482	5/8" LOCK NUT (PL)	1
5	81570	WASHER - 3/8" STD FLAT (PL)	12
6	9812380	1/2" X 4" SQ. HD. SET SCREW (PL)	1
7	81678	5/8" FLAT WASHER STD (PL)	2
8	84126	NUT HEX JAM 0.625UNC GR 2 PL	1
9	84270	5/8" X 1 3/4" HEX BOLT (PL)	2
10	86170	3/8" X 1" HEX BOLT GR.5 (PL)	8
11	87553	1/2" X 1.75" HEX BOLT UNC GR5 (PL)	4
12	900197	1/4" SQ. X 2-1/4" KEY	2
13	900198	3/16" SQ. X 1-1/2" KEY	1
14	961792	HOUSING W/BEARING PILLOW (P205)	2
15	973615	REDUCER SHAFT 1" DIA X 11 1/2"	1
16	973616	3" SINGLE SHEAVE	1
17	973618	BELT TIGHTENER SPRING	1
18	973619	REDUCER SPRING ARM	1
19	973620	15" SINGLE PULLEY	1
20	973621	BELT B62	1
21	973622	MOTOR MOUNT GUARD	1
22	820160	MOTOR MOUNT	1
23	973624	MOTOR MOUNT CLAMPS	2
24	984077	1/2" JAM NUT (PL)	1
25	973645	IDLER PULLEY	1
26	973646	SHEAVE B2.5 1 GROOVE 5/8" BORE	1
27	819415	1/4"Ø X 1/2" SOCKET SET SCREW (BR)	1
28	981616	WASHER-1/2" STD FLAT PL	6

Drum And Screen

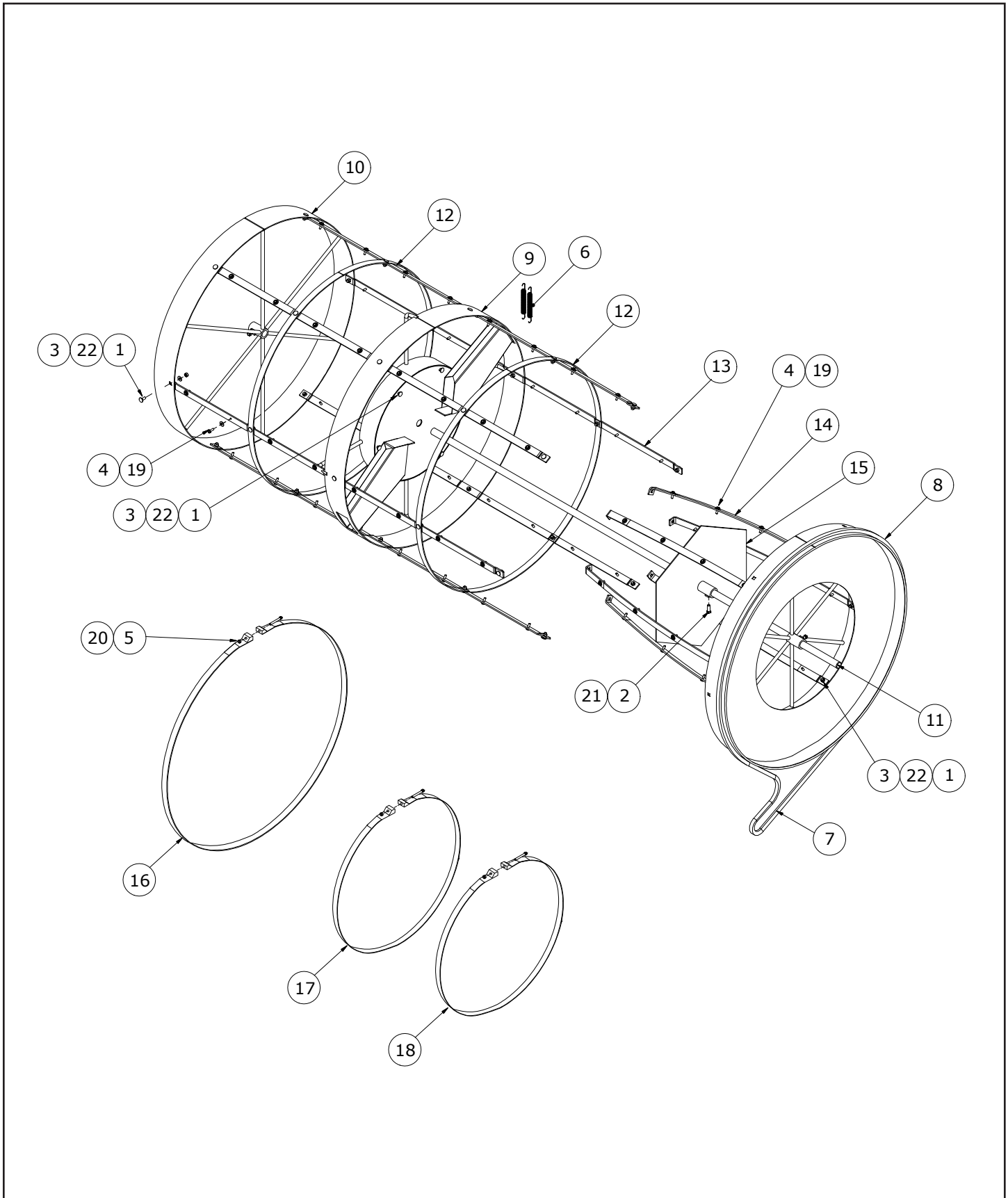

ITEM	PART NUMBER	DESCRIPTION	QTY.
1	81185	5/16" X 3/4" CARRIAGE BOLT (PL)	42
2	81213	SETSCREW SQHDCUP 0.375NC X 1 PL	4
3	812362	5/16" LOCK NUT (PL)	42
4	81546	5/16" FLAT WASHER (PL)	72
5	84498	1/4" LOCK NUT (PL)	8
6	973289	SPRING, SCREEN (GRAIN CLEANER)	2
7	973617	B-133 V-BELT	1
8	973632	FRONT DRUM RING WELDT	1
9	973633	CENTER DRUM RING WELDT	1
10	973634	BACK DRUM RING WELDT	1
11	973635	DRUM SHAFT 01" X 82"	1
12	973636	OUTER DRUM SCREEN SUPPORT	2
13	973637	DRUM SCREEN SUPPORT	6
14	973638	CONE SCREEN SUPPORT	6
15	973641	CONE FEED CONTROL WELDT	1
16	973642	DRUM STRAP 110.75" 360GC	6
17	973643	CONE STRAP 73" 360GC	1
18	973644	CONE STRAP 54" 360GC	1
19	9812392	SCREW SELFTAP 0.25UNC X 0.75(F)	72
20	9812398	BOLT STOVE 0.25 UNC X 2.50 RDHD	8
21	81592	3/8" HEX NUT (PL)	4
22	812623	WASHER - 5/16" SAE FLAT (PL)	42

-	903519	5 X 5 CONE SCREEN	3
-	973649	4 X 4 CONE SCREEN	3
-	973648	3 X 3 CONE SCREEN	3
-	924042	2 X 2 CONE SCREEN	3
-	973650	5/8 X 5/8 CONE SCREEN	3

-	911909	10 X 10 DRUM SCREEN	2
-	911906	8 X 8 DRUM SCREEN	2
-	911907	6 X 6 DRUM SCREEN	2
-	911908	5 X 5 DRUM SCREEN	2
-	911905	4 X 4 DRUM SCREEN	2

ITEM	PART NUMBER	DESCRIPTION	QTY.
1	963617	TUBE 6" X 10' - UTILITY AUGER	1
	963618	TUBE 6" X 15' - UTILITY AUGER	1
	963619	TUBE 6" X 20' - UTILITY AUGER	1
2	963604	FLIGHTING 6" X 11' - UTILITY AUGER	1
	963605	FLIGHTING 6" X 16' - UTILITY AUGER	1
	963606	FLIGHTING 6" X 21' - UTILITY AUGER	1
3	961627	BEARING W/COLLAR (AEL205-100) 1"	1
4	963009	FLANGE BEARING (52MST)	2
5	963020	SHEAVE B8 1 GROOVE 1"BORE	1
7	902967	SPOUT - UTILITY AUGER	1
8	902968	SPOUT CLAMP - UTILITY AUGER	2
9	81636	NUT HEX 0.500NC GR2PL	1
10	963021	MOTOR MOUNT 5 & 6" - UTILITY AUGER	1
11	963621	GUARD INTAKE L/CLAMP 6" - UTILITY AUGER	1
12	963622	CLAMP INTAKE GUARD 6" - UTILITY AUGER	1
13	963623	CLAMP FEED CONTROL 6" - UTILITY AUGER	1
14	963145	CONTROL LOCK WELDT - UTILITY AUGER	1
15	963624	SLIDE FEED CONTROL 6" - UTILITY AUGER	1
16	902996	INTAKE AUGER SWIVEL PIN	1
17	963025	GUARD BELT 5" & 6" - UTILITY AUGER	1
18	963030	SETSCREW SQHDCUP .500NC X 3.00PL	1
19	963026	KEY .25X1.5"	1
20	981616	WASHER FLAT STD 0.500 HS PL	1
21	81615	WASHER LOCK 0.438 PL	1
22	81614	NUT HEX 0.438NC GR2 PL	1
23	81523	BOLT HEX 0.250NC X 0.50GR5 PL	4
24	81525	BOLT HEX 0.250NC X 0.75GR5PL	2
25	81545	WASHER LOCK 0.250 PL	4
26	81544	NUT HEX 0.250NC GR2PL	6
27	81553	BOLT HEX 0.313NC X 1.50GR5 PL	1
28	81549	BOLT HEX 0.313NC X 0.75GR5PL	2
29	81568	NUT HEX 0.313NC GR2 PL	5
30	81569	WASHER 0.313 LOCK PL	5
31	81638	WASHER FLAT STD 0.563 HS PL	1
32	9812430	COTTER PIN 0.125 X 1.00 PL	1
33	81552	BOLT HEX 0.313NC X 1.25GR5PL	4
34	963098	GUARD BELT BACK PLATE RIGHT - UTILITY AUGER	1
35	963099	GUARD BELT BACK PLATE LEFT - UTILITY AUGER	1

Utility Auger Mount

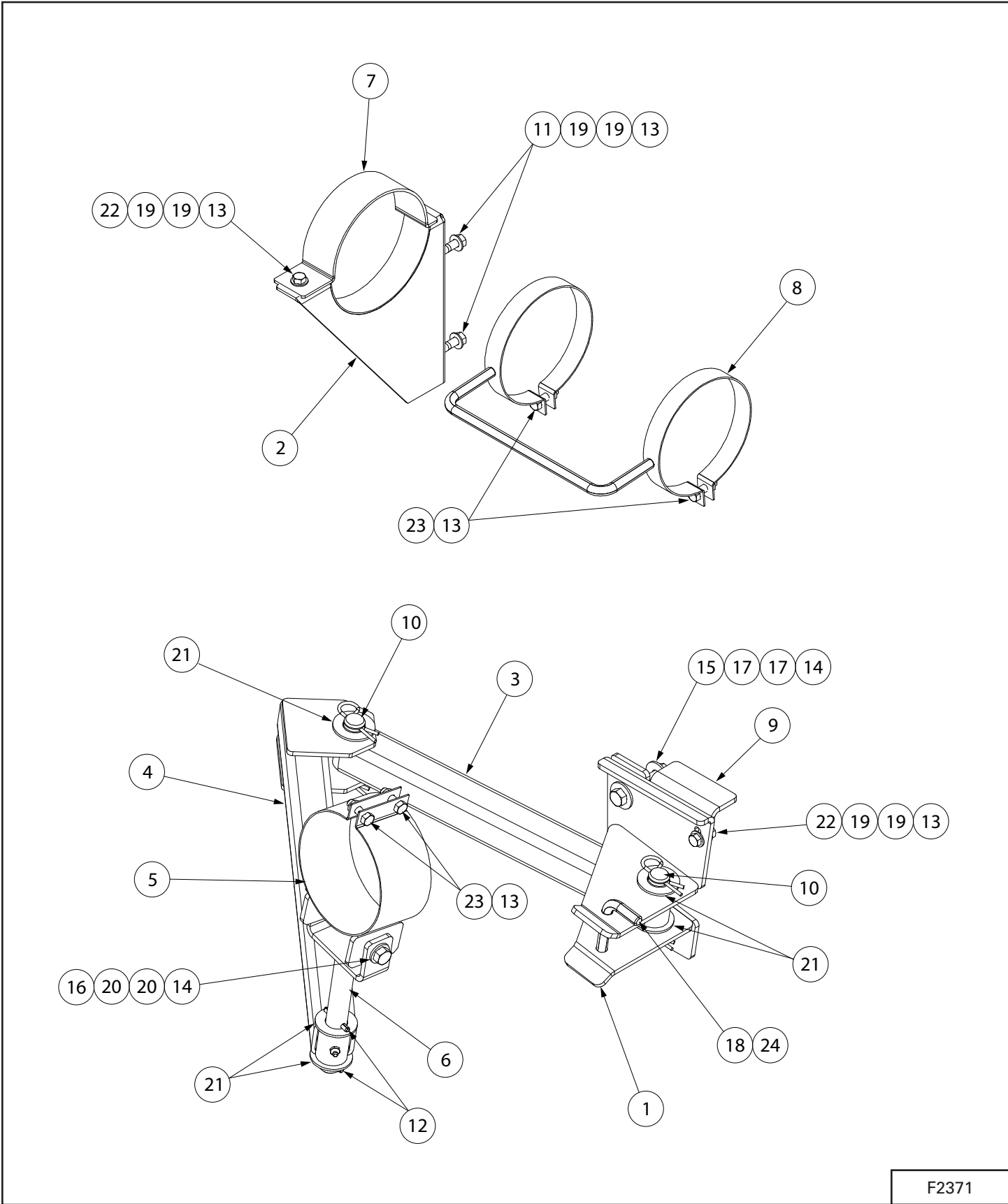

F2371

ITEM	PART NUMBER	DESCRIPTION	QTY.
1	819670	WELDMENT - AUGER PIVOT MOUNT	1
2	819340	WELDMENT - AUGER SUPPORT	1
3	819590	WELDMENT - AUGER MOUNT	1
4	819595	WELDMENT - AUGER TOP PIVOT	1
5	819597	WELDMENT - TUBE CLAMP	1
6	819603	WELDMENT - MOUNT PIVOT	1
7	819616	PLATE - HALF CLAMP	1
8	819680	WELDMENT - AUGER HANDLE	1
9	819775	WELDMENT - AUGER GUSSET	1
10	103753	CLEVIS PIN 1"Ø X 4"	2
11	810958	3/8" X 2 1/4" HEX BOLT (PL)	2
12	9812426	1/4" X 1 3/4" ROLL PIN (PL)	2
13	812363	3/8" LOCK NUT (PL)	8
14	812364	1/2" LOCK NUT (PL)	3
15	81627	1/2" X 3" HEX BOLT (PL)	2
16	81634	1/2" X 5 1/2" HEX BOLT (PL)	1
17	81638	1/2" BS FLAT WASHER (PL)	4
18	819614	BAR - AUGER TRANSPORT PIN	1
19	84039	WASHER - 3/8" SAE FLAT (PL)	8
20	84048	1/2" SAE FLAT WASHER (PL)	2
21	84522	1" ID SAE FLAT WASHER (PL)	5
22	86170	3/8" X 1" HEX BOLT GR.5 (PL)	2
23	86171	3/8" X 1 1/4" HEX BOLT (PL)	4
24	961012	#16 HAIR PIN CLIP	1

Farm King



Specifications And Shipping Kit Numbers

Specifications.....	57
Shipping Kit And Bundle Numbers.....	57
Hardware Torque Values.....	58
Metric Chart.....	58
Imperial Chart.....	59

Farm King



Specifications

Model	GC362
Height	74.0" (1879.3 mm)
Width	55.5" (1409.7 mm)
Length	112.5" (2857.5 mm)
Motor	1 HP
Drive	Belt
Capacity	700 bu/hr
Weight	493 lb
Intake Auger	6"

Note: Dimensions are approximate measurements.

Shipping Kit And Bundle Numbers

The following is a list of Kit Numbers for this product and the Bundle Numbers, Descriptions, and Quantities for each Kit.

Qty.	Bundle	Description
GC362 GRAIN CLEANER W/ HITCH, TIRES, TILT ADJ.		
1	Y362	362 GRAIN CLEANER
OPTIONAL EQUIPMENT		
1	Y621S	6" X 21' UTILITY AUGER W/FLOW CONTROL AND BOLT-ON SPOUT
1	Y616S	6" X 16' UTILITY AUGER W/FLOW CONTROL AND BOLT-ON SPOUT
1	Y611S	6" X 11' UTILITY AUGER W/FLOW CONTROL AND BOLT-ON SPOUT
1	F210	STANDARD FLEX HOPPER
1	F2371	362 GC AUGER MOUNT
SCREEN KITS		
1	F4317	10 x 10 DRUM SCREEN (2)
1	F4314	8 x 8 DRUM SCREEN (2)
1	F4315	6 x 6 DRUM SCREEN (2)
1	F4316	5 x 5 DRUM SCREEN (2)
1	F4313	4 x 4 DRUM SCREEN (2)
1	F4318	5 x 5 CONE SCREEN (3)
1	F4311	4 x 4 CONE SCREEN (3)
1	F4312	3 x 3 CONE SCREEN (3)
1	F4309	2 x 2 CONE SCREEN (3)
1	F4310	5/8 x 5/8 CONE SCREEN (3)

Hardware Torque Values

Metric Chart

NOTE: Do not use the values listed in the charts if a different torque value or tightening procedure is specified in this manual for a specific application. Torque values listed are for general use only.

Use the following charts to determine the correct torque when checking, adjusting or replacing hardware. **Torque values are listed in newton-meters (inch* or foot pounds) for normal assembly applications.**

Nominal Size	Class 5.8		Class 8.8		Class 10.9		Lock nuts
	Unplated	Plated W / ZnCr	Unplated	Plated W / ZnCr	Unplated	Plated W / ZnCr	CL.8 W/ CL. 8.8 Bolt
M4	1.7 (15*)	2.2 (19*)	2.6 (23*)	3.4 (30*)	3.7 (33*)	4.8 (42*)	1.8 (16*)
M6	5.8 (51*)	7.6 (67*)	8.9 (79*)	12 (102*)	13 (115*)	17 (150*)	6.3 (56*)
M8	14 (124*)	18 (159*)	22 (195*)	28 (248*)	31 (274*)	40 (354*)	15 (133*)
M10	28 (21)	36 (27)	43 (32)	56 (41)	61 (45)	79 (58)	30 (22)
M12	49 (36)	63 (46)	75 (55)	97 (72)	107 (79)	138 (102)	53 (39)
M16	121 (89)	158 (117)	186 (137)	240 (177)	266 (196)	344 (254)	131 (97)
M20	237 (175)	307 (226)	375 (277)	485 (358)	519 (383)	671 (495)	265 (195)
M24	411 (303)	531 (392)	648 (478)	839 (619)	897 (662)	1160 (855)	458 (338)

NOTE: Torque values shown with * are inch pounds.

Identification of Hex Cap Screws and Carriage Bolts - Classes 5 and up

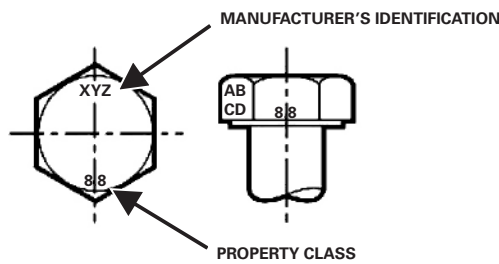

Identification of Hex Nuts and Lock Nuts - Classes 5 and up

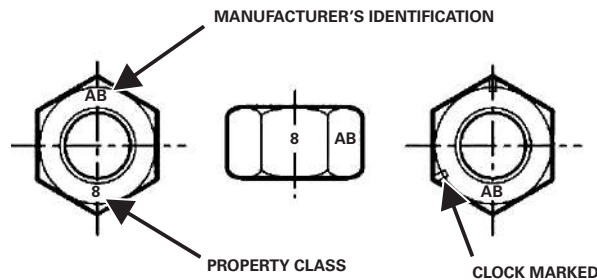

Hardware Torque Values (Cont'd)

Imperial Chart

NOTE: Do not use the values listed in the charts if a different torque value or tightening procedure is specified in this manual for a specific application. Torque values listed are for general use only.

Use the following charts to determine the correct torque when checking, adjusting or replacing hardware. Torque values are listed in newton-meters (inch* or foot pounds) for normal assembly applications.

Nominal Size	SAE Grade 5		SAE Grade 8		LOCK NUTS			
	Unplated or Plated Silver	Plated W / ZnCr Gold"	Unplated or Plated Silver	Plated W / ZnCr Gold"	Unplated or Plated Silver	Plated W / ZnCr Gold"	Grade W / Gr. 5 Bolt	Grade W / Gr. 8 Bolt
1/4	6.2 (55*)	8.1 (72*)	9.7 (86*)	12.6 (112*)	13.6 (121*)	17.7 (157*)	6.9 (61*)	9.8 (86*)
5/16	13 (115*)	17 (149*)	20 (178*)	26 (229*)	28 (250*)	37 (324*)	14 (125*)	20 (176*)
3/8	23 (17)	30 (22)	35 (26)	46 (34)	50 (37)	65 (48)	26 (19)	35 (26)
7/16	37 (27)	47 (35)	57 (42)	73 (54)	80 (59)	104 (77)	41 (30)	57 (42)
1/2	57 (42)	73 (54)	87 (64)	113 (83)	123 (91)	159 (117)	61 (45)	88 (64)
9/16	81 (60)	104 (77)	125 (92)	163 (120)	176 (130)	229 (169)	88 (65)	125 (92)
5/8	112 (83)	145 (107)	174 (128)	224 (165)	244 (180)	316 (233)	122 (90)	172 (127)
3/4	198 (146)	256 (189)	306 (226)	397 (293)	432 (319)	560 (413)	217 (160)	306 (226)
7/8	193 (142)	248 (183)	495 (365)	641 (473)	698 (515)	904 (667)	350 (258)	494 (364)
1	289 (213)	373 (275)	742 (547)	960 (708)	1048 (773)	1356 (1000)	523 (386)	739 (545)

NOTE: Torque values shown with * are inch pounds.

Identification of Hex Cap Screws and Carriage Bolts



GRADE 2
SAE BOLT

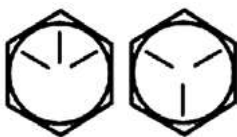

GRADE 5
SAE BOLTS



GRADE 8
SAE BOLTS



GRADE 2
SAE NUTS



GRADE 5
SAE NUTS



GRADE 8
SAE NUTS

Identification of Hex Nuts and Lock Nuts

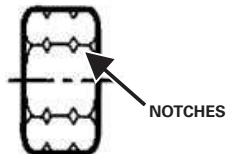

NOTCHES

GRADE IDENTIFICATION

GRADE A: NO NOTCHES

GRADE B: ONE CIRCUMFERENTIAL NOTCH

GRADE C: TWO CIRCUMFERENTIAL NOTCHES

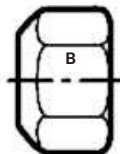

B

GRADE IDENTIFICATION

GRADE A: NO MARK

GRADE B: LETTER B

GRADE C: LETTER C

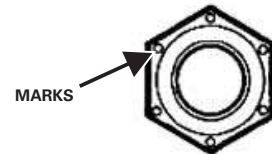

MARKS

GRADE IDENTIFICATION

GRADE A: NO MARKS

GRADE B: THREE MARKS

GRADE C: SIX MARKS

MARKS NEED NOT BE LOCATED AT CORNERS

Farm King



Warranty

Farm King Base Limited Warranty.....	63
Repair Parts Limited Warranty.....	63
What Is Not Covered.....	63
Authorized Dealer And Labor Costs.....	63
Warranty Requirements.....	64
EXCLUSIVE EFFECT OF WARRANTY AND LIMITATION OF LIABILITY.....	64

Farm King



Farm King Base Limited Warranty

Farm King provides this warranty only to original retail purchasers of its products. Farm King warrants to such purchasers that all Farm King manufactured parts and components used and serviced as provided for in the Operator's Manual shall be free from defects in materials and workmanship for a period following delivery to the original retail purchaser of one (1) year. This limited warranty applies only to those parts and components manufactured by Farm King. Parts and components manufactured by others are subject to their manufacturer's warranties, if any.

Farm King will fulfill this limited warranty by, at its option, repairing or replacing any covered part that is defective or is the result of improper workmanship, provided that the part is returned to Farm King within thirty (30) days of the date that such defect or improper workmanship is, or should have been, discovered. Parts must be returned through the selling representative and the buyer must prepay transportation charges.

Farm King will not be responsible for repairs or replacements that are necessitated, in whole or part, by the use of parts not manufactured by or obtained from Farm King. Under no circumstances are component parts warranted against normal wear and tear. There is no warranty on product pump seals, product pump bearings, rubber product hoses, pressure gauges, or other components that require replacement as part of normal maintenance.

Repair Parts Limited Warranty

Farm King warrants genuine Farm King replacement parts purchased after the expiration of the Farm King Limited Warranty, and used and serviced as provided for in the Operator's Manual, to be free from defects in materials or workmanship for a period of thirty (30) days from the invoice date for the parts. Farm King will fulfill this limited warranty by, at its option, repairing or replacing any covered part that is defective or is the result of improper workmanship, provided that the part is returned to Farm King within thirty (30) days of the date that such defect or improper workmanship is, or should have been, discovered. Such parts must be shipped to the Farm King factory at the purchaser's expense.

What Is Not Covered

Under no circumstances does this limited warranty cover any components or parts that have been subject to the following: negligence; alteration or modification not approved by Farm King; misuse; improper storage; lack of reasonable and proper maintenance, service, or repair; normal wear; damage from failure to follow operating instructions; accident; and/or repairs that have been made with parts other than those manufactured, supplied, and or authorized by Farm King.

Authorized Dealer And Labor Costs

Repairs eligible for labor under this limited warranty must be made by Farm King or an authorized Farm King dealer. Farm King retains the exclusive discretion to determine whether it will pay labor costs for warranty repairs or replacements, and the amount of such costs that it will pay and the time in which the repairs will be made. If Farm King determines that it will pay labor costs for warranty work, it will do so by issuing a credit to the dealer's or distributor's account. Farm King will not approve or pay invoices sent for repairs that Farm King has not previously approved. Warranty service does not extend the original term of this limited warranty.

Warranty Requirements

To be covered by warranty, each new product must be registered with Farm King within thirty (30) days of delivery to original retail purchaser. If the customer decides to purchase replacement components before the warranty disposition of such components is determined, Farm King will bill the customer for such components and then credit the replacement invoice for those components later determined to be covered by this limited warranty. Any such replacement components that are determined not to be covered by this limited warranty will be subject to the terms of the invoice and shall be paid for by the purchaser.

EXCLUSIVE EFFECT OF WARRANTY AND LIMITATION OF LIABILITY

TO THE EXTENT PERMITTED BY LAW, FARM KING DISCLAIMS ANY WARRANTIES, REPRESENTATIONS, OR PROMISES, EXPRESS OR IMPLIED, AS TO THE QUALITY, PERFORMANCE, OR FREEDOM FROM DEFECT OF THE COMPONENTS AND PARTS COVERED BY THIS WARRANTY AND NOT SPECIFICALLY PROVIDED FOR HEREIN.

TO THE EXTENT PERMITTED BY LAW, FARM KING DISCLAIMS ANY IMPLIED WARRANTIES OF MERCHANTABILITY AND FITNESS FOR A PARTICULAR PURPOSE ON ITS PRODUCTS COVERED HEREIN, AND DISCLAIMS ANY RELIANCE BY THE PURCHASER ON FARM KING'S SKILL OR JUDGMENT TO SELECT OR FURNISH GOODS FOR ANY PARTICULAR PURPOSE. THE PURCHASER'S ONLY AND EXCLUSIVE REMEDIES IN CONNECTION WITH THE BREACH OR PERFORMANCE OF ANY WARRANTY ON FARM KING'S PRODUCTS ARE THOSE SET FORTH HEREIN. IN NO EVENT SHALL FARM KING BE LIABLE FOR INCIDENTAL OR CONSEQUENTIAL DAMAGES (INCLUDING, BY WAY OF EXAMPLE ONLY AND NOT LIMITATION, LOSS OF CROPS, LOSS OF PROFITS OR REVENUE, OTHER COMMERCIAL LOSSES, INCONVENIENCE, OR COST OF REPLACEMENT OF RENTAL EQUIPMENT). IN NO EVENT SHALL FARM KING'S CONTRACT OR WARRANTY LIABILITY EXCEED THE PURCHASE PRICE OF THE PRODUCT. (Note that some states do not allow limitations on how long an implied warranty lasts or the exclusion or limitation of incidental or consequential damages, so the above limitations and exclusion may not apply to you.) This warranty gives you specific legal rights and you may also have other rights, which vary from state to state.

Farm King neither assumes nor authorizes any person or entity, including its selling representatives, to assume any other obligations or liability in connections with the sale of covered equipment, or to make any other warranties, representations, or promises, express or implied, as to the quality, performance, or freedom from defect of the components and parts covered herein. No one is authorized to alter, modify, or enlarge this limited warranty, or its exclusions, limitations and reservations.

Corrections of defects and improper workmanship in the manner, and for the applicable time periods, provided for herein shall constitute fulfillment of all responsibilities of Farm King to the purchaser, and Farm King shall not be liable in negligence, contract, or on any other basis with respect to the subject equipment.

This limited warranty is subject to any existing conditions of supply which may directly affect Farm King's ability to obtain materials or manufacturer replacement parts.

Buhler Industries Inc. reserves the right to make improvements in design or changes in specifications to its products at anytime, without incurring any obligation to owners of units previously sold.

www.farm-king.com

Farm King

1330 43rd Street North
Fargo, ND, 58102
Toll Free: 887.447.6008
E-mail: info@buhler.com
www.farm-king.com

Equipment shown is subject to change without notice.
©2019 Buhler Trading Inc. Printed in USATSX:BU1