



---

**MODELS 545XL / 645XL**  
**GRAIN DRYERS**  
**OPERATOR'S MANUAL**  
**& PARTS BOOK**

---



**Form S-3087-11**  
Printed in U.S.A.



P.O. Box 525 • Clay Center, KS 67432, U.S.A.  
Phone: (785) 632-2151 • Toll Free: (800) 423-9428 • Fax: (785) 632-3308  
Email: [info@gtmfg.com](mailto:info@gtmfg.com) • Website: [www.gtmfg.com](http://www.gtmfg.com)





MANUFACTURERS OF FARM AND INDUSTRIAL EQUIPMENT

MODELS 545XL / 645XL

OPERATORS MANUAL & PARTS CATALOG

INTRODUCTION

Your GT Grain Dryer is one of the finest grain dryers ever built; designed to give you excellent service for many years. The information and suggestions found in this owners manual will help you achieve this.

Your GT Grain Dryer dealer is well trained and equipped to give you complete service when and if the need should arise.

We would also like to take this opportunity to thank you for choosing GT and to assure you of our continuing interest in your complete satisfaction.

TABLE OF CONTENTS

Battery Connections . . . . .19
Bolt Torque Chart . . . . .63
Controls Identification . . . . .18
Electric Schematics . . . . .21-22
Indicator Light Check Out Procedure . . . . .26
Gas Flow Chart . . . . .17
General Information . . . . .7-8
Grain Drying Chart . . . . .64
Grain Temperature Chart . . . . .15
Parts List
Agitator Assembly . . . . .44-45
Auger Assembly . . . . .50-51
Burner Assembly . . . . .34-35
Frame Assembly . . . . .42-43
Gearbox Assembly . . . . .46
Grain Cleaner Attachment . . . . .62
Hydraulic and Electric Unloading Heads . . . . .58-59
Loading Auger . . . . .56-57
Natural Gas Controls Assembly . . . . .40-41
Nuts, Washers, and Lockwashers . . . . .63
Outside Skin Assembly 545XL . . . . .52-53
Outside Skin Assembly 645XL . . . . .54-55
Plenum Assembly . . . . .48-49
Power Unit . . . . .28-31
Propane Controls Assembly . . . . .36-38
Side Mount Panel . . . . .60-61
Solenoid Valve Assembly . . . . .39
Tumbler Assemblies . . . . .32-33
Preparing Dryer for Operation . . . . .8-15
Preparing Dryer for Storage . . . . .16
Safety Information Decals . . . . .2-6
Sequence of Operation . . . . .22
Table of Contents . . . . .1
Trouble Shooting . . . . .23-26
Wiring Diagram . . . . .20

## SAFETY



DO NOT OPERATE OR ALLOW ANYONE TO OPERATE THIS EQUIPMENT WHO HAS NOT BEEN PROPERLY TRAINED ON ITS SAFE OPERATION.

Throughout your operator's manual and at various locations on your machine you will see the Safety-Alert symbol shown below. This emblem has been adopted by the agricultural equipment industry to provide a universal symbol which means ATTENTION! BECOME ALERT! YOUR SAFETY IS INVOLVED!

This symbol is our way of telling you to pay special attention to the instructions or warnings which follow because your safety is involved.

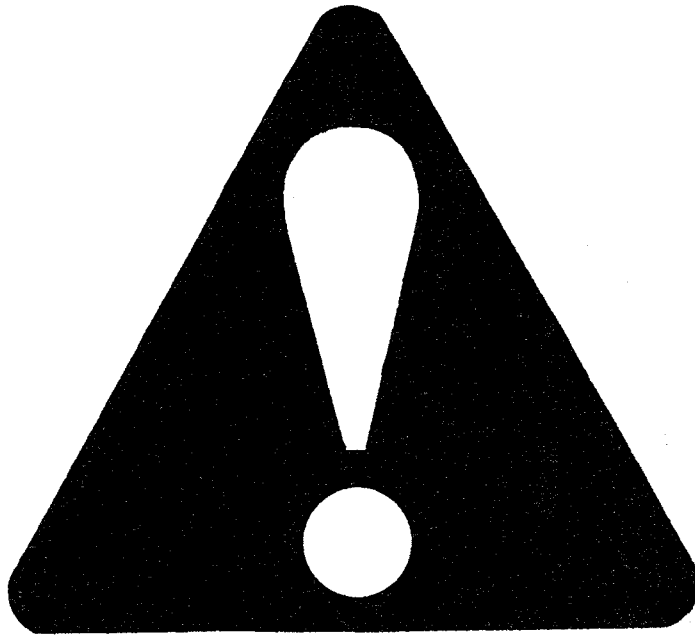

### SAFETY-ALERT SYMBOL FOR AGRICULTURAL EQUIPMENT

The following labels found on your machine provide important safety messages and instruction for safe operation.



As these labels become worn, damaged, or illegible replace them immediately. These labels are available at your authorized dealer.

# BE A SAFE OPERATOR

BY THINKING – BEFORE ACTING

AND

BY READING YOUR OPERATIONS MANUAL

## AVOID ACCIDENTS

Most accidents, whether they occur in industry, on the farm, at home, or on the highway, are caused by the failure of some individual to follow simple and fundamental safety rules or precautions. For this reason most accidents can be prevented by recognizing the real cause and doing something about it before the accident occurs.

Regardless of the care used in the design and construction of any type of equipment, there are many conditions that can not be completely safeguarded against without interfering with reasonable accessibility and efficient operation.

A CAREFUL OPERATOR IS THE BEST INSURANCE AGAINST AN ACCIDENT.

THE COMPLETE OBSERVANCE OF ONE SIMPLE RULE WOULD PREVENT MANY THOUSAND SERIOUS INJURIES EACH YEAR. THAT RULE IS:

STOP MACHINE TO ADJUST, LUBRICATE, SERVICE, CLEAN OR MOVE.



# CAUTION

1. Read and understand the Operator's Manual before operating the unit.
2. Keep children, visitors and all untrained personnel away from machine while in operation.
3. Keep all shields and safety devices in place.
4. Stop machine to adjust, lubricate, service, clean or move.
5. Keep hands, feet and clothing away from moving parts.
6. Disconnect electrical power before servicing.
7. Keep unit level when operating.
8. Maintain proper tire pressure when transporting machine. (Refer to Manufacturers Recommendations.)



# DANGER

For maximum safety and smoothest operation keep p.t.o. shaft in closed position while under load. Keep u-joint angles equal. Do not remove safety shields. Do not exceed 540 r.p.m.

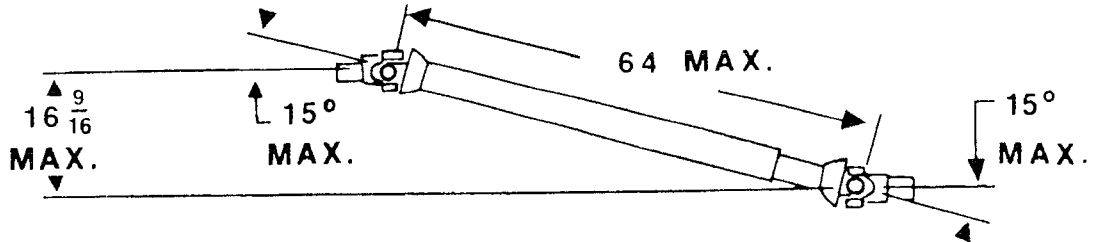

**FAILURE TO HEED WILL CAUSE PTO SHAFT FAILURE OR SEPARATION & RESULT IN SERIOUS INJURY OR DEATH.**



# DANGER



**ROTATING DRIVELINE  
CONTACT CAN CAUSE DEATH  
KEEP AWAY!**

**DO NOT OPERATE WITHOUT —**

- ALL DRIVELINE, TRACTOR AND EQUIPMENT SHIELDS IN PLACE
- DRIVELINES SECURELY ATTACHED AT BOTH ENDS
- DRIVELINE SHIELDS THAT TURN FREELY ON DRIVELINE

L1

279561

# DANGER

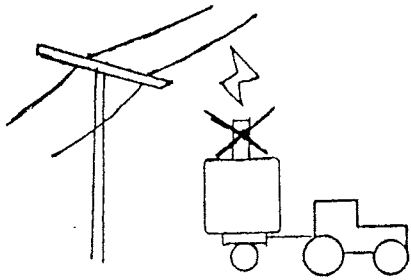

## ELECTROCUTION HAZARD

To prevent serious injury or death from electrocution:

- Remove unloading head when transporting.
- Stay away from overhead power lines when transporting.
- This machine is not grounded.
- Electrocution can occur without direct contact.



# DANGER

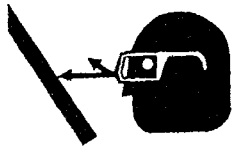

CONNECT TO LIQUID PROPANE ONLY.

Wear Rubber Gloves and Eye Protection.

Avoid Contact with Propane.



Check for Leaks with Soap and Water. NEVER USE FLAME.

# CAUTION

ENGAGE FAN CLUTCH  
VERY SLOWLY WHEN  
PTO IS OPERATING



**MAX. PTO SPEED 540 R.P.M.**

TORQUE WHEEL BOLTS TO 70 LB.-FT.  
(94.85 N-M). CHECK TORQUE  
BEFORE TOWING AND PERIODICALLY  
UNTIL TORQUE IS HELD.

74535

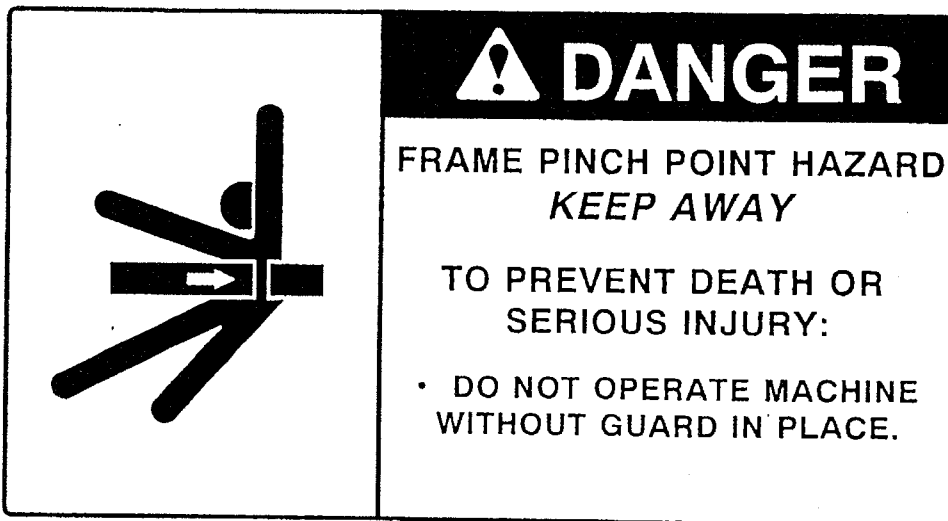





1. Keep all guards and shields in place.



2. Inspect your drive before adding power and know how to shut down in an emergency.



3. Stop all moving parts before allowing anyone to approach the equipment for cleaning, unplugging, adjusting, performing maintenance or any other duty.



4. Replace all safety shields/guards before restarting.



5. Replace all safety shields/guards as they become worn, damaged, unusable, missing or lost.

## GENERAL INFORMATION

Mechanical drying of grain is a relatively new process; therefore, emphasis must be placed on proper operation of grain drying equipment. Your GT dryer was designed and engineered to retain grain quality, and to dry grain as rapidly as possible at the lowest cost consistent with retention of quality grain. Study and follow this manual so you may enjoy the additional profits derived from drying.

### THEORY OF DRYING

The theory of drying has two basic stages: (1) diffusing of internal moisture to the surface of the kernel, and (2) removal of external moisture by air flowing around the kernel. Vapor pressure is increased inside the kernel which causes moisture to diffuse through the micropores of the seed coat. The grain temperature largely establishes this rate of diffusion and hence must be controlled to not exceed a maximum rate which would result in a ruptured kernel.

Removal of the exterior moisture for a given air flow is dependent upon the air temperature. These two stages must be balanced to produce quality dried grain.

This balance is accomplished quite simply in the GT Grain Dryer with its uniform circulation, regulated heat, and controlled air flow.

### RATE OF DRYING

In addition to the kind and variety of grain, the drying rate is controlled by atmospheric conditions. Hard and fast rules cannot be set forth because of these variables. It will be necessary to dry several batches to determine the exact dryer settings in a specific area. A chart for recording necessary information for later use is included in the back of this manual.

### WHEN GRAIN IS MATURE.

Grain is mature at 30% to 35% moisture. While some grain may be harvested easily at 30%, others do not harvest well above 20%. Therefore, grain should be harvested as soon as possible after maturity, as long as grain damage is at a minimum and gleaning is thorough.

### STORAGE MOISTURE LEVELS

To properly store grain, the grain moisture content must be compatible with the length of time the grain will be in storage, and with the grain's intended use. This moisture content will vary due to locale.

GRAIN	1 YEAR STORAGE (% Moisture)
Corn	13%
Wheat	13-14%
Barley	13%
Rice	12%
Oats	13%
Rape Seed	10.5%
Grain Sorghum	12%
Flax	9%
Soybeans	11%
Edible Beans	14-16%
Sunflower Seed (Oil Type)	10%
Sunflower Seed (Bird Seed Type)	12%

Corn may be stored at 15% moisture if moved before warm spring weather. For long term storage – up to 5 years, or for grain stored as seed stock, moisture level should be 2% lower than shown above.

### MOISTURE TESTING

Since grain must go into storage at not more than specified moisture content, it is necessary to use a reliable tester to determine moisture content. When marketing grain from the dryer, it should be only dry enough to eliminate moisture discounts. The moisture tester may also be profitably used to determine when to harvest.

### COOLING OF GRAIN

It is very important to cool grain. Grain being put in storage should be cooled after drying to within 20 degrees F of atmospheric temperature or, 10 degrees F of grain already in the storage bin. Moisture migration from the air to grain will occur if the grain is not cooled to these limits.

## PREPARING DRYER FOR OPERATION

### 1. INSTALLATION OF EQUIPMENT

The equipment shall be installed in accordance with the installation code for gas burning appliances and equipment, Canadian Standard's Association B 149, or applicable state or Provincial Regulations for the class. Instructions should be carefully followed in all cases. Authorities having jurisdiction should be consulted before installations are made.

### 2. PLACING MACHINE FOR OPERATION

Select a site as level as possible, 50 ft. (15 meters) from inflammable buildings. Set machine, if possible, with fan into prevailing winds. Lower the supporting legs (6 on Model 545) and insert pins. If machine is being set on a level concrete slab, no additional blocking will be necessary. However, if being set on dirt, at least 2" x 8" x 12" board or equivalent should be placed under each leg for additional flotation. Add any additional blocking material necessary to bring machine level. Use a level on main frame to determine this.

### 2. INSTALLING TOP SECTION OF AUGER AND ADJUST FOR UNLOADING

When installing the top section of auger, it may be necessary to jack the lower flight up to allow the bolt holes in the connecting shaft to align. The weight of the complete auger should be supported by the top auger bearing when in proper adjustment.

If the dryer is equipped with the standard swivel head, removing bolts through mounting flanges which hold the upper and lower auger tubes together will allow the upper tube to be rotated to provide unloading at several points. It should be also noted that on the standard swivel head when the unloading spout is set for unloading one direction, it will also unload in the opposite direction. One-fourth turn, of unloading spout, relocates the auger head to recirculating position. When unloading or recirculating, the unloading spout must rest

in holders provided at top of bin. These holders may be relocated by drilling bin wall and rebolting holders. Should use of both unloading positions be desired, an additional holder may be obtained through your dealers parts department. Be sure that the openings in the upper auger tube and the auger head are properly aligned to insure good circulation.

If the dryer is equipped with the hydraulic drive horizontal top unloading head, the discharge should be set directly off the right or left hand sides of the dryer. It is recommended that the hydraulic lines to the drive motor be connected to a source with a capacity of 7 gallons per minute at 1000 psi.

After connecting hydraulic source to lines at dryer, make certain that the unloading flight has the proper rotation to remove grain from the head. When looking into the discharge end of the auger it should be rotating counter clockwise.

When using the horizontal unloading head, it is not advisable to leave grain set in the dryer for any length of time (such as over night) without the vertical auger operating. If grain must be left in the dryer, it should be lowered to a level below the top of the unload auger head to prevent grain from running back down the vertical auger.

#### 4. LOCATING PROPANE GAS SUPPLY TANK

Location of the Propane Gas Supply Tank must be in accordance with local, state or provincial regulation. It should also be approved by the insurance company. A minimum distance of twenty-five (25) ft. (7.5 meters) is recommended for safety and will allow room for maneuvering grain hauling equipment.

GT Propane Gas fired dryers are equipped with Vaporizers and must be connected to the supply tank for LIQUID withdrawal. It is recommended that rubber hose specifically made for Propane gas be used as a supply line connecting tank to dryer. Specifications for the line are: (1) minimum working pressure 350 psi, (2) minimum bursting strength 1,750 psi, and (3) ½" minimum inside diameter for Model 545. Tank pressure is used at the dryer; therefore, it is not necessary to install a pressure regulator at the tank.



#### DANGER

All lines and fittings should be checked periodically for leaks before and during operation. Check for leaks with liquid detergent suds or comparable substance, but NEVER with flame.



#### CAUTION

Do not use storage tanks that have been used to store Anhydrous Ammonia. This causes corrosion to the gas line controls.

Always protect gas supply line against vehicle or animal damage.

#### 5. NATURAL GAS

Specifications for Natural Gas connections are available from the gas supplier and must be adhered to. The Model 545 dryer will require up to 20 psi, depending on locality. Pressure shown is at the dryer. Maximum Natural Gas volume required is up to 50 ft<sup>3</sup> per minute on the Model 545.

#### 6. ELECTRICAL CONNECTIONS

Power take off machines have as standard equipment a 12 VDC negative ground control circuit. The lead in wires must be properly connected to the tractor battery. Red clip to hot (+) side of battery and black clip to ground (-) side of battery. See proper battery connections on page 19.

**IMPORTANT:** Battery connections other than that described above will be harmful to the ignition system.

## 7. LUBRICATION

Use a high-low temperature grease or equivalent made especially for ball and roller bearings in extreme temperatures.

Refer to the following chart for location of lubrication points and frequency of lubrication. A small amount of grease at the specified intervals is recommended over a large amount at less frequent intervals.

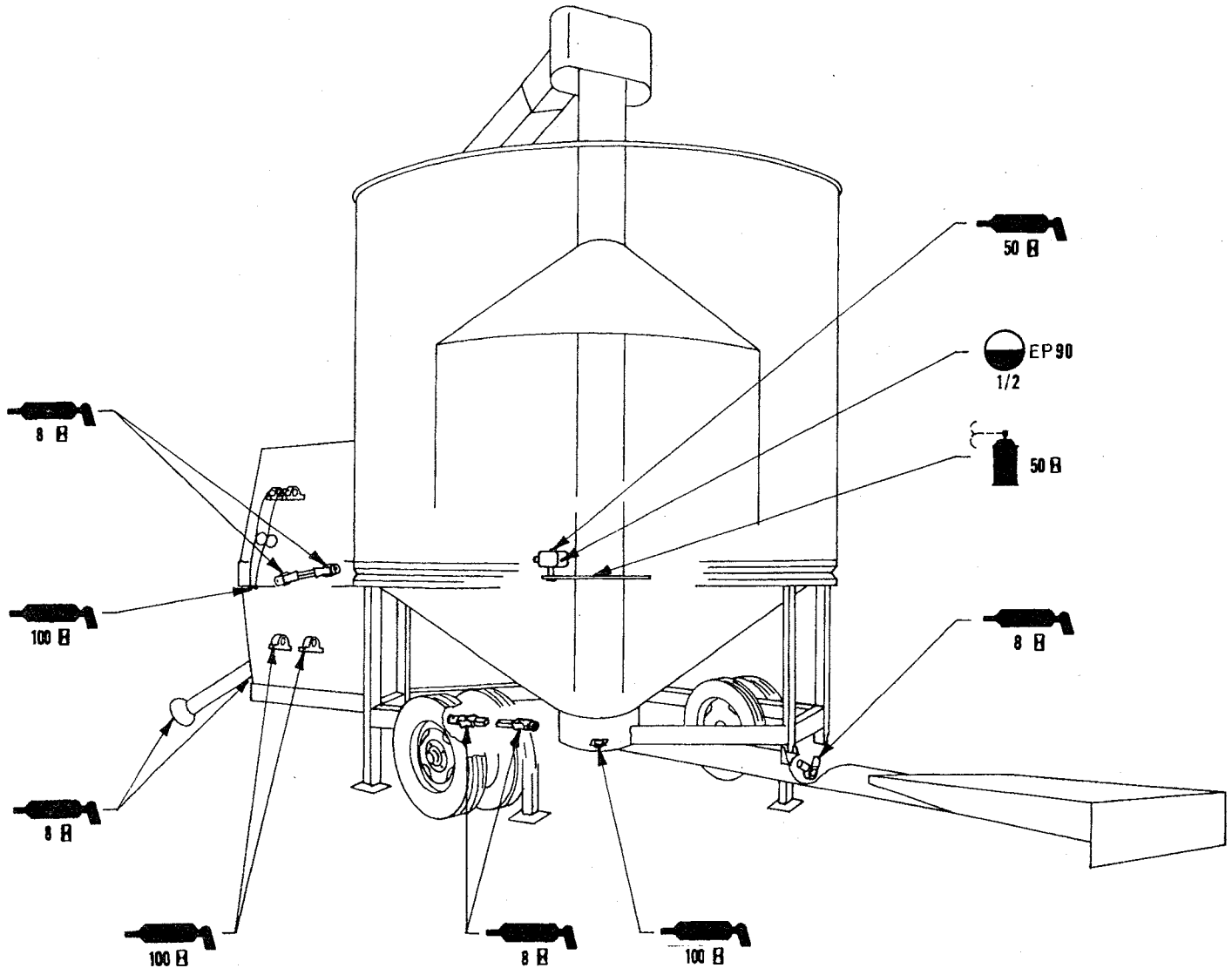

Symbol descriptions:

 Grease Point

x8 Lubrication Frequency (Hours of Operation)

 Gearbox Oil Level & Type

 Dry Film Spray Lubricant

When performing the 100 hour lubrication, check to see that set screw in bearing and tumblers are tight.

**IMPORTANT:** In extremely cold weather, it may be necessary to operate the dryer at a low RPM for a short period of time to allow the grease in the bearings to warm up.

## 8. SERVICING AND CARE OF AGITATOR

It is important that the agitator be inspected before and after the first load. Then after each 100 hours of operation.

- A. The tapered agitator rollers must support the plate sprocket so there is no horizontal movement of sprocket.

The Model 580 has four rollers mounted on the agitator sprocket so each roller supports an equal load. These rollers are tapered so all horizontal and vertical slack may be taken up.

### B. Adjusting Rollers

1. Secure the cam nut and loosen the bolt.
2. Rotate the cam nut counter-clockwise (when looking down into the cam nut) while holding the bolt stationary.
3. Secure the cam nut and tighten the bolt.
4. All cam nuts must be rotated an equal amount so the agitator sprocket remains true.
5. Rotate agitator arms by hand and check clearance.

NOTE: Agitator drive chain is provided with a spring loaded idler, however, it is necessary to periodically check the chain slack.



### CAUTION

Do not open inspection door or enter machine while in operation.

## 9. BELT TENSION

With machine running at normal speed, belts should be tight enough to keep out the slack. Keep belts tight to prolong life.

## 10. VAPORIZER (Propane Only)

The vaporizer is designed for year round operation. However, the temperature of the vapor controls (pressure regulator, solenoid valves, ball valve, etc.) can be adjusted by moving the vaporizer ring up or down relative to the burner ring. The controls will run warmest with the vaporizer ring directly in line with the burner controls. The temperature of the vapor controls can also be adjusted by moving the vaporizer ring closer or farther from the burner by changing the position of the vaporizer on the burner in the clamp. The vapor plumbing under normal conditions should be operating at a temperature of approximately 120F to 140F. The temperature may be checked by placing your bare hand on the plumbing and will range from warm to hot.

If the vaporizer has been overheated causing possible rupture you will be unable to control the plenum temperature. Check propane tank for liquid withdrawal. Vapor withdrawal will cause over-heating of the vaporizer and possible damage to the gas controls.

## 11. CHECK OUT - BEFORE LOADING

All piping and burners have been checked and test fired at the factory. It is possible, however, that some of the connections may have been loosened or damaged during shipment. After connecting supply tank to dryer all connections should be tested under pressure with gas pressure on. **DANGER:** Check with liquid soap solution, never with flame. Tractor can be started and dryer test run before loading with grain.

## 12. LOADING THE BIN

NOTE: The fan clutch can be disengaged during loading and unloading of dryer to lower the energy requirement. It also reduces the amount of dirt and dust which is blown out of the dryer during the load and unload cycle.

When the loading attachment is not used, overhead bins or a conventional farm type elevator or auger may be used. In using any method of filling from the top, make delivery of grain into dryer as near to center as possible. Start machine, without burner, at the same time loading begins. This helps keep bin loaded evenly. Bin will fill to rim and pyramid evenly to auger outlet.

When the loading hopper attachment is used for filling the dryer, follow these steps to prevent the grain from being fed into the dryer faster than the vertical auger can recirculate it. When this happens the grain can build up in the bottom of the dryer until it gets into the agitator assembly and causes damage to the agitator.

- A. Make sure that the vertical auger drive belt is kept tight and is not slipping.
- B. Make sure the discharge holes at the top of the vertical auger housing are completely open with the swivel head in the recirculating position.
- C. Make sure that the bottom auger well is kept clean of trash or fine material build up which restricts the flow of grain into the intake of the vertical auger.
- D. The vertical auger flighting cannot be worn down at the intake end.
- E. Slow down the PTO speed to approximately 450 RPM when filling the dryer with lightweight grains such as sunflower seeds, oats, etc.
- F. Set the grain flow regulator in the loading hopper down 1 1/2" as shown in the drawing.

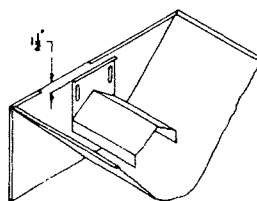

### DO NOT LEAVE GRAIN IN DRYER OVERNIGHT

## 13. STARTING THE BURNER (PROPANE)

- A. Fan should be at operating speed, approximately 2200 RPM for Model 545. This speed can be obtained by approximately 525 RPM PTO speed, however, a lower fan and PTO speed is recommended in some conditions.
- B. Check the Plenum and grain temperature controls in the control box for proper setting. (Refer to instructions No. 16 and 17 in this manual.) Re-set the controls if necessary.
- C. NOTE: For other than initial starting, skip to step H and continue.  
For initial starting, the ball valve and quick acting valves should be open, and the high pressure regulator handle should be turned out (counter-clockwise) until the screw turns freely, then turn back in (clockwise) one full turn.
- D. Move power switch to the "on" position. Depress and hold burner start switch, and at the same time turn the regulator screw clockwise until burner lights. Hold start switch depressed until flame detector is activated, usually 20 to 30 seconds.

- E. If frost should appear on the gas lines wait 2 to 3 minutes to allow the vaporizer to heat before increasing the gas pressure.
  - F. Gradually increase the plenum temperature by screwing the pressure regulator handle in (clockwise). If frost appears on the line at any time wait a few minutes before increasing pressure further. Continue to increase the gas pressure until the plenum temperature is at least 10° F above the desired operating plenum temperature. NOTE: In extreme temperature changes, it may be necessary to go more than 10°F above the desired plenum temperature.
  - G. For restarting the burner it is not necessary to change the setting of the pressure regulator unless a different plenum operating temperature is desired. Simply turn the ball valve handle so that it is only partially (one quarter) open. Open the quick acting valve.
  - H. Move power switch to the "on" position. Depress and hold burner switch, and at the same time turn the regulator screw clockwise until burn lights. Hold start switch depressed until flame detector is activated, usually 20 to 30 seconds.
  - I. After flame is established gradually open the ball valve until completely open. NOTE: Opening the ball valve too rapidly may cause frost to form in the gas lines.
14. **ADJUSTMENT OF FUEL – AIR MIXTURE**  
Your burner is factory set for correct air input for various pressures. Burner will not operate properly unless fan is at the approximate recommended operating speed.
15. **ASSEMBLY OF CONTROLS**

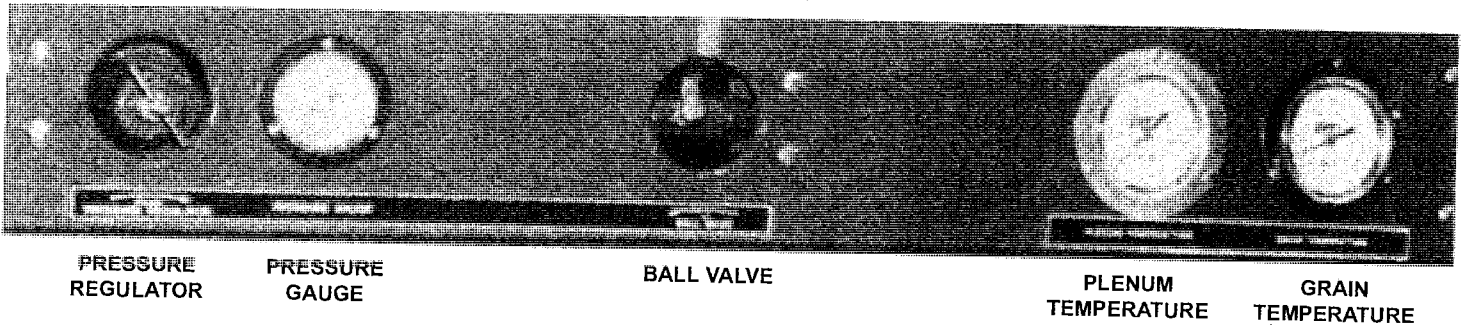

## 16. PLENUM TEMPERATURE RANGES FOR DRYING

GRAIN	PLENUM TEMP (°F) IF GRAIN TO BE USED FOR SEED	PLENUM TEMP (°F) IF GRAIN TO BE SOLD COMMERCIALY OR USED FOR ANIMAL FEED
Shelled Corn	140° – 180°	200° – 230°
Wheat	100° – 150°	150° – 180°
Grain Sorghum	140° – 180°	230° – 250°
Barley	120° – 170°	180° – 200°
Oats	140° – 180°	200° – 230°
Soybeans	120° – 170°	180° – 200°
Rough Rice	90° – 120°	140° – 160°
Flax	90° – 120°	140° – 160°
Rape Seed	90° – 120°	140° – 160°
Edible Beans	10° – 15°	
	above outside air temp.	
Sunflower Seeds (Oil Type)		110° – 150°
Sunflower Seeds (Bird Seed)		110° – 150°

### ADJUSTING PLENUM CONTROL

The plenum temperature control is located inside the control box and is used to set the desired drying temperature inside the plenum chamber. Use the above chart as a guide to set the control. The actual plenum temperature will go approximately 5°-10° above or below the specified setting on the control.

## 17. ADJUSTING GRAIN TEMPERATURE CONTROL (See No. 9, page 18)

The grain temperature control is located inside the control panel and serves to prevent over-heating of grain. When the grain temperature gets above the dial setting the control will shut the burner off and the red grain temperature light will come on. Check periodically. Refer to chart under maximum temperature of grain. ( See Page 15.)

To initially set the grain temperature control turn the dial setting to about 10° or 20°F above the “commercial use” grain temperature in the following table. (NOTE: When drying grain for seed purposes refer to instructions in next paragraph.) Example: Shelled corn for commercial sale; set dial at 140° or 150°F. As the batch is drying, periodically take grain samples from the sampler tube and check the moisture content on an accurate moisture tester. When the moisture gets within 1 – 1½ percentage points of the desired final moisture content slowly turn the dial on the grain temperature control down until the gas is shut off this extinguishing the burner. Let the grain cool to the desired temperature. The grain will continue to dry during the cooling process so should be near the desired dryness after cooling. If the grain is still a little too wet raise the temperature control setting one or two degrees on the next batch. If the grain was a little too dry lower the temperature control setting one or two degrees on the next batch.

When drying grain for seed purposes set the grain temperature control at or slightly below the temperature specified in the malt or seed column of the grain temperature chart. The plenum temperature should be set according to the seed column of the plenum temperature chart. When the grain in the dryer reaches the control setting the burner will be extinguished. Check the moisture content of the grain in the dryer. If this batch of grain is too wet, lower the plenum temperature slightly for the next batch. Lowering the plenum temperature will increase the drying time and therefore decrease the grain moisture. Conversely, if the batch of grain is too dry, raising the plenum temperature slightly for the next batch will decrease the drying time and therefore increase the grain moisture. Do not exceed maximum plenum or grain temperature shown in charts.

The grain temperature control serves as an indicator to degree of dryness, but settings must be ascertained at user level. For recording temperatures used, a sheet is provided in back of this manual. Each batch should be tested to be sure the proper moisture level is reached. Different varieties of the same grain may require different grain temperature settings to achieve the same degree of dryness.



## GRAIN DRYING INFORMATION

MAXIMUM TEMPERATURE FOR GRAIN WHEN CROP IS USED AS CHART INDICATES

GRAIN	MALT OR SEED	COMMERCIAL USE	ANIMAL FEED
Shelled Corn	110° F	130° F	140° F
Wheat	105° F	120° F	140° F
Grain Sorghum	110° F	140° F	140° F
Barley	105° F	120° F	140° F
Oats	105° F	140° F	140° F
Rye	105° F	140° F	140° F
Soybeans	105° F	120° F	140° F
Rough Rice	110° F	110° F	140° F
Flax	110° F	120° F	110° F
Rape Seed	110° F	120° F	
Edible Beans		120° F	
Sunflower Seed (oil type)		Does not apply	
Sunflower Seed (bird seed)		100° F	
		90° F	

### 18. WHEN TO TURN OFF THE BURNER

The burner can be extinguished either manually by the Off-On switch or automatically by the grain temperature control when the grain reaches the desired dryness. This can be determined by use of a moisture tester. Allow the fan to run until the grain cools to about 20° above the outside temperature or 10° above grain in storage. Grain will dry as much as 1% during the cooling period, depending on the relative humidity.

### 19. UNLOADING

After grain has cooled, swing the unloading spout to the unloading position if dryer is equipped with the standard swivel head or engage hydraulics to motor if equipped with horizontal unloading head.

### 20. DRYER NOT IN USE

When dryer is not in use, the hand valve under the control panel and the circuit breaker switch in the control panel must be in "OFF" position. The supply line should be shut off at the tank also. If location is such as to permit traffic or livestock between dryer and supply tank, protection of supply line is a must.

NOTE: When shutting the burner off for an extended period of time (even overnight) it is a good safety practice to shut the gas off at the supply tank and let all of the gas in the lines burn out.

### 21. GENERAL OPERATING MAINTENANCE

- (1) Keep area clean of shucks, chaff and other combustible material.
- (2) Keep Fan Screen cleaned.
- (3) Drain propylene out of oil trap pipe in upper plumbing weekly.
- (4) All controls should be cycled and checked periodically.
- (5) Screen in supply line strainer checked and cleaned periodically.
- (6) Check all belts for tension
- (7) Lubricate bearings as outlined.
- (8) Depending on operating and fuel conditions the burner ports may need to be cleaned periodically. Working from inside the plenum chamber and using a 5/64" diameter drill bit or torch tip cleaner open up the burner ports.
- (9) Keep all safety decals and operating instructions clean and legible. If any decals become non-legible, they should be replaced.

REMEMBER!!! an ounce of prevention is worth a pound of cure.

## PREPARING DRYER FOR STORAGE

- (a) Open clean out door on bottom well, clean out all grain.
- (b) With masking tape or equivalent, seal holes in air switch tube, and openings in fuel system.
- (c) Relax belts.
- (d) Brush protective coating of oil on agitator roller & chain.
- (e) Lubricate all bearings.
- (f) Inspect for worn or damaged parts which should be replaced before being used again.
- (g) Set jacks to support dryer weight.

## PREPARING DRYER FOR USE – OUT OF STORAGE

- (a) Remove masking tape covering openings.
- (b) Tighten Belts.
- (c) Lubricate all bearings.
- (d) Make certain bottom well is clean and close clean out door just prior to using.
- (e) Close plenum access door.
- (f) Check burner ports and clean if necessary. See item (8) of general operating maintenance.
- (g) Test fire the burner and check out all the controls to make sure they are working properly.
- (h) Level dryer and make certain the weight is equally distributed on the jacks.
- (i) Check safety and operating decals. If any are not legible they should be replaced.

## 22. TRANSPORTING THE DRYER

- a) Make certain the hitch pin is securely attached and an alternate hitch safety chain is secured to the dryer and towing vehicle.
- b) Do not transport the dryer at speeds in excess of 20 MPH (32 KPH) and comply with any local regulations governing marking, towing and maximum width.
- c) Do not transport the dryer after dark or during periods of poor visibility.
- d) Be alert to overhead obstructions and wires. Failure to do so will result in injury or electrocution. Removal of the top auger section is recommended before towing.
- e) Maintain proper tire pressure. (Refer to tire manufacturer's recommendations on the side wall.)

# MAINTENANCE SERVICE AND TROUBLESHOOTING FOR GT GRAIN DRYERS

## PROPANE GAS FLOW CHART

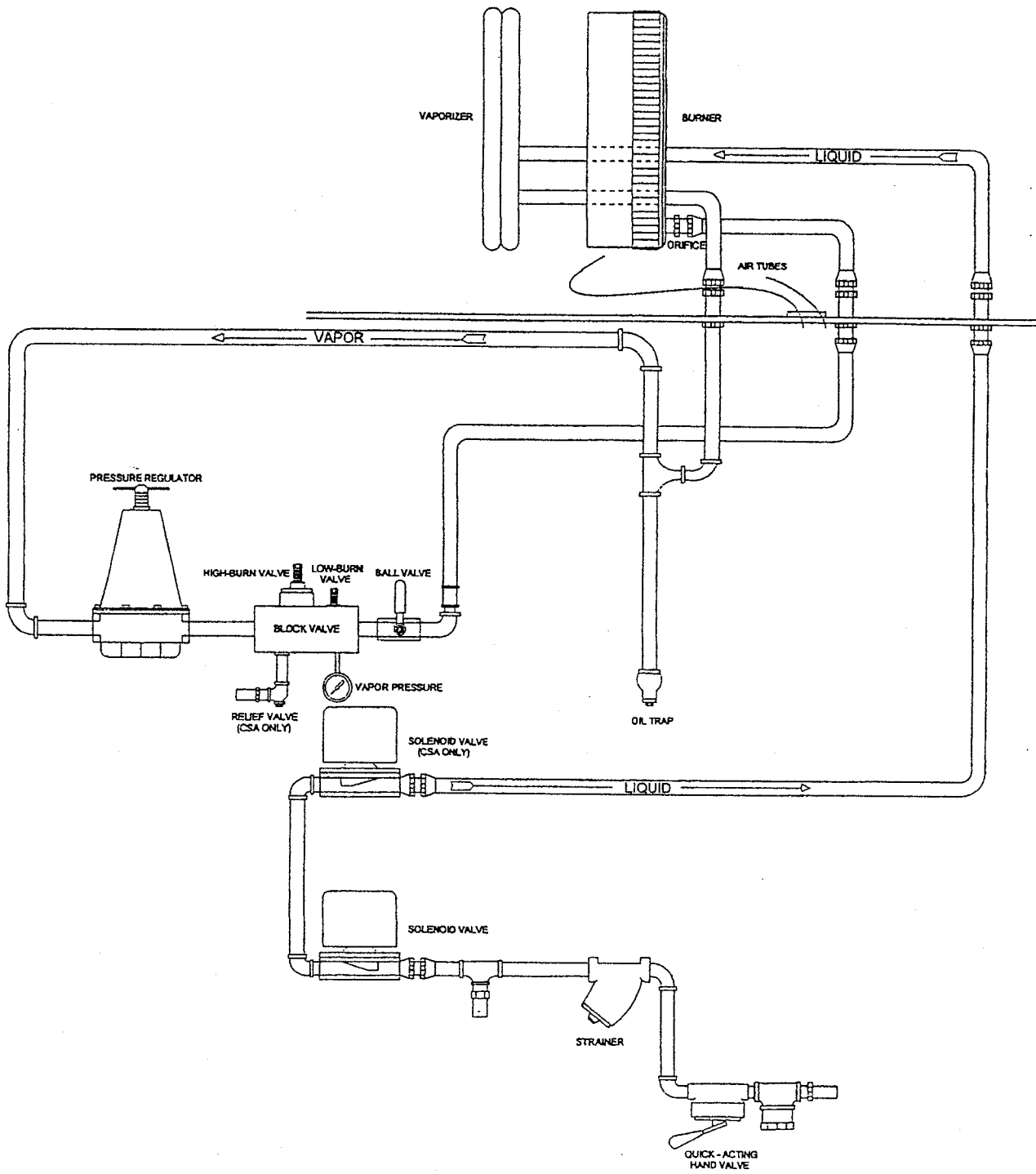

THIS PICTURE SHOWS ALL COMPONENTS OF THE CONTROL SYSTEM OF THE GT DRYER. ALL PARTS ARE NUMBERED AND IDENTIFIED BY DESCRIPTION. THE FOLLOWING PAGES OF THIS MAINTENANCE AND SERVICE BULLETIN REFER TO THE INFORMATION CONTAINED HEREIN.

STUDY THIS INFORMATION. IT WILL GREATLY ASSIST YOU IN THE OPERATION OF YOUR DRYER.

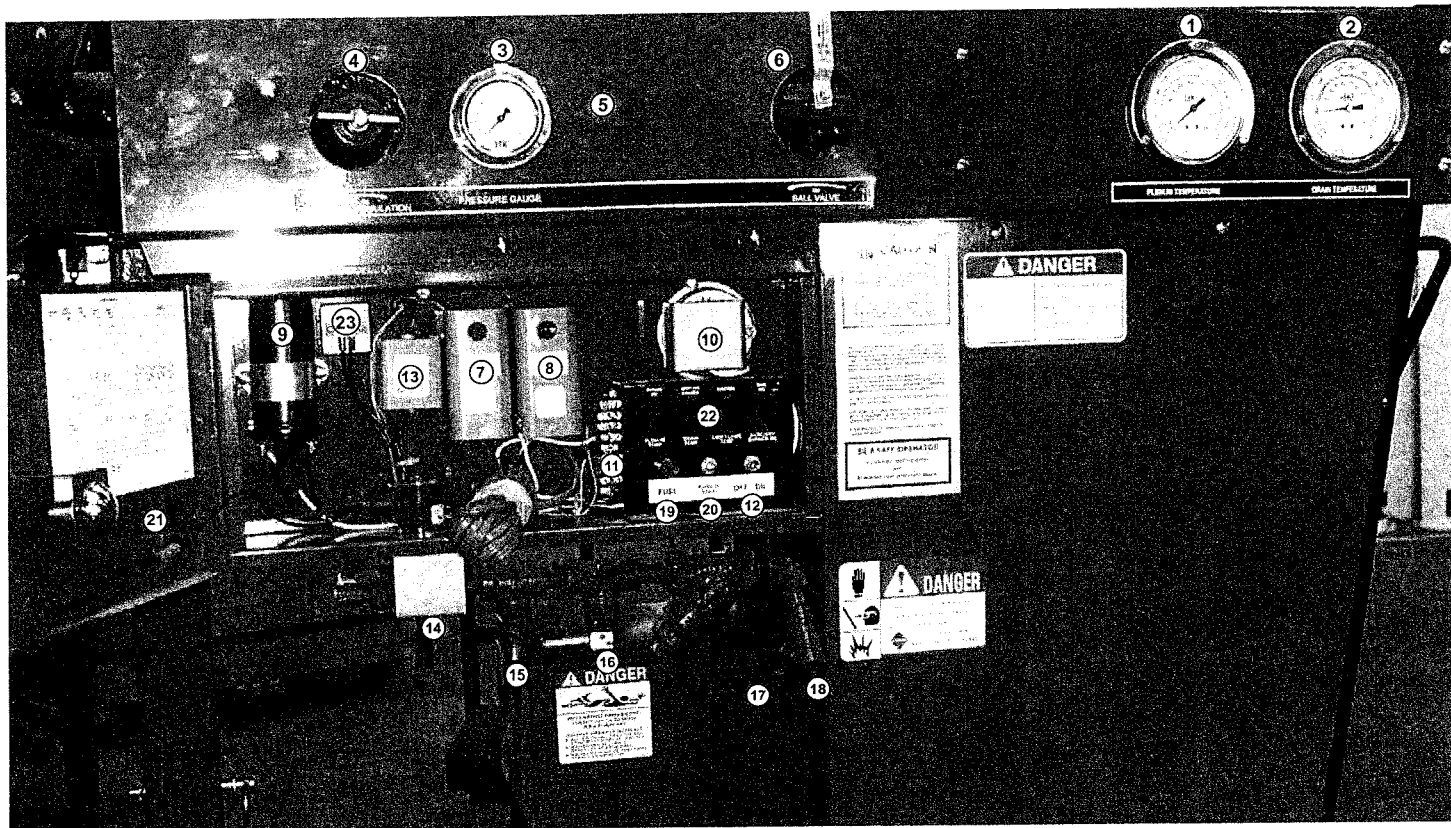

- |     |   |     |                              |
|-----|---|-----|------------------------------|
| 1.  | Plenum Thermometer                                | 12. | On-Off Switch (Power Switch) |
| 2.  | Grain Thermometer                                 | 13. | Flame Detector               |
| 3.  | Pressure Gauge                                    | 14. | Solenoid Valve - Liquid      |
| 4.  | Pressure Regulator                                | 15. | Pressure Relief Valve        |
| 5.  | Solenoid Block<br>(located directly behind panel) | 16. | Manual Valve - Propane       |
| 6.  | Ball Valve  | 17. | Strainer                     |
| 7.  | Plenum Control                                    | 18. | Propane Inlet                |
| 8.  | Grain Control, Temperature                        | 19. | Fuse                         |
| 9.  | Ignition Coil                                     | 20. | Start Switch                 |
| 10. | Air Switch  | 21. | Panel Light                  |
| 11. | Terminal Block                                    | 22. | Indicator Lights             |
|     |   | 23. | Spark Booster                |

# BATTERY CONNECTIONS

## 12 VOLT SYSTEM (ONE 12 VOLT BATTERY)

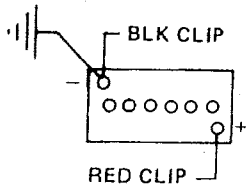

CORRECT

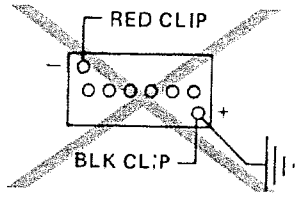

INCORRECT

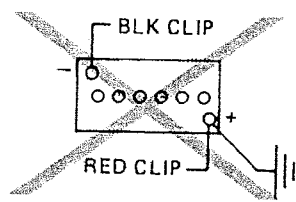

INCORRECT

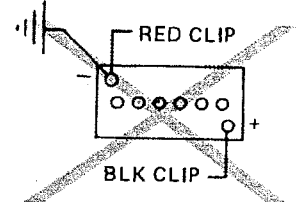

INCORRECT

## 12 VOLT SYSTEM (TWO 6 VOLT BATTERIES)

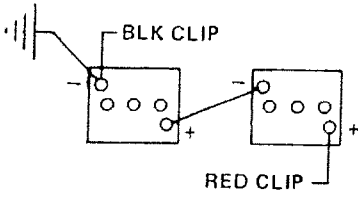

CORRECT

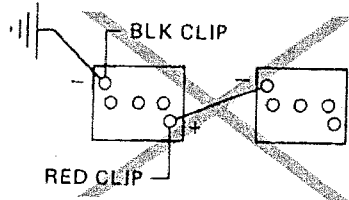

INCORRECT

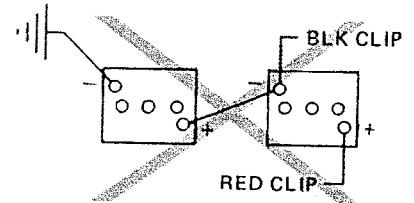

INCORRECT

## 12 VOLT SYSTEM (TWO 12 VOLT BATTERIES)

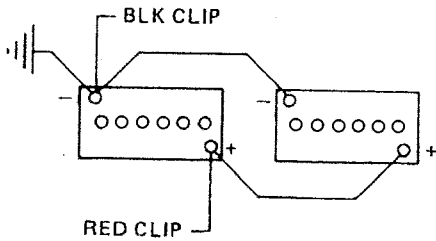

CORRECT

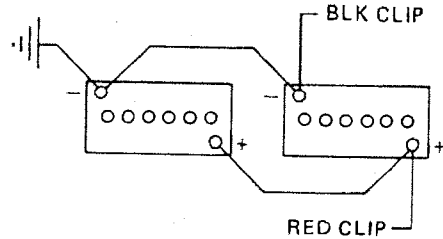

CORRECT

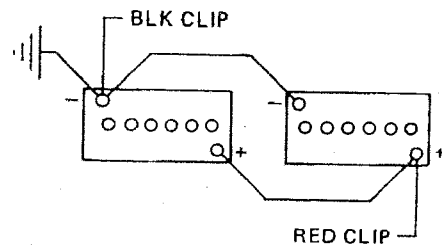

CORRECT

## 24 VOLT SYSTEM (TWO 12 VOLT BATTERIES)

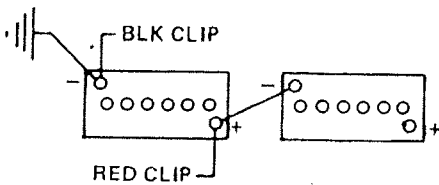

CORRECT

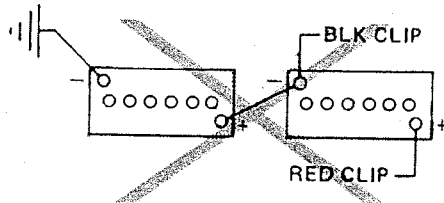

INCORRECT

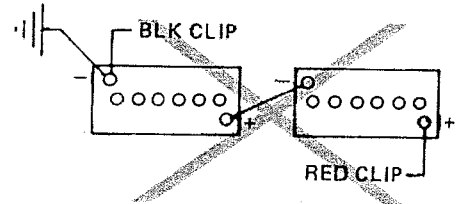

INCORRECT



# WIRING DIAGRAM

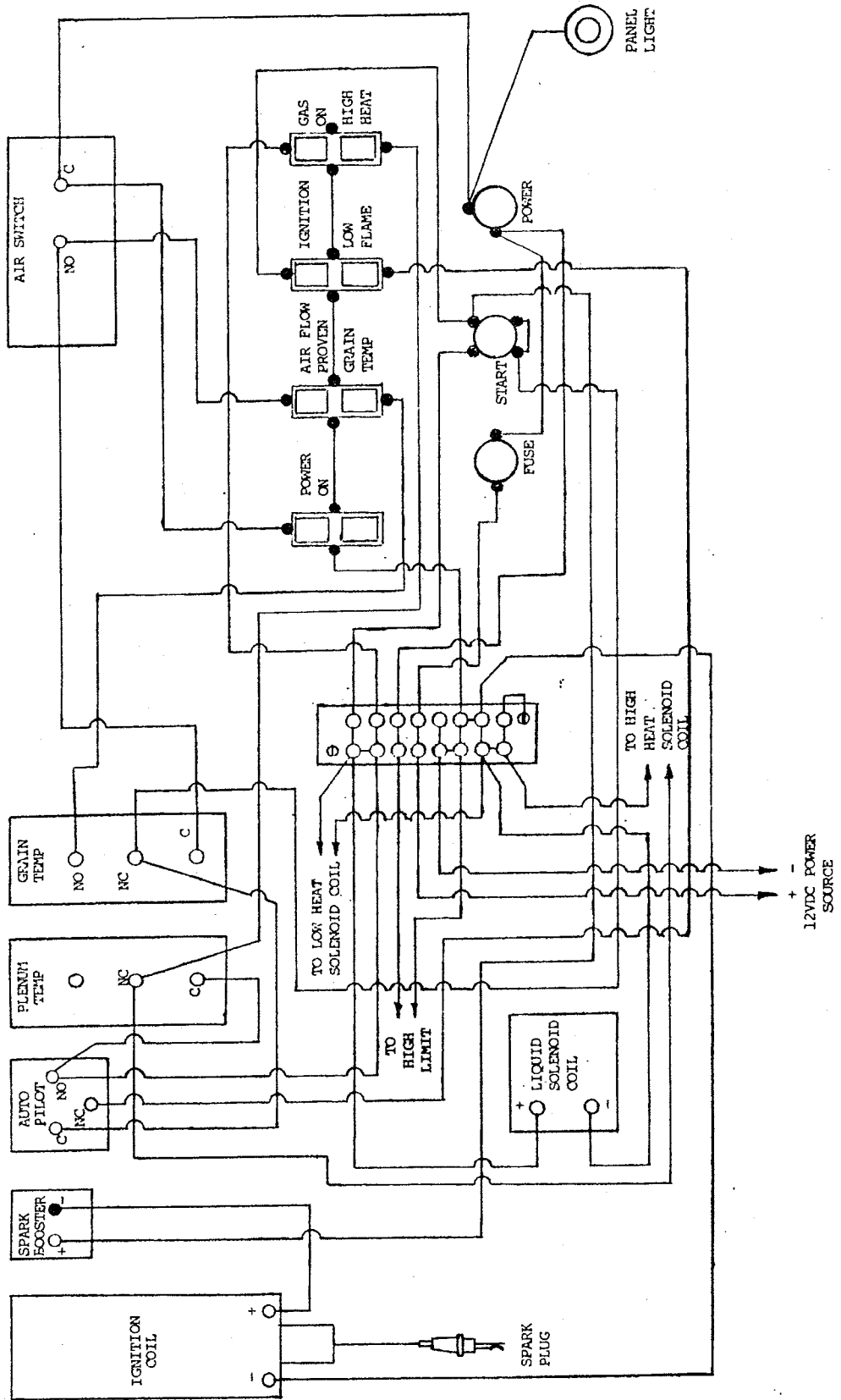

# ELECTRIC SCHEMATIC - NON MICRO

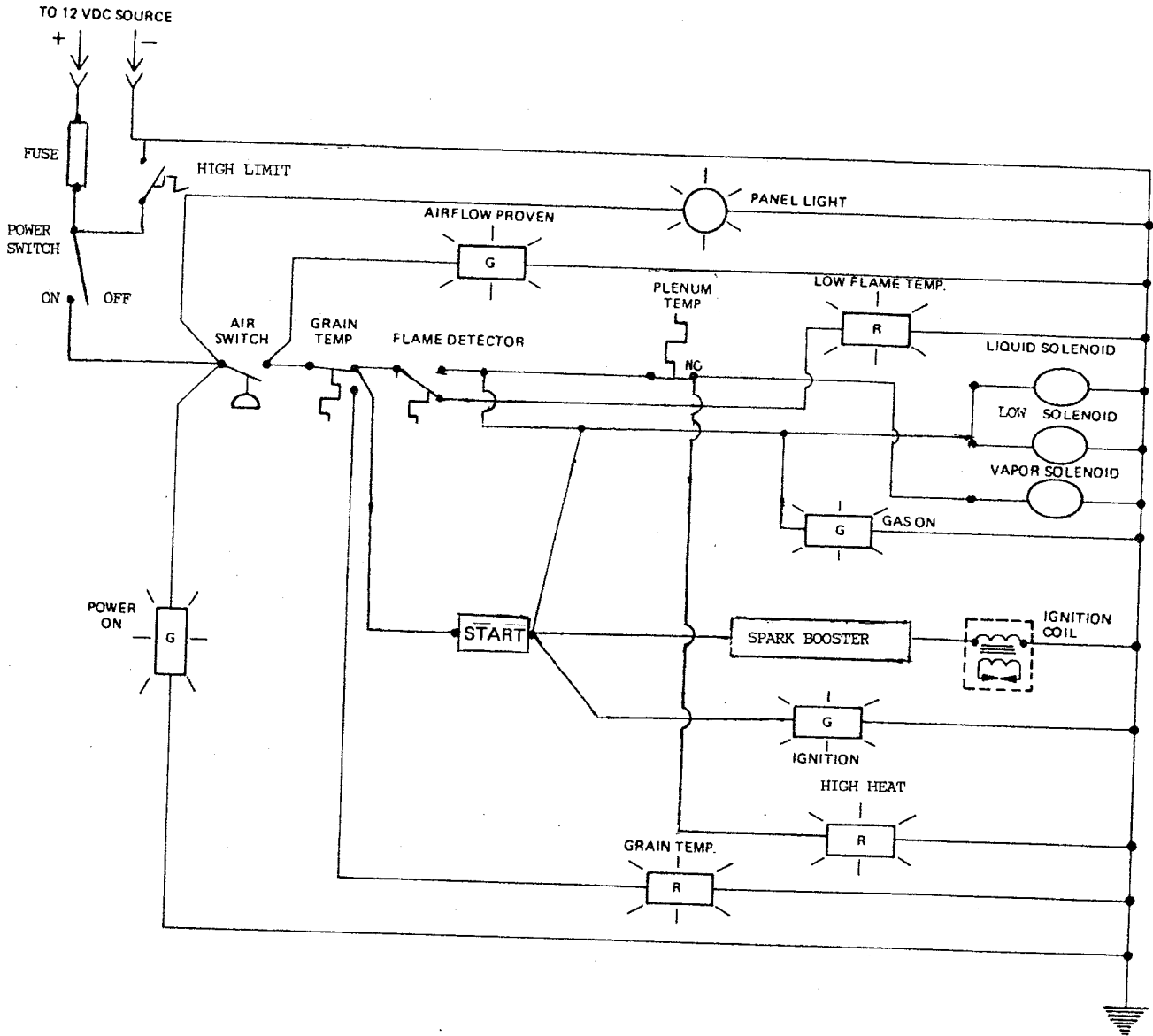

## SIDE MOUNT DRIVE SCHEMATIC

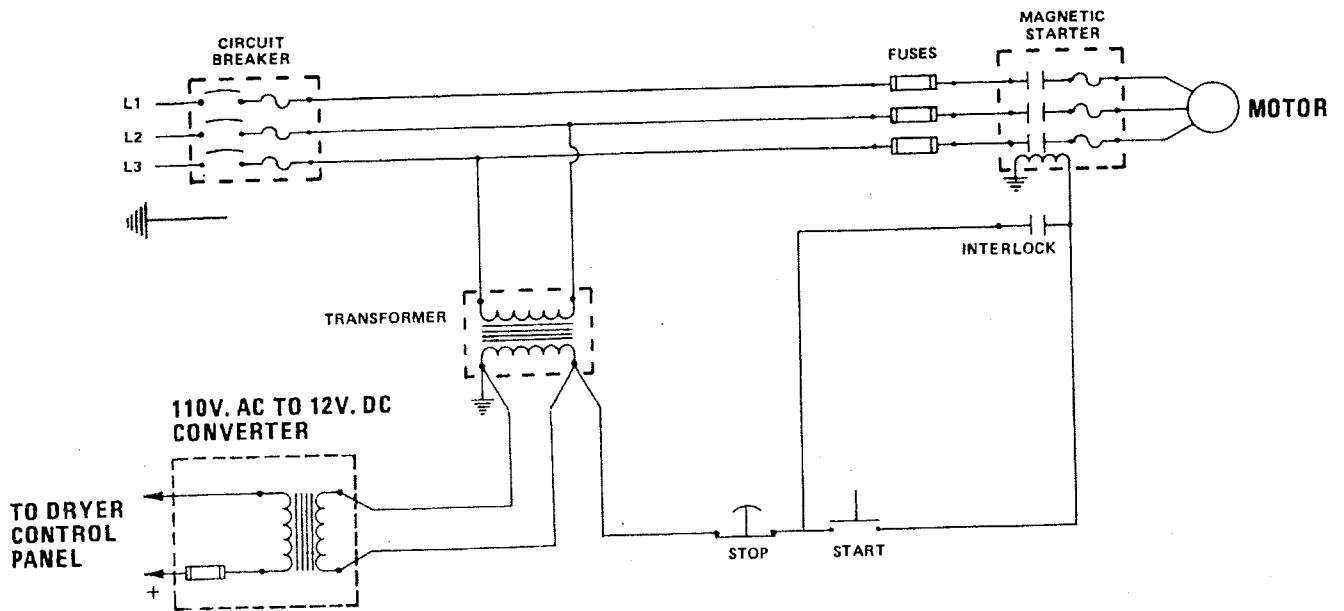

## SIDE MOUNT DRIVE SEQUENCE OF OPERATION

With the circuit breaker connected to the proper source and in the "on" position the circuit is completed to the magnetic starter and to the stepdown voltage transformer. Voltage to the magnetic starter controls is now reduced to 110 VAC. Voltage to the burner control panel is fed through the 110 VAC to 12 VDC converter so that the burner controls operate on 12 volts.

Pushing the motor start button completes the circuit through the holding coil on the magnetic starter causing its contacts to close thus supplying power to start and run the motor.

When the starter contacts close, the contacts on the interlock also close which completes the circuit bypassing the start button. The start button may be released.

## SIDE MOUNT WIRING DIAGRAM

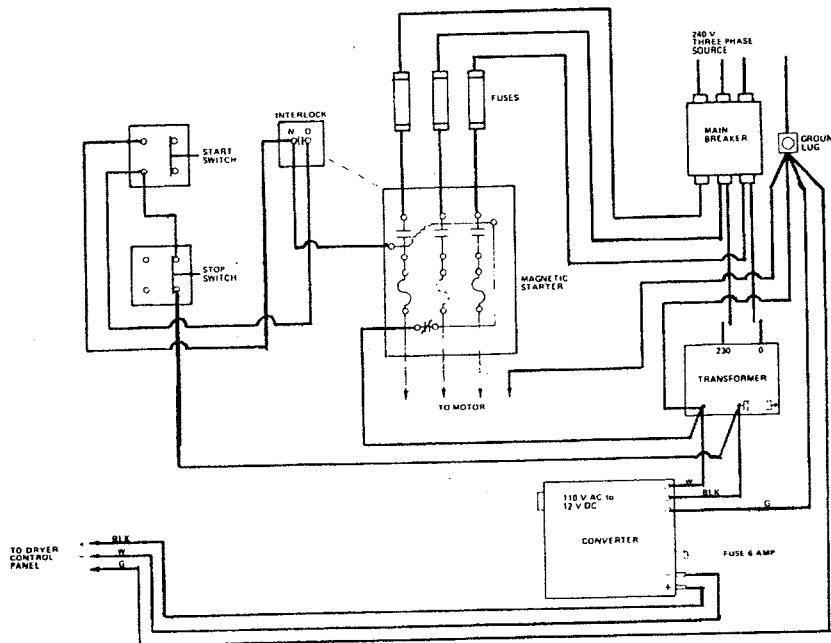



## TROUBLE SHOOTING



CAUTION: Caution should be exercised when checking control panel. Use volt meter or test light.

### Problem A. BURNER WILL NOT LIGHT

#### Probable Cause

1. Are both tank and dryer fuel valves open?
2. Is power supply properly connected? (Green "power on" light should be on with the power switch in the on position.) Must have the red battery clip connected to the hot (+) side of the battery and the black clip connected to the ground (-) side of the battery. Refer to page 19 for proper battery connections.
3. Check that circuit breaker switch didn't trip.
4. Is grain temperature above control setting? (Red grain temperature light will be on if control setting is exceeded.)
5. Check to see that both solenoid gas valves are opening. With fan at operating speed, or with air switch jumpered, flip the "power" switch to "on" and watch pressure gauge. If valves open there should be a pressure reading.
6. Air switch not closing (Airflow light not on). Remove and clean or replace air switch tube.
7. Check for plugged orifice.
8. Possible loose wire connection.
9. Gas pressure too low. May require up to 5 psi. for ignition with propane burner.
10. Gas pressure too high. 30 psi. is near maximum for ignition with the propane burner. If gas pressures above 30 psi. are encountered, check the 5/64" diameter burner parts for signs of plugging and clean them out if necessary.
11. System improperly grounded. Check lead wire connections at terminal block.
12. Check plug for spark. If no spark check the following after disconnecting power to the system.
  - a. Check spark gap. Gap should be  $3/32" \pm 1/32"$ . If plug is carboned at the points, clean and replace after checking gap.
  - b. Check high voltage lead wire for cracks or breaks, and replace if necessary.
  - c. Check that the high voltage lead wire is not too close to a metal surface to insure that arcing will not occur at any point other than across the high voltage electrode at the ignitor.
13. Check fuel strainer.
14. Check fuse.

Problem B. BURNER LIGHTS BUT PRESSURE WILL NOT EXCEED 5 TO 6 POUNDS AND/OR HAS EXCESSIVE FLUTTERING.

Probable Cause

1. Vapor solenoid valve malfunctioning.

Solution:

Disassemble solenoid valve body and remove diaphragm. If diaphragm is oily or dirty, wipe clean and replace. If diaphragm is ruptured replace with new diaphragm.

2. Pressure regulator malfunctioning.

Problem C. BURNER IGNITES BUT GOES OUT DURING OPERATION.

Probable Cause

1. Plenum control set below plenum temperature. (Red plenum temperature light will be on.)
2. Grain temperature exceeds control setting. (Red grain temperature light will be on.)
3. Electrical connections may be loose.
4. Worn insulation or wet wires may be grounding out.
5. Excess flow valve at fuel tank may be closing.
6. Check for stoppage in air switch tube. (Green airflow light not on.) (Remove tube from switch and blow out dirt.)
7. The flame detector bulb is not sensing flame at the burner. (Red low flame light on) The flame detector must sense enough heat from the flame to close its contacts before the delay timer times out or the gas valves will close. If the flame detector is not closing it will be necessary to adjust the sensor bulb mounted to the burner so that it picks up more heat from the flame. To do this adjust bulb so that it protrudes into the burner 3/8 to 1/2". Do not over-tighten the locking nut on the flame detector bulb.

Problem D. UNCONTROLLABLE HEAT.

Probable Cause

1. Cracked Vaporizer.
2. Ruptured gas line.

Problem E. TRASH OR GRAIN FIRE.

Probable Cause

1. Excessive plenum temperature.
2. Trash build-up in plenum.
3. Poor circulation due to agitator being out of operation or adjustment.
4. Ruptured gas line or vaporizer.
5. Improper burner and baffle adjustment.

Solution:

- a. Shut off gas supply.
- b. Disengage fan clutch and continue to circulate grain in machine or empty machine if necessary.

Problem F. GAS WILL NOT SHUT OFF IMMEDIATELY WHEN POWER IS SHUT OFF.

Probable Cause

1. Perforated diaphragm in vapor solenoid valve.
2. Plunger upside down in vapor solenoid valve.
3. Lack of diaphragm in vapor solenoid valve.

Problem G. AGITATOR DRIVE CHAIN OFF



DANGER Do not open inspection door or enter machine when in operation.

Probable Cause

1. Roller stuck - seized bearing - may be flat on one side.
2. Too much horizontal play between agitator race and rollers.
3. Agitator drive sprocket out of line.
4. Too slack a chain.
5. Excess feeding of loading auger causing grain level to rise above agitator. (Close grain flow regulator slightly to reduce feed rate.)

Problem H. AUGER STOPPAGE

Probable Cause

1. Slack belt.
2. Block of wood or rock lodged between auger flight and housing.
3. Extremely wet grain standing over night.
4. Bottom auger bearing frozen.

Problem I. EXCESSIVE DRYING TIME

Probable Cause

1. Too low plenum temperature for conditions.
2. Inaccurate plenum temperature gauge.
3. Poor circulation of grain.
4. Dirty or trashy grain.
5. Hard to dry grain variety (Thick seed coat)
6. Incorrect Fan Speed.
7. Adverse weather conditions.
8. Re-circulation of exhaust air from dryer back into plenum.

## Problem J. POOR GRAIN CIRCULATION

### Probable Cause

1. Fan speed above that recommended.
2. Build up of foreign material, especially in bottom section of dryer.
3. Agitator not operating.

### INDICATOR LIGHT CHECK OUT PROCEDURE

The indicator lights on the dryer's switch panel have been put there to aid in the operation of the dryer. These lights should be checked periodically to assure that they are operating.

With the fan operating at the recommended RPM, the electrical power source properly connected, the gas supply turned on, and all the gas valves open complete the following test.

Turn the power switch on and see that the green "power on" and "air flow proven" lights come on. Also see that the red "low flame temperature" light comes on.

Push the start button, the ignition light and the gas on light will come on. Hold start button until the red low flame light goes off and then release.

Panel should now register the normal operating condition, i.e. green "power, airflow and gas on" lights on. There will be no red lights on unless the High Heat thermostat is above the plenum temperature, the the High Heat Red light will be on.

Turn grain temperature thermostat below indicated grain temperature. The red grain temperature light will come on and the gas on light should go off. After approximately 20 sec. the low flame light will come on.

**ASSEMBLY DRAWINGS  
AND  
PARTS LISTS**

POWER UNIT ASSEMBLY

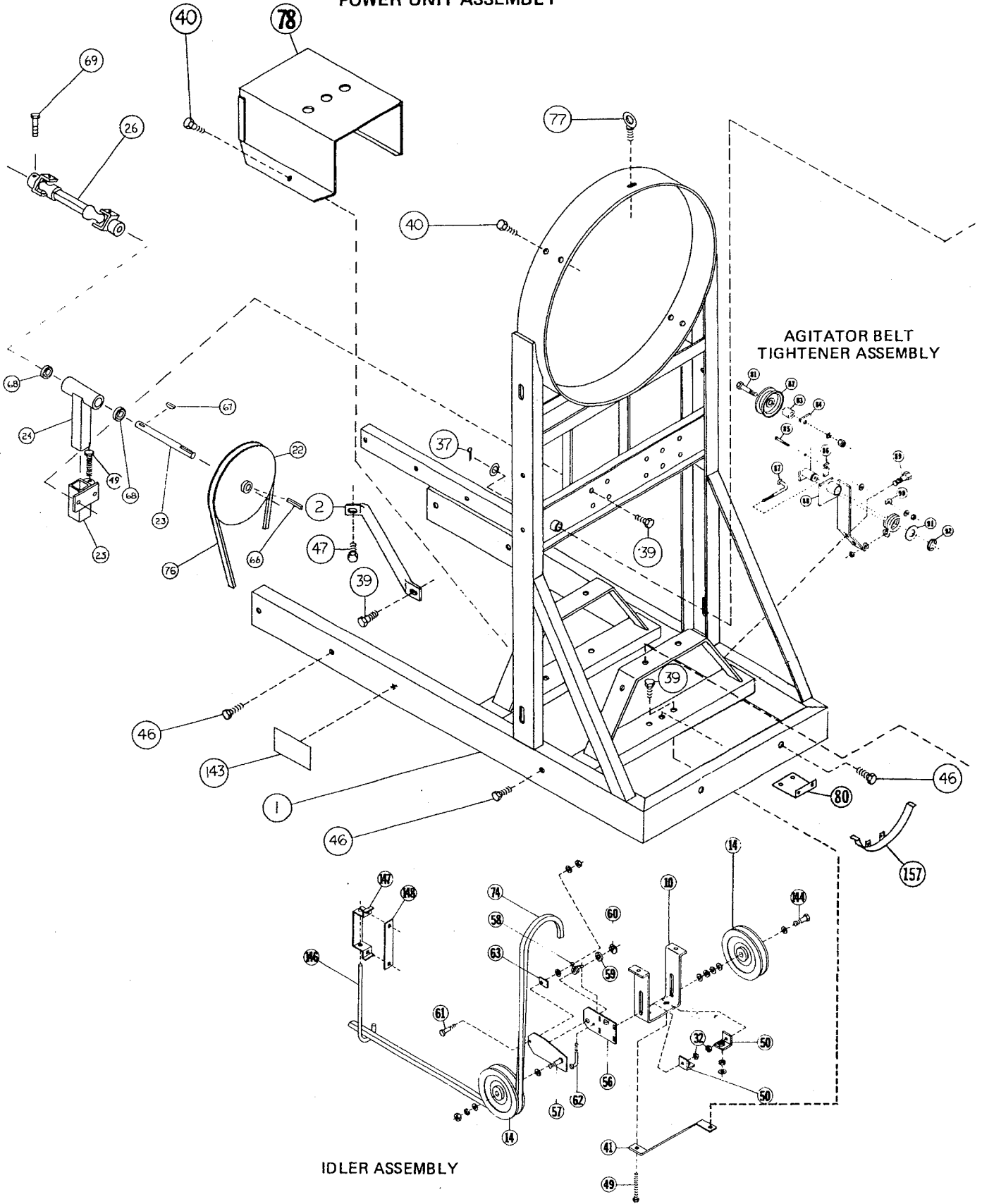

# POWER UNIT ASSEMBLY

## FAN CLUTCH ASSEMBLY

## FAN ASSEMBLY

## I.O. ASSEMBLY

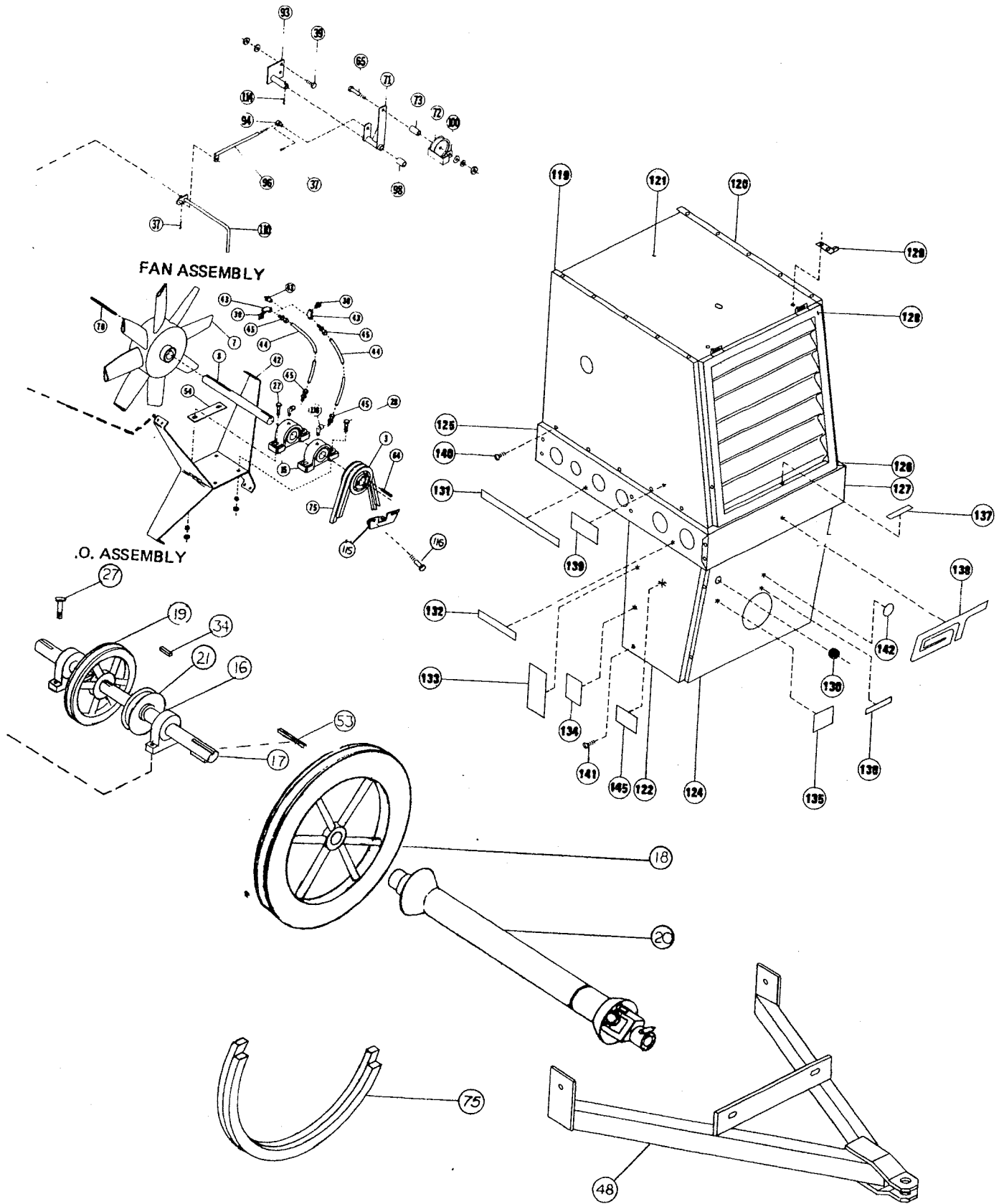

**POWER UNIT ASSEMBLY**

REF. NO.	PART NO.	NO. REQ'D.	DESCRIPTION
1	D52016	1	Frame Power
2	D52021	2	Brace
3	76006	1	Sheave, Fan Driven (2B 5.6) 545XL
3	76047	1	Sheave, Fan Driven (2B 6.0) 645XL
	76007	1	Hub, Fan Driven Sheave
	76007	1	Fan, 545XL
7	D52075A	1	Fan, 645XL
7	D52076A	1	Hub, 1½"
	76067	1	Shaft, Fan
8	D52081	1	Support, Idler
10	D32010	1	Sheave, Idler
14	D22142	2	Sheave, Cast (UK)
14	D22145	2	Bearing, 1½" Pillow Block w/Shim & Adapter
15	D22090	2	Bearing, 1½" Pillow Block
16	D22097	2	Shaft, Power
17	D22161S	1	Sheave, Fan Drive (2B 24)
18	D22170	1	Sheave, Auger Drive (1C9)
19	D22180	1	Tumbler, PTO Drive (See page 33 for parts)
20	D52194	1	Sheave, Agitator Drive (1B4)
21	D22780	1	Sheave, Agitator Driven (1B16)
22	D22790	1	Jackshaft, Agitator
23	D22850	1	Housing, Agitator Bearing w/o Bearings
24	D22861	1	Agitator Bearing Housing w/Bearings
24	D22866	1	Mount, Agitator Bearing Housing
25	D22871	1	Tumbler, Agitator Drive (See page 32 for parts)
26	D58250	1	Capscrew, ½" x 2"
27	71106	6	Capscrew, ½" x 2¼"
28	71107	2	Machine Screw - ¼" — 20 x ½" Slotted Head
29	71823	28	Machine Bushing, 7/8"
31	72591	4	Nut, 5/8" Jam
32	72255	2	Key, 3/8" sq. x 1½" lg.
34	73411	2	Pin, Cotter 1/8" x 1¼"
37	73534	2	Capscrew, 5/8" x 1½"
38	71129	3	Capscrew, ½" x 1"
39	71102	11	Capscrew, 3/8" x 1¼"
40	71053	12	Brace, Idler Support
41	D52632	1	Brace, Fan Shaft Support
42	D52691	1	Zerk, 1/8" NPT Female Grease
43	73332	2	Grease Line, Fan Bearing
44	D52930	2	Compression Fitting, 3/16" Tube to 1/8 N.P.T.
45	73109	4	Capscrew, ½" x 3½"
46	71111	8	Capscrew, ½" x 4½"
47	71113	1	Hitch
48	D52461	1	Capscrew, ½" x 5" Full Thread
49	71957	3	Tightener
50	D22260	2	Key 3/8" sq. x 4¼"
53	73415	1	Spacer
54	D22099	As Req'd.	Fixed Member, Spring Loaded Idler
56	D22801	1	Pivot Member, Spring Loaded Idler
57	D22812	1	Spring
58	73308	1	Washer
59	D22820	1	Ring, Retaining
60	73231	1	Capscrew, 5/16" x 1¼"
61	71028	1	L-Bolt
62	D22840	1	Stop, Pivot
63	D22830	1	Key, 3/8" x 3/8" x 1½"
64	73411	1	Capscrew, ½" x 3"
65	71110	3	Key, ¼" sq. x 1¼"
66	73400	1	Key, 808 Woodruff
67	42-18282	1	Bearing, Agitator Jackshaft
68	42-16334	2	Capscrew, 3/8" x 2½" H.T.
69	73508	1	Key, 3/8" sq. x 6-3/8"
70	73420	1	Arm, Fan Clutch Idler
71	D52161	1	Pulley, Idler
72	42-16336	1	Spacer
73	D32220	1	Belt, Auger Drive (C255)
74	D52620	1	Belt, Fan Drive (B148)
75	D52271	2	



**POWER UNIT ASSEMBLY**

REF. NO.	PART NO.	NO. REQ'D.	DESCRIPTION
76	42-16125	1	Belt, Agitator Drive (B85)
77	71941	1	Eyebolt, 1/2" x 1 1/2"
78	D22652	1	Guard, Power Shaft
	D5291	1	Agitator Idler Assembly (includes items 81-92 inclusive)
79	71051	1	Capscrew, 3/8" x 3/4"
80	D57135	1	Belt Retainer, Lower Fan
81	71109	1	Capscrew, 1/2" x 2 3/4"
82	42-16335	1	Pulley, Idler
83	D22927	1	Spacer, Idler
84	D22926	1	Arm, Idler
85	71029	1	Capscrew, 5/16" x 1 1/2"
86	D22830	1	Stop, Pivot
87	D22840	1	L-Bolt
88	D52926	1	Mount, Idler
89	71053	2	Capscrew, 3/8" 1 1/4"
90	73308	1	Spring
91	D22820	1	Washer
92	73231	1	Ring, Retainer
93	D52171	1	Pivot Clutch Idler
94	D32270	1	Pin, Fan Clutch Swivel
96	D52235	1	Arm, Link
98	D32040	1	Tube, Belt Retaining
100	D32260	1	Guide, Fan Clutch Belt
110	D52152	1	Handle, Fan Clutch
114	73536	1	Pin, Cotter 1/8" x 1 3/4"
115	D32250	1	Brake, Fan Sheave
116	71061	2	Capscrew, 3/8" x 3 1/2"
117	72364	1	Nut, 3/8" Spot Weld
118	73048	1	Adapter, Grease Line, 1/4" x 28 Male to 1/8" N.P.T. Female x 90°
119	D52663	1	Panel, Right Fan Guard
120	D52671	1	Panel, Left Fan Guard
121	D52042	1	Panel, Top Fan Guard
122	D52885	1	Panel, Right Belt Guard
123	D52880	1	Panel, Left Belt Guard
124	D52062	1	Guard, Front Belt
125	D52893	1	Wrapper, Right Power Frame - (LP Gas)
125	D52898	1	Wrapper, Right Power Frame - (NP)
126	D52130	1	Wrapper, Left Power Frame
127	D52900	1	Wrapper, Front Power Frame
128	D52052	1	Grill
129	D32120	2	Grill Hinge Strap
130	73278	1	Grommet
131	73957	1	Decal, Valve
132	73958	1	Decal, Plenum & Grain Temperature
133	73682	1	Decal, Caution Be a Safe Operator
134	73661	1	Decal, Danger LP Gas Supply
135	73668	1	Decal, Caution Fan Clutch
136	73607	1	Decal, Max. PTO Speed 540 RPM
137	73619	1	Decal, Max. Fan Speed 2250 RPM
138	73949	1	Decal, GT Logo
139	74712	1	Decal, 545XL
140	71823	42	1/4" x 20 x 1/2" Slotted HD Machine Screw
141	71825	6	1/4" x 20 x 3/4" Slotted HD Machine Screw
143	73833	1	Decal, Danger: Keep Hands & Feet Away
144	71135	1	Capscrew, 5/8" x 3"
145	73981	1	Decal, DANGER - Electrocution
146	D21420	1	Rod, Auger Belt Guild
147	D21430	1	Bracket, Auger Belt Guide Rod
148	D21440	1	Clamp, Auger Guide Bracket
157	D57325	1	Guide, Fan Belt

Note: For nuts, washers and lockwashers, see page 63

**AGITATOR DRIVE TUMBLER  
D58250**

REF. NO.	PART NO.	NO.REQ'D	DESCRIPTION
1	75519	2	U-Joint Kit
2	42-16182	1	Yoke w/Keyway
3	73596	1	Yoke w/Pin Hole

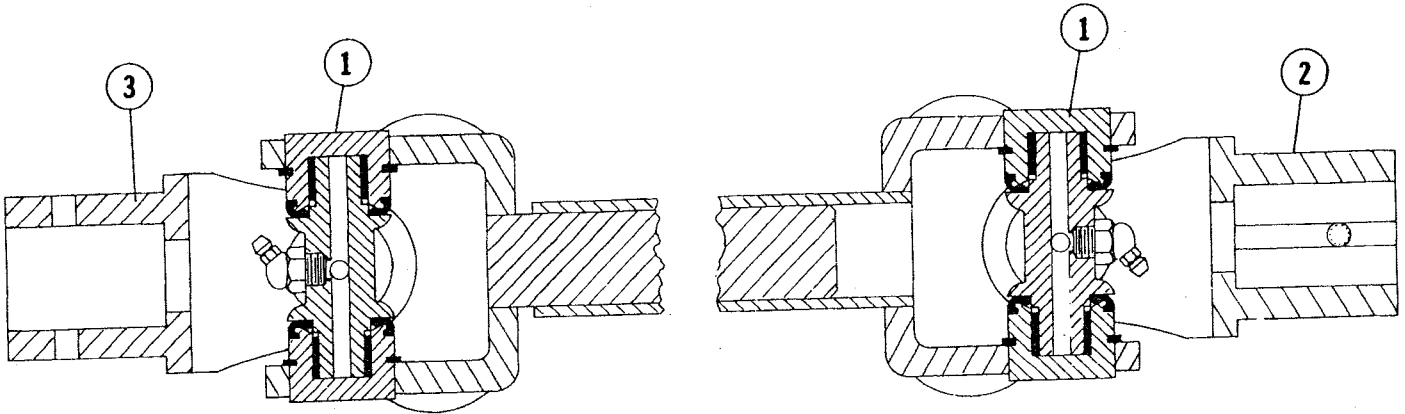

**LOADING AUGER TUMBLER  
D59343**

REF. NO.	PART NO.	NO.REQ'D	DESCRIPTION
1	75519	2	U-Joint Kit
2	42-16182	2	Yoke w/Keyway

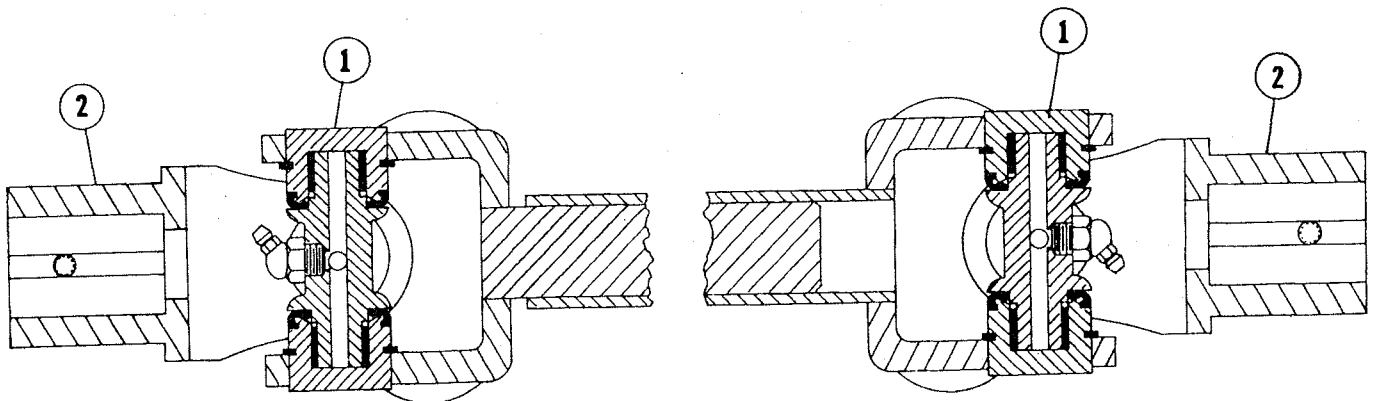

Note: For nuts, washers and lockwashers, see page 63.

**PTO TUMBLER SHAFT  
D52194  
TUMBLER**

REF. NO.	PART NO.	NO. REQ'D.	DESCRIPTION
1	73299	2	Yoke w/Spline
2	73299		1-3/8 Sp Yoke wchd
3	73298	2	U-Joint Kit
4	75514	2	Nylon Bearing Kit
5	75516	1	Safety Shield, Outer
6	75515	1	Safety Shield, Inner

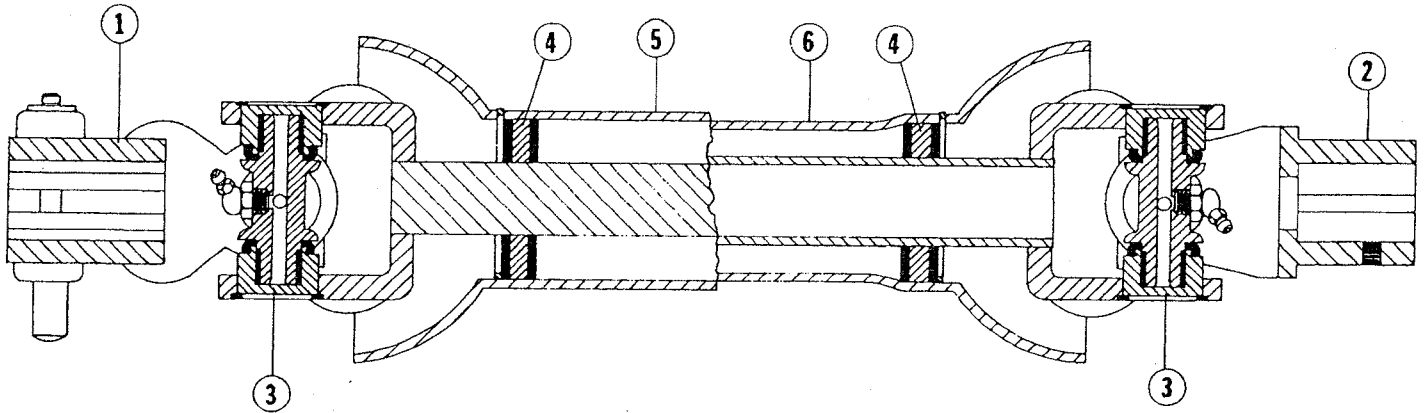

# BURNER ASSEMBLY

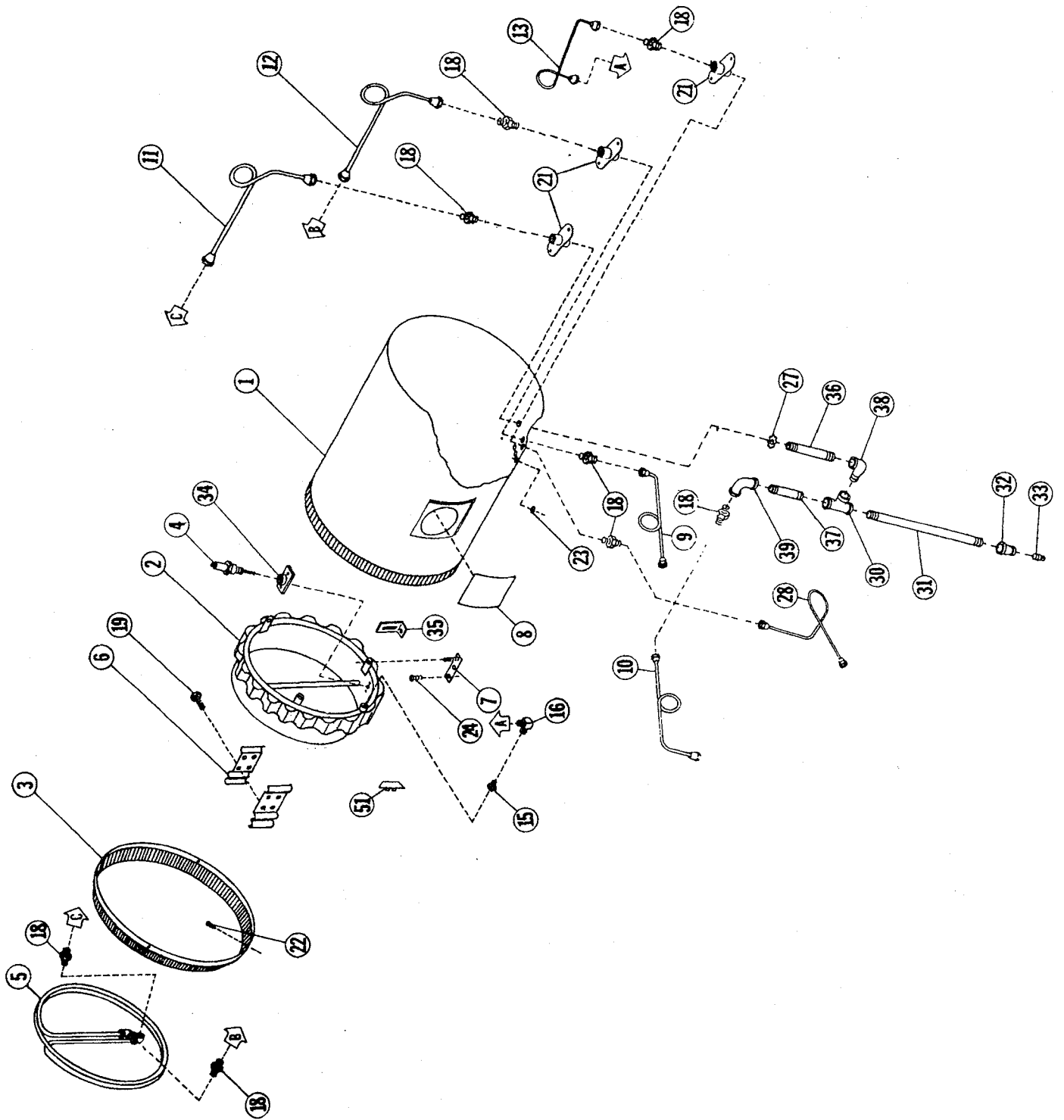

BURNER ASSEMBLY

REF. NO.	PART NO.	NO.REQ'D.	DESCRIPTION
1	D52295	1	Tube, Burner (Propane)
1	D52960	1	Tube, Burner (Natural Gas)
2	D52303	1	Burner, Ring (Propane)
2	D52305	1	Burner, Ring (Natural Gas)
3	D52520*	1	Ring, Flame Deflector
4	D22320	1	Spark Plug
5	57001279*	1	Vaporizer, Ring
6	57001242*	2	Bracket, Vaporizer
7	57001240	3	Mount, Burner
8	D22462	1	Window, Plexiglass
9	D52110	1	Tube, Outside Liquid to Vapor
9	D32331*	1	Tube, Outside Liquid to Vapor (CSA)
10	D32312*	1	Tube, Outside Vapor to Plumb.
11	57001268*	1	Tube, Inside Vapor
12	57001267*	1	Tube, Inside Liquid
13	D52374*	1	Tube, Inside Vapor to Burner
15	D52404	1	Orifice - LP
16	D32301	1	Holder, Orifice
18	73086*	8	Adapter, 1/2" P. to 1/2" T. Union
19	71028*	4	Capscrew, 5/16" x 1 1/4" Hex
21	D37330	3	Coupler, Union Brkt.
22	71942*	4	Screw, No. 14 x 3/4" Metal
23	73270	2	Grommet, 3/8" I.D. Rubber
24	71825	8	Machine Screw, 1/4" - 20 x 3/4" SL HD
25	72035	2	Screw, No. 8 x 1/4" Metal
27	77100*	1	Nut, Conduit
28	D52121*	1	Tube, Outside, Vapor to Burner
29	72790*	1	Nipple, 1/2" Close
30	72947*	1	Tee, 1/2" x 1/2" x 1/2" N.P.T.
31	72928*	1	Nipple, 1/2" x 13"
32	72910*	1	Reducer, 1/2" x 1/4"
33	72633*	1	Plug, 1/4" N.P.T. Pipe
34	57001241	1	Mount, Spark Plug
34	D55520	1	Mount, Spark Plug (NG)
35	D32130	1	Bracket, Flame Detector Bulb Mount
36	72797*	1	Nipple, 1/2" x 4 1/2" XH
37	72793*	1	Nipple, 1/2" x 2 1/2" XH
38	72946*	1	Elbow, 1/2" x 900 St.
39	72945*	1	Elbow, 1/2" x 900
51	D32370	1	Shield, Burner (Propane)
51	D55510	1	Shield, Burner (NG)

NOTE: \*Propane Burners Only

Note: For nuts, washers and lockwashers, see page 63

PROPANE CONTROL CABINET ASSEMBLY  
QUIET FAN - NON MICRO

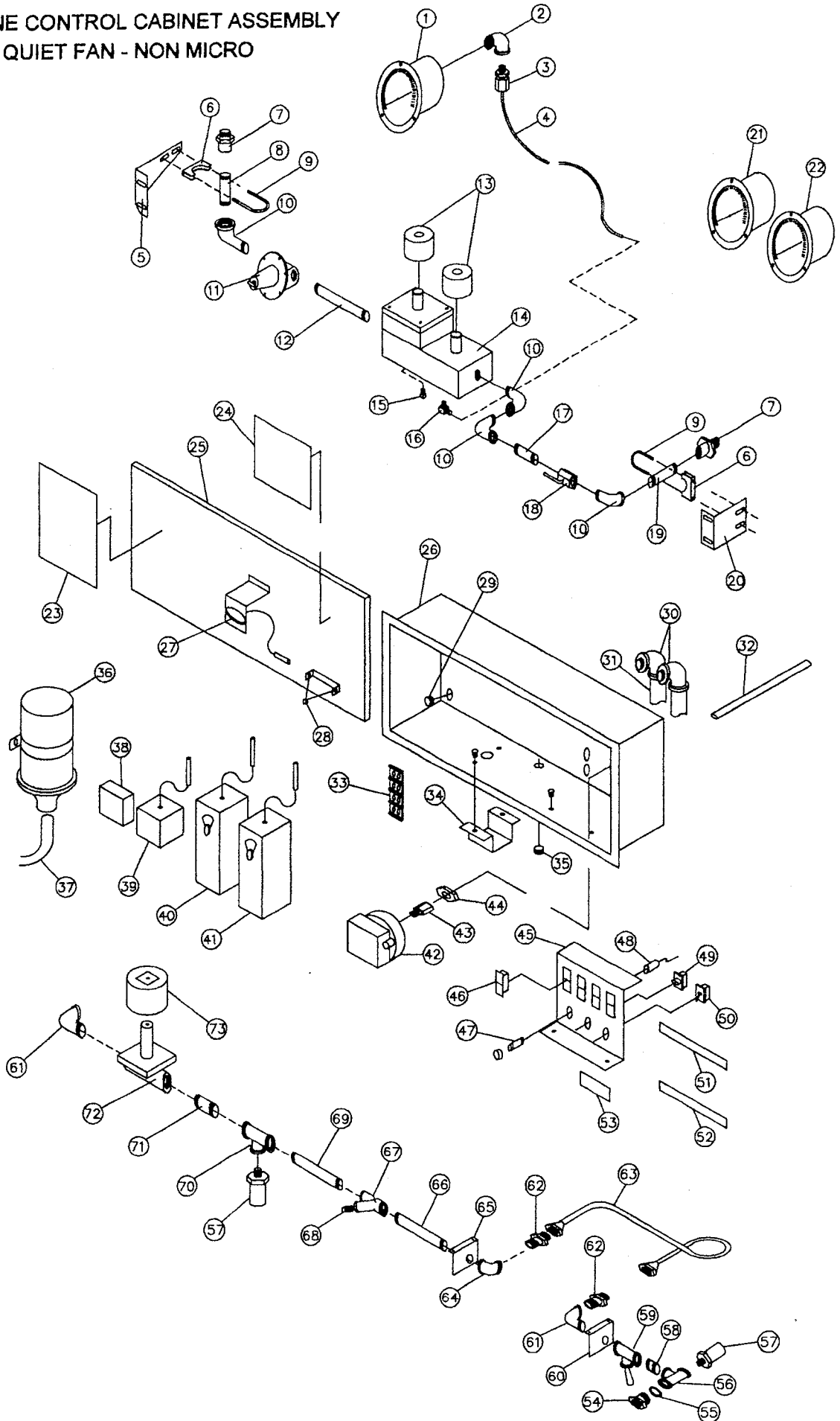

PROPANE CONTROL CABINET ASSEMBLY - QUIET FAN - NON MICRO

REF. NO.	PART NO.	NO.REQ'D.	DESCRIPTION
1	D25102	1	Gauge, Pressure
2	72841	1	Elbow, 1/4" x 90°
3	73110	1	Connector, 1/4" Tee to 1/4" Pipe
4	D55310	1	Line, Pressure Gauge
5	D25632	1	Bracket, Rear Plumbing
6	D25610	2	Clamp, 1/2" Saddle
7	73071	2	Connector, 1/2" Tee to 1/2" Pipe
8	72792	1	Nipple, 1/2" x 2"
9	71987	2	U-Bolt
10	72858	4	Elbow, 1/2" Street
11	D25191	1	Regulator, 1/2" Pressure
12	72799	1	Nipple, 1/2" x 6" SCD80
13	77575	2	Coil, Solenoid Block
14	77587	1	Valve, 1/2" Solenoid Block
15	73146	1	Plug, 1/4" NPP Brass
16	73047	1	Elbow, 90° Brass, 1/4" Tee to 1/4" M.N.P.T.
17	72791	1	Nipple, 1/2" x 1 1/2"
18	74123	1	Valve, Ball
19	72793	1	Nipple, 1/2" x 2 1/2"
20	D25620	1	Bracket, Front Plumbing
21	D24033	1	Thermometer, Plenum
22	D24123	1	Thermometer, Grain
23	74714	1	Decal, Operating Instructions
24	74715	1	Decal, Wiring Diagram
25	D25511	1	Door, Cabinet
26	D25863	1	Cabinet
27	73223	1	Light, Utility 12 volt only
28	73270	2	Grommet, 3/8" I.D. Rubber
29	73271	2	Grommet, 1/4" I.D. Rubber
30	73159	4	Connector, 3/8" x 90 Degree
31	D55260	2	Conduit, 25" Long
32	D52321	1	Tube, Air Switch
33	77230	1	Block, Terminal
34	D25252	1	Bracket, Solenoid
35	73278	1	Grommet, 5/8" I.D. Rubber
36	77228	1	Coil
	77229	1	Bracket, Coil
37	77540	1	Wire, Spark Plug
38	77384	1	Booster, Spark
39	D25161	1	Flame Detector
40	D25770	1	Switch, Plenum
	77393	1	Knob, Switch
41	K25231	1	Thermostat, Grain Temperature
42	K25030	1	Air Switch
43	73110	1	Connector, 1/4" Tee to 1/4" Pipe
44	72279	1	Nut, 1" N.F. Hex Ham
45	D25212	1	Bracket, Switch
46	77162	4	Light, Indicator
47	77143	1	Fuse, 10 Amp

PROPANE CONTROL CABINET ASSEMBLY - QUIET FAN - NON MICRO

REF. NO.	PART NO.	NO.REQ'D.	DESCRIPTION
48	D25170	1	Holder, In-Line Fuse
49	D25140	1	Switch, Push to start
50	D25130	1	Switch, On - Off
51	74530	1	Decal, Green Indicator
52	74615	1	Decal, Red Indicator
53	74725	1	Decal, Push to Start
54	90037	1	Connector, 1/2" Hose to 3/8" N.P.T.
55	72595	1	Washer
56	72956	1	Tee, 3/8"
57	D25240	2	Valve, 1/4" N.P.T. Relief
58	72780	1	Nipple, 3/8" Close
	72890	2	Bushing, 3/8" x 1/4" Reducer
59	D25120	1	Valve, 3/8" N.P.T. Quick Acting
60	D25275	1	Bracket
61	72944	2	Elbow, 3/8" N.P.T. Street
62	73085	2	Connector, 1/2" tube to 3/8"
63	D57242	1	Tube, Liquid Inlet
64	72948	1	Elbow, 3/8" N.P.T.
65	D25272	1	Bracket, Plumbing
66	72784	2	Nipple, 3/8" N.P.T. x 3" X.H.
67	D25280	1	Strainer, 3/8" N.P.T.
68	72653	1	Plug, 3/8" N.P.T. Pipe
69	72787	1	Nipple, 3/8" x 4 1/2"
70	72956	1	Tee, 3/8" N.P.T.
	72980	1	Bushing, 3/8" x 1/4" Red
71	72781	1	Nipple, 3/8" N.P.T. x 1 1/2" X.H.
72	77640	1	Body, 3/8" N.P.T. Solenoid Valve
73	77641	1	Coil, Solenoid Valve 12 volt

Note: For nuts, washers and lockwashers, see page 63.



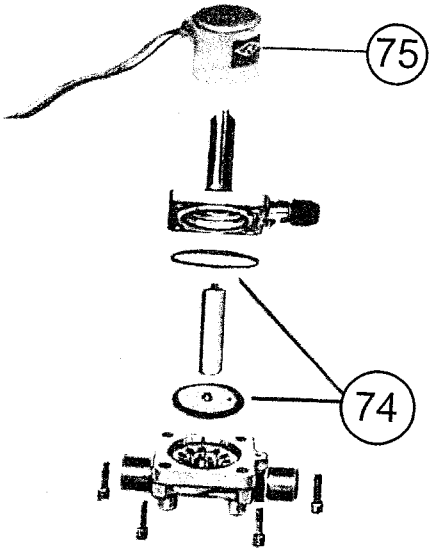

### SOLENOID VALVE ASSEMBLY

REF. NO.	PART NO.	DESCRIPTION
74	77643	Kit, 3/8" Solenoid Valve Diaphragm Repair
74	77643	Kit, 1/2" Solenoid Valve Diaphragm Repair
75	77641	Coil, 12 Volt Solenoid Valve, 27" Leads w/Forks

# BURNER ASSEMBLY

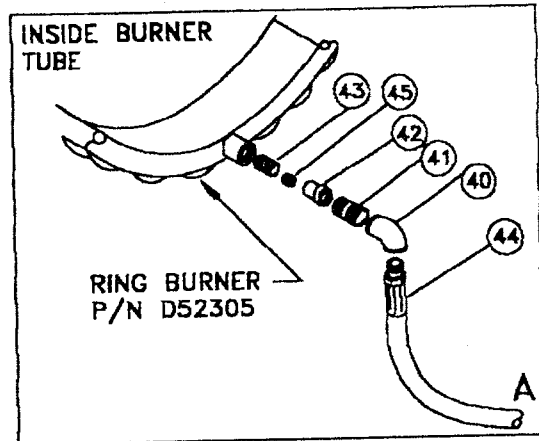
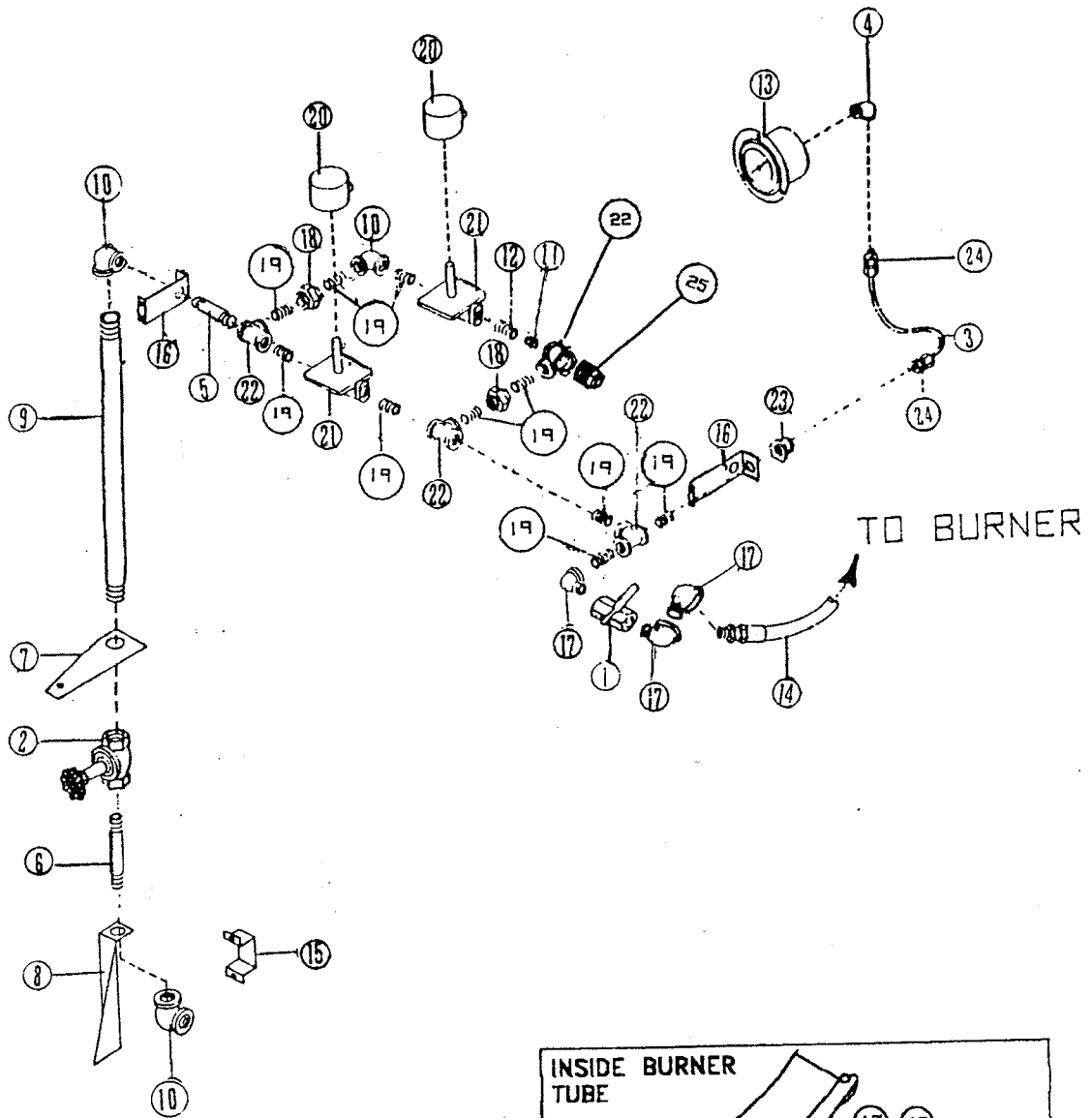

- |    |        |                       |
|----|--------|-----------------------|
| 40 | 72845  | 1 x 90 EL             |
| 41 | 72700  | 1 CLOSE NIPPLE        |
| 42 | 72904  | 3/4 X 1 BELL REDUCER  |
| 43 | D25895 | NIPP[E, ORIFICE       |
| 44 | D52441 | 1 X 32 HOSE           |
| 45 | D52413 | ORIFICE 3/8 NG .5 NPT |

## 545 NATURAL GAS PLUMBING

REF. NO.	PART NO.	NO. REQ'D	DESCRIPTION
1	D55650	1	Valve, 1" Ball
2	73185	1	Valve, 1" Gate
3	D25305	1	Line, Pressure Gauge
4	72841	1	Elbow, 1/4" NPT x 900
5	72705	1	Nipple, 1" x 3 1/2"
6	72712	1	Nipple, 1" x 7"
7	D52950	1	Bracket, Lwr Plumbing
8	D32940	1	Bracket, Long Lwr Plumbing
9	72932	1	Nipple, 1" x 15"
10	72845	3	Elbow, 1" x 900
11	D52412	1	Orifice, NG Low Burn
12	D55895	1	Holder, Orifice
13	D25102	1	Gauge, Pressure
14	D52441	1	Hose, 1" x 32" NG
15	D52955	1	Clamp, Lwr NG Plumbing Brkt.
16	D52941	2	Bracket, NG Plumbing
17	72860	3	Elbow, 1" x 900 Street
18	72716	2	Union, 1" Pipe
19	72700	10	Nipple, 1" Close
20	77646	2	Coil, Solenoid Valve 12 VDC (27")
21	77645	2	Valve, 1" Solenoid
22	72916	4	Tee, 1" x 1" x 1"
23	72911	1	Reducer, 1" to 1/4" Bell
24	73110	2	Fitting, 1/4" NPT to 1/4 comp.
25	72713	1	1" Pipe Plug

Note: For nuts, washers and lockwashers, see page 63.

# FRAME ASSEMBLY

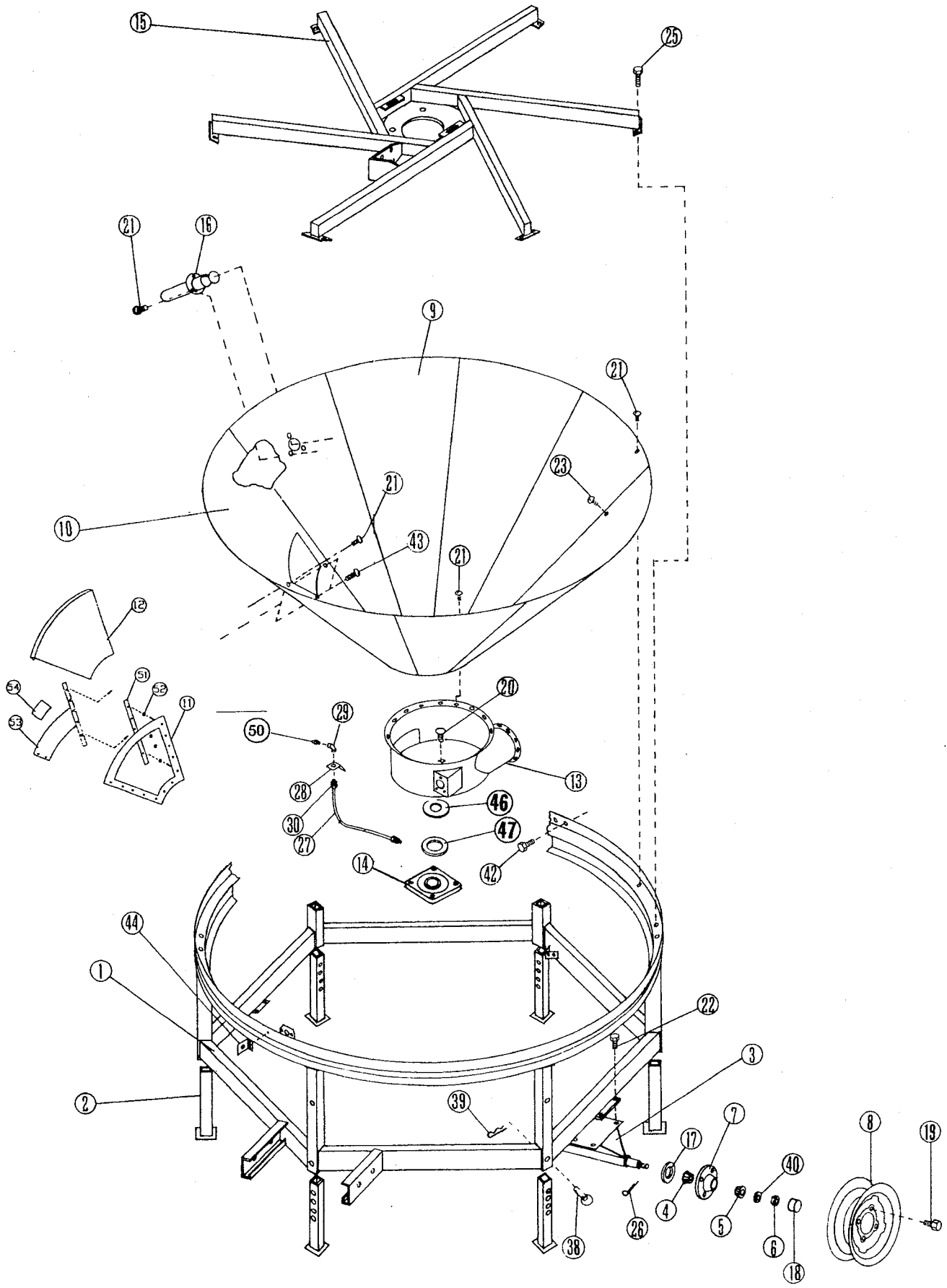

FRAME ASSEMBLY

REF. NO.	PART NO.	NO. REQ'D.	DESCRIPTION
1	D51015	1	Main Welded Frame Less Hitch
2	D21021	6	Jack
	D21022	6	Adjustable Jack (Optional)
3	D51032	2	Axle Assembly
4	42-110149	4	Inner Bearing
5	D21050	4	Outer Bearing
6	D21060	4	Nut
7	D21075	4	Hub with Bearing Cups
8	D21080	4	Wheel Rim 15"
	D21085	4	Tire, Tube & Rim (Mounted)
9	D51450	8	Bin Bottom Sheet (Perf. Coated)
9	D53311	8	Bin Bottom Sheet (Perf.)
10	D51460	1	Bin Bottom Sheet w/Access Hole (Perf. Coated)
10	D53322	1	Bin Bottom Sheet w/Access Hole (Perf.)
11	D21124	1	Access Door Frame
12	D21133	1	Access Door
13	D51144	1	Bin Bottom Well w/Boot
14	D21161H	1	Bottom Auger Bearing
15	D51173	1	Spider - 545XL
15	D71170	1	Spider - 645XL
16	D21182	1	Grain Sampler
17	D21190	4	Seal
18	D21200	4	Cap
19	42-16053	16	Lug Bolt
20	71329	4	Carriage Bolt 1/2" x 1/2"
21	71823	129	1/4" - 20 x 1/2" Slotted HD Machine Screw
22	71103	8	1/2" x 1/4" Capscrew
23	71822	150	1/4" - 20 x 3/8" Slotted HD Machine Screw
25	71053	20	3/8" x 1/4" Capscrew
26	73527	4	5/32" x 1/4" Cotter Pin
27	D51190	1	Line, Grease
28	D21220	1	Bracket, Line
29	72840	1	Elbow, 1/8"
30	73109	2	1/8" Compression Fittings
38	73586	6	Pin
39	73587	6	Clip
40	72474	4	3/4" Washer
42	71054	2	3/8" x 1 1/2" Capscrew
43	71825	2	1/4" - 20 x 3/4" Slotted Head Machine Screw
44	D22491	1	Bracket, Conduit
46	73289	1	Seal, 2" I.D. Neoprene Shaft
47	73290	1	Seal, 2.72" I.D. Neoprene Bearing
48	D51400	1	Bin Bottom Sheet (Solid)
50	42-16127	1	Zerk, 1/8" Grease
51	D21500	1	Track
52	72488	6	Washer, Hi-Lock
53	D21136	1	Bar, Safety
54	74716	1	Decal
	73287	1 ft.	Moulding, 20 Ga. Rubber

Note: For nuts, washers and lockwashers, see page 63.

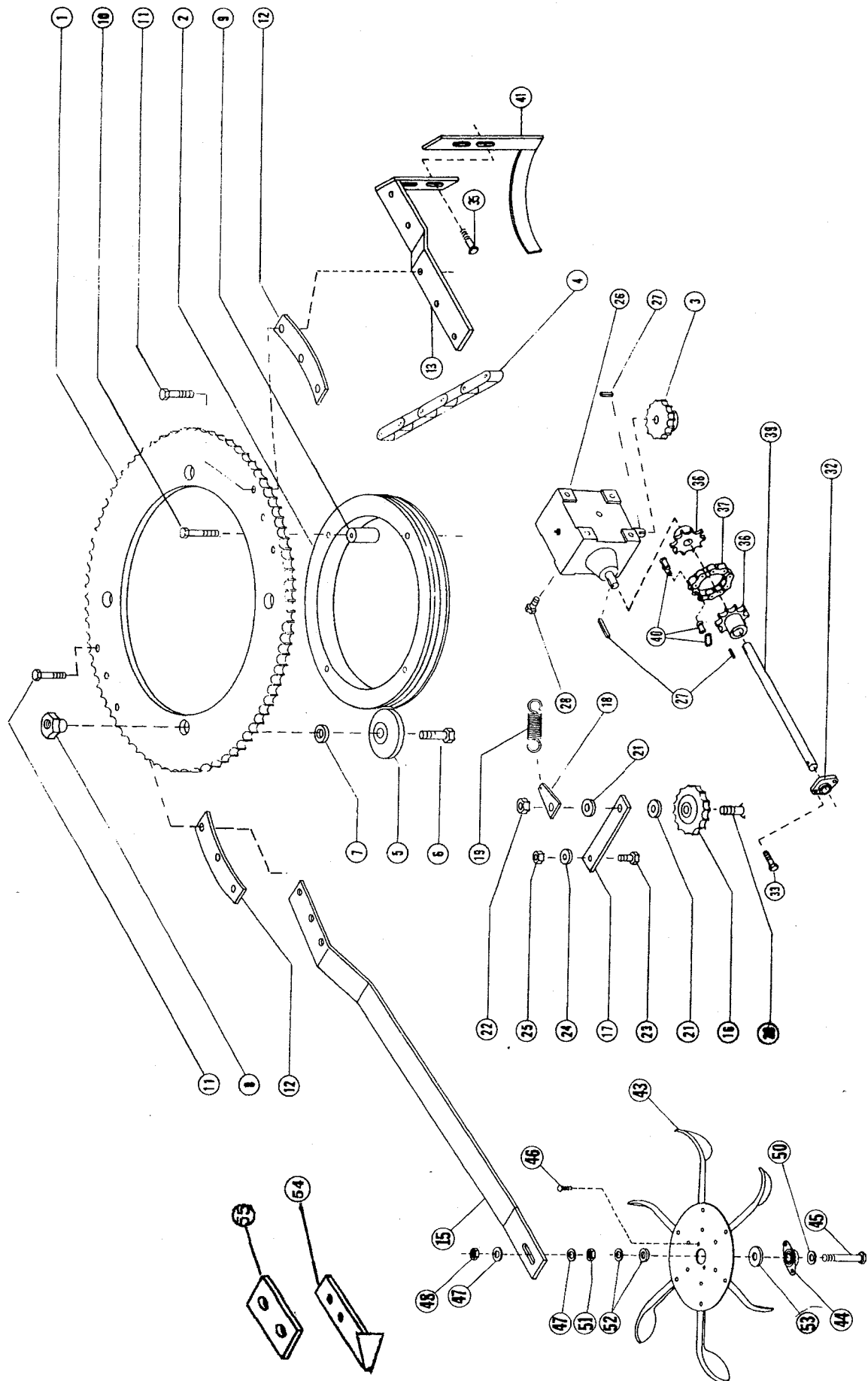

AGITATOR ASSEMBLY

REF. NO.	PART NO.	NO. REQ'D.	DESCRIPTION
1	D28033	1	Sprocket, No. 60, 112 Teeth
2	D28260	1	Race, Agitator
3	D28090	1	Sprocket, No. 60, 13 Teeth
4	D28141	1	Chain, No. 60 Roller 128 Pitches
5	D28161	4	Roller, Agitator w/Bearings
	A28000	4	Roller Brg. Kit
6	73521	4	Capscrew, 3/4" x 2 3/4" HT
7	72522	4	Washer
8	D28204	4	Nut, Cam
9	D28270	4	Spacer
10	73519	4	Capscrew, 7/16" x 5" HT
11	73504	6	Capscrew, 7/16" x 2 1/2" HT
12	D28082	4	Spacer, Agitator Arm
13	D58212	1	Arm, Horiz. Sect. Vertical Agitator (Standard)
15	D58064	1	Arm, Horizontal Agitator
16	D28172	1	Sprocket, No. 60 Idler 15 Teeth
17	D28181	1	Arm, Idler
18	D28280	1	Tab, Spring
19	D28190	1	Spring
20	71132	1	Capscrew, 5/8" x 2 1/4"
21	72413	2	Washer, 5/8"
22	72376	1	Nut, 5/8" Lock
23	71103	1	Capscrew, 1/2" x 1 1/4"
24	72412	1	Washer, 1/2"
25	72379	1	Nut, 1/2" Lock
26	D28241	1	Gearbox
27	73400	3	Key, 1/4" Square x 1 1/4" Lg.
28	71052	4	Capscrew, 3/8" x 1 1/2"
32	D28290	1	Bearing w/Collar
33	71029	2	Capscrew, 5/16" x 1 1/2"
35	71331	2	Bolt, 1/2" x 2" Carriage
36	D28330	2	Coupler Half, 60B 10 x 1"
37	D28331	1	Chain, Np. 60 Roller 9 Pitch
39	D58126	1	Shaft, Agitator
40	73368	1	Link, No. 60 Roller Chain Connecting
41	D58230	1	Paddle, STD Vertical Agitator Arm (Inner)
43	D58080	1	Wheel, Rotary Agitator (Ass'y)(Optional)
	D58160	1	Disc (For above)
	D58170	6	Paddle (For Above)
44	D58293	1	Bearing, Paddle Wheel
45	75339	1	Capscrew, 3/4" x 3 1/2"
46	71277	2	Bolt, 3/8" x 1"
47	72591	2	Washer, 3/4" Wide Rim
48	72375	1	Nut, 3/4" Hex Lock
50	72595	1	Bushing, 3/4" NR Machine
51	72256	1	Nut, Jam
52	D28370	1	Bushing, 3/4" Machine (Thick)
54	D58091	1	Shovel, Horiz Agit (Std.)
55	D58095	1	Plate, Mounting

Note: For nuts, washers and lockwashers, see page 63.

GEARBOX ASSEMBLY  
GT D28241

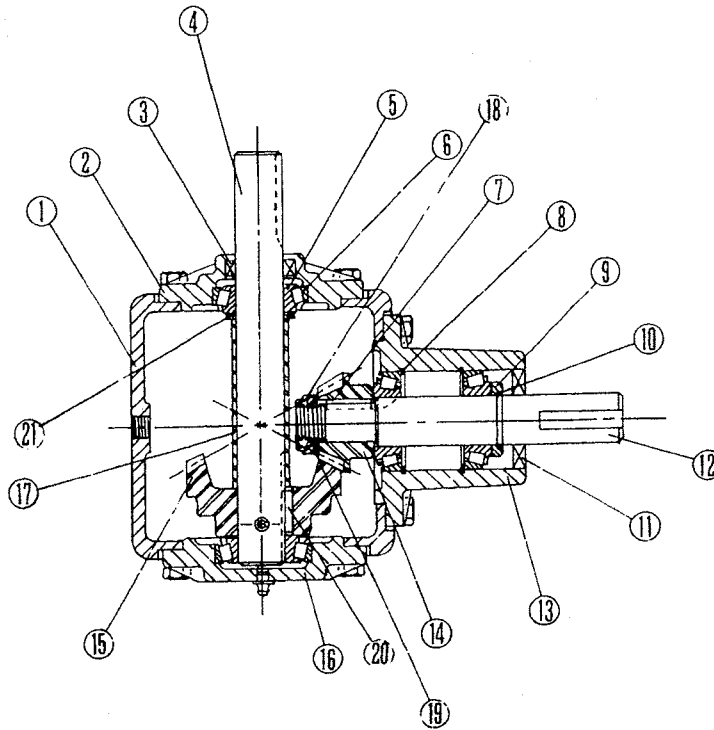

Identification No. D28241 is located on a metal tag under cap bolt.

REF. NO.	PART NO.	NO. REQ'D.	DESCRIPTION
1	77400		Housing
2	42-16144		Cap
	42-16152		Sems Cap Screws
3	42-16146		Seal
4	77401		Shaft
5	42-16147		Bearing Cone
6	42-16148		Bearing Cup
	42-16155		Gasket (.015)
	42-16156		Gasket (.005)
7	77402		Key
8	77403		Retaining Ring
9	77404		Collar
10	77405		Retaining Ring
11	77406		Seal
12	77414		Shaft
13	77408		Cap
14	77079		Gear
15	77080		Gear
16	77412		Cap
17	42-90058		Spacer
18	77410		Locknut
19	77409		Washer
20	77411		Key
21	42-90057		Washer
	42-16151		Roll Pin
	77413		Pipe Plug (Solid)
	72924		Relief Valve
	72921		Reducer





# PLENUM ASSEMBLY

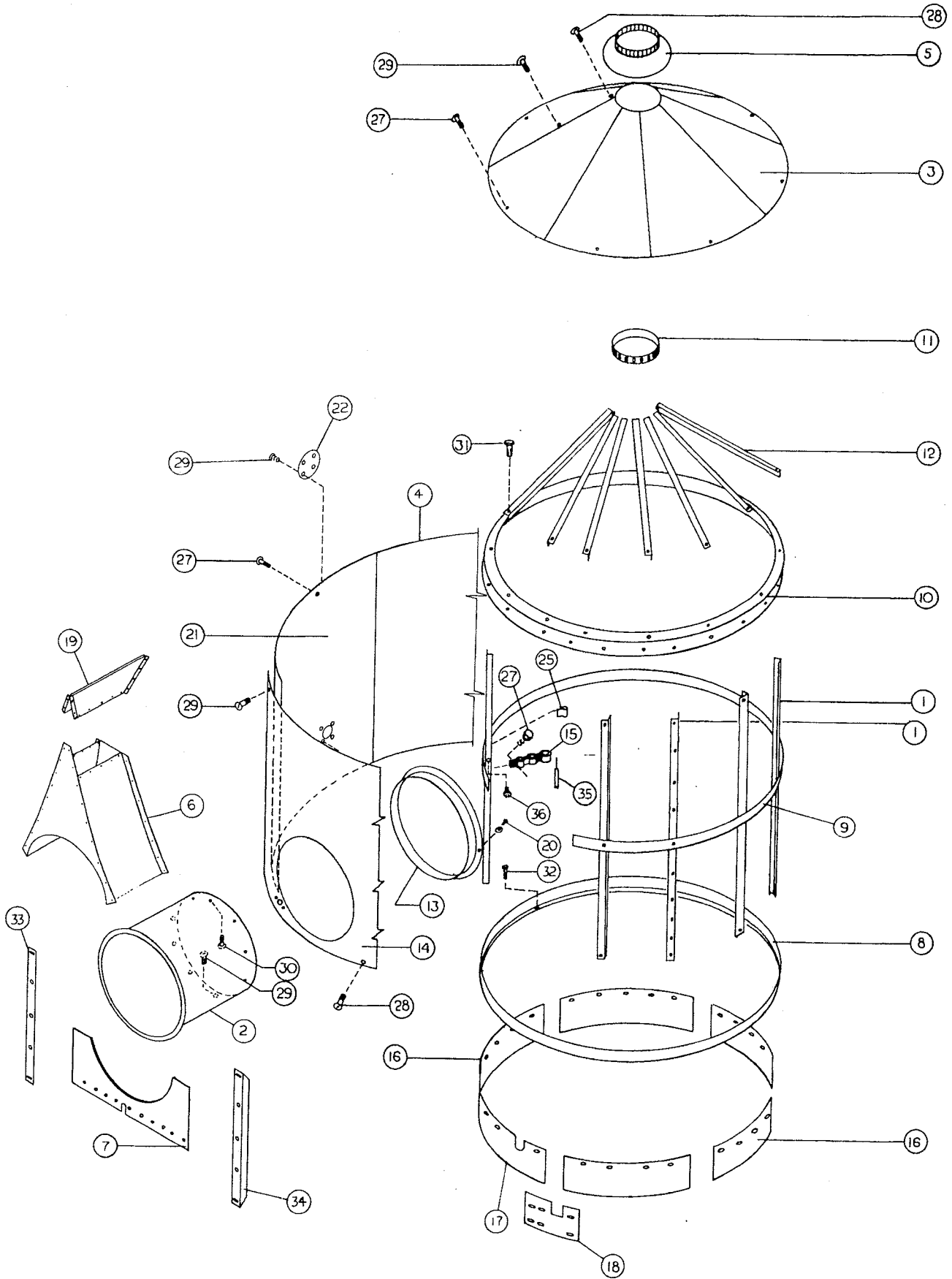

PLENUM ASSEMBLY

REF. NO.	PART NO.	NO.REQ'D.	DESCRIPTION
1	D33010	31	Plenum Frame Angle, Straight
1	D33011	31	Plenum Frame Angle, 645XL
2	D53020	1	Connecting Tube
3	D53342	7	Lid Sheet
4	D53040	4	Side Sheet without Connecting Tube Hole
4	D53041	4	Side Sheet Plenum, 645XL
5	D23051	1	Cone Cap (545XL)
	D63050	1	Cone Cap (645XL)
6	D53061	1	Saddle
7	D53070	1	Front Enclosure
8	D53080	1	Lower Frame Band
9	D53091	1	Center Band, 1/8" Thick - (2) for 645XL
10	D53100	1	Transition Band
11	D53110	1	Top Ring
12	D53120	35	Lid Frame Angles
	D63120	35	Lid Frame Angles, RB600
13	D53130	1	Connecting Tube Trim Ring
14	D53140	1	Sheet with Connecting Tube Hole
14	D53141	1	Plenum Sheet with Connecting Tube Hole 645XL
	D53150	1	Side Sheet (Narrow Strip)
	D53151	1	Plenum Side Sheet-Narrow, 645XL
15	D23161	2	Thermometer Support Bracket
16	D53172	5	Skirt
17	D53182	1	Skirt with Slot
18	D53192	6	Splices, Plenum Skirt
19	D53160	1	Extension, Saddle
19	D53161	1	Extension Saddle 645XL
20	71942	11	No. 14 x 3/4" Self Tapping Screw
21	D53210	1	Side Sheet with Cleaner Hole
21	D53211	1	Side Sheet with Cleaner Hole 645XL
22	D24210	1	Plate, Cover
25	D23210	2	Push on Clip
27	71823	85	1/4" - 20 x 1/2" Slotted Hd Machine Screw
28	71825	108	1/4" - 20 x 3/4" Slotted Hd Machine Screw
29	71822	104	1/4" - 20 x 3/8" Slotted Hd Machine Screw
30	71942	14	#14 x 1/2 Self Tapping Screw
31	71001	35	1/4" x 3/4" Capscrew
32	72155	6	5/16" x 3/4" Self Tapping Hex Hd Screw
33	D54320	1	Stiffener, Front Sheet, Right
34	D54330	1	Stiffener, Front Sheet, Left
35	77271	1	Sensor, Temperature Plenum, Micro
36	77567	1	Hi Limit, Sensor
	D23230	1	Bracket, Sensor
	72958	1	Nut, Brass Sensor
	72522	1	Spacer, Sensor Washer
	72490	35	Spacer, Lid Angle RB600

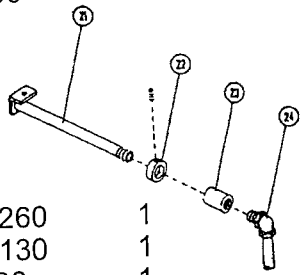

21	D24260	1	Pipe, Agitator Sensor Grain Wall
22	D22130	1	Collar Set
23	72836	1	Coupler, 1/2"
24	73159	1	Elbow, 3/8" Conduit

Note: For nuts, washers and lockwashers, see page 63.

# AUGER ASSEMBLY

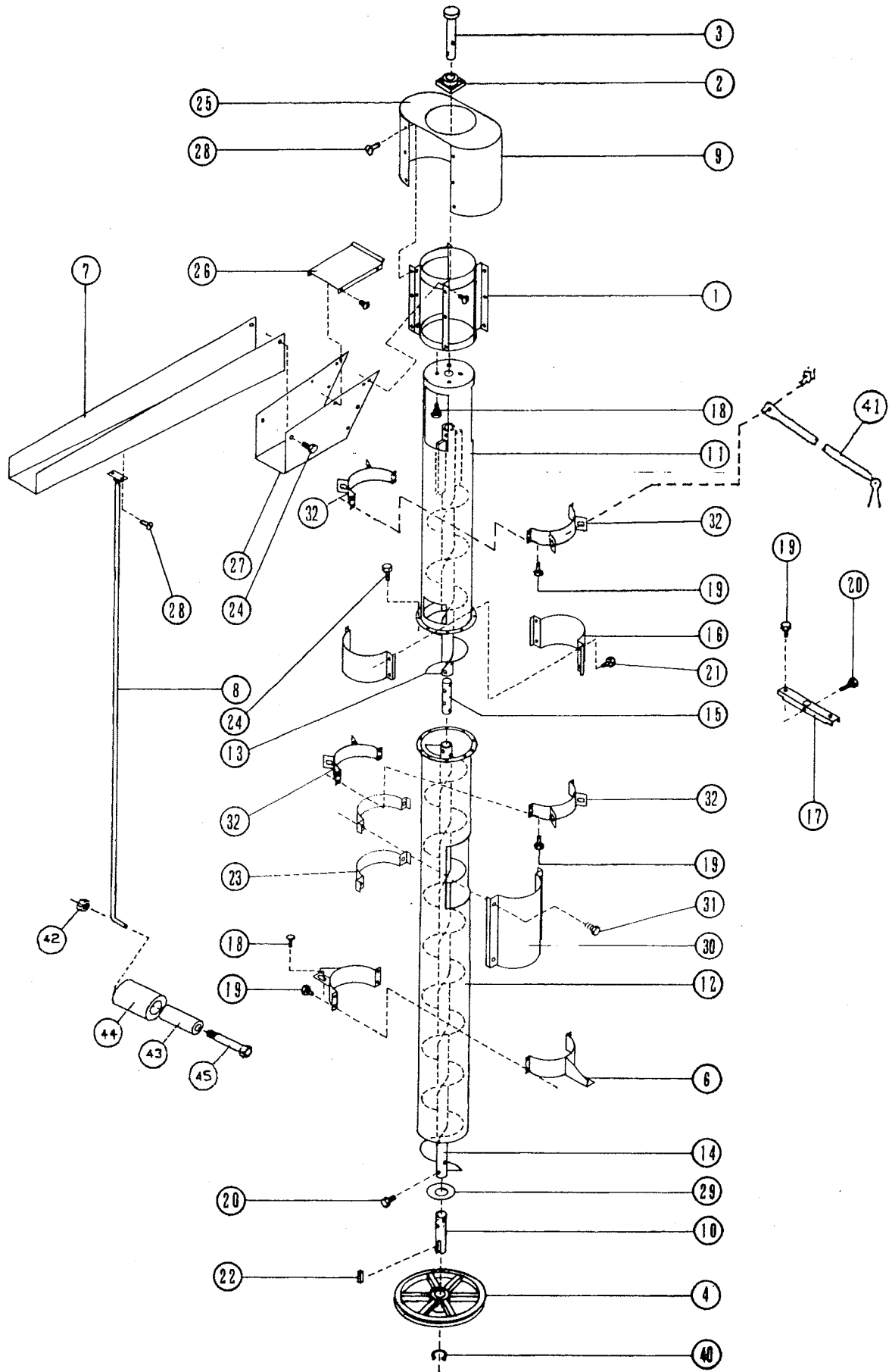

AUGER ASSEMBLY

REF. NO.	PART NO.	NO.REQ'D.	DESCRIPTION
1	D26013	1	Swivel Head
2	D21161H	1	2" Flange Bearing
3	D26020	1	Upper Stub Shaft
4	76090	1	Sheave 1C 18.0 L/SF Hub
	76045	1	Hub, 2" SF QD
6	D26065	2	Clamp, Support (at Spider)
7	D36071	1	Spout
7	D76070	1	Spout 645XL
8	D36081	1	Spout Control Handle
8	D76081	1	Spout Control Handle 645XL
9	D26091	1	Head Baffle, Side
10	D26101	1	Lower Stub Shaft
11	D36111	1	Auger Tube (Top Section)
11	D76112	1	Auger Tube (Top Section) 645XL
12	D56120	1	Auger Tube (Bottom Section)
12	D56121	1	Auger Tube (Bottom Section) 645XL
13	D36131	1	Flighting (Top Section)
13	D76132	1	Flighting (Top Section) 645XL
14	D36141	1	Flighting (Bottom Section)
14	D36142	1	Flighting (Bottom Section) 645XL
15	D26150	1	Stub Connecting Shaft
16	D26162	2	Inspection Hole Cover
17	D26170	1	Split Auger Support
17	D66170	1	Split Auger Support 645XL
18	71329	6	1/2" x 1 1/2" Carriage Bolt
19	71056	8	3/8" x 2" Capscrew
20	73520	8	5/8" x 3 1/2" Capscrew
21	71001	4	1/4" x 3/4" Capscrew
22	73417	1	1/2" x 1/2" x 1 1/2" Key
23	D41030	2	Cleaning Attachment Band
24	71052	12	3/8" x 1" Capscrew
25	D26180	1	Head Baffle, Top
26	D26190	1	Head Baffle, Spout Cover
27	D26200	1	Head Baffle, Spout
28	71825	26	1/4" - 20 x 3/4" Slotted HD Machine Screw
29	72424	1	2" Washer
30	D26220	1	Grain Cleaner Hole Cover
31	71054	4	3/8" x 1 1/2" Capscrew
32	D26057	2	Clamp, Brace (4 on 645XL)
40	69503	1	Snap Ring
41	D74076	4	Brace, Upper Auger 645XL
42	72379	1	Nut, 1/2" Lock
43	D57155	1	Tube, 1 x .5 x 3.75
44	03518	1	Grip, 1" I.D. Rubber
45	71113	1	Capscrew, 1/2" x 4 1/2"
	DA26000	1	Includes Item Number 1, 9, 25, 26, 27 Assembled
	73180	1	Flighting Repair Section

Note: For nuts, washers and lockwashers, see page 63.

OUTSIDE SKIN ASSEMBLY

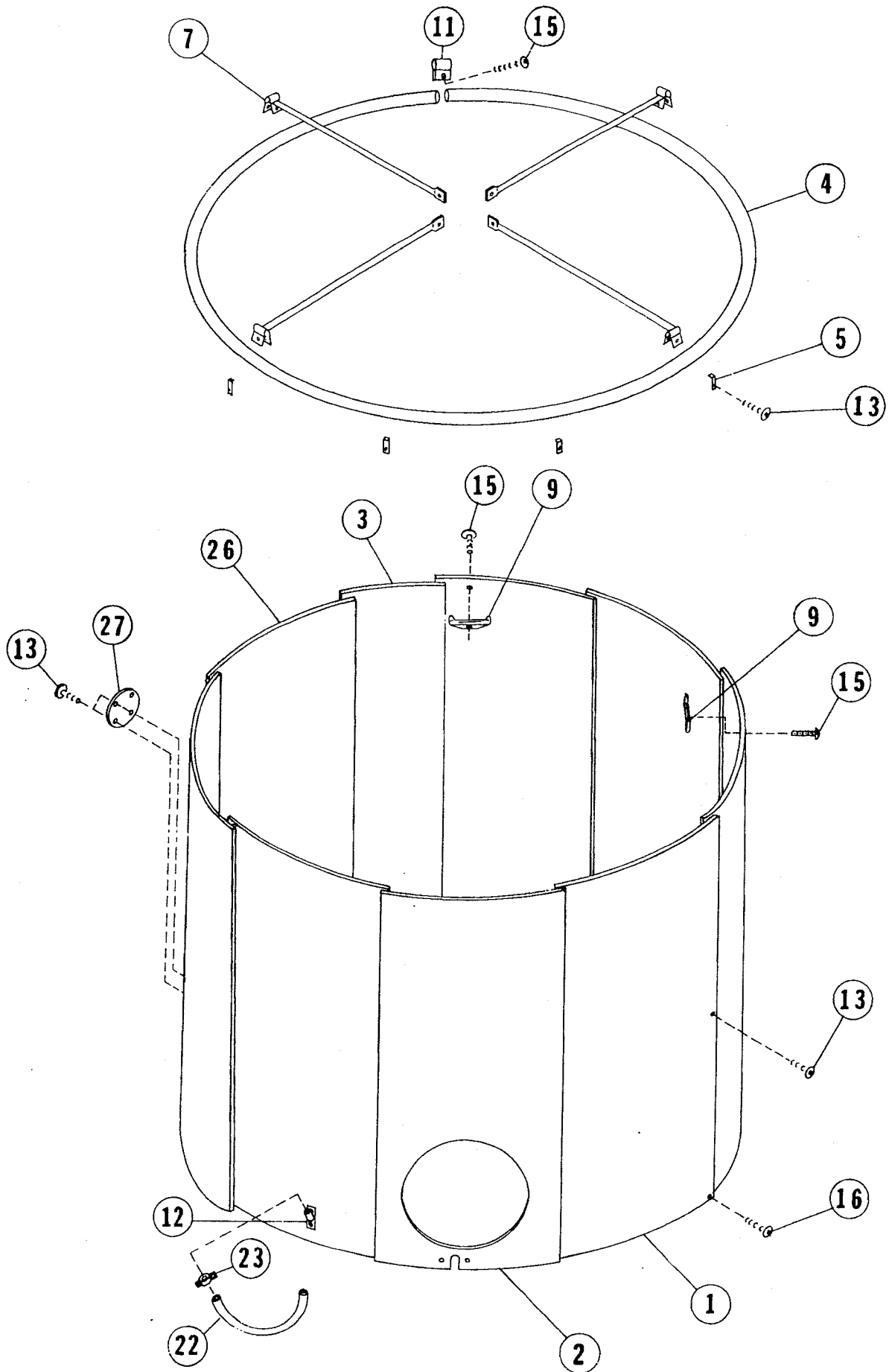

## 545XL OUTSIDE SKIN ASSEMBLY

REF. NO.	PART NO.	NO. REQ'D.	DESCRIPTION
1	D54260	6	Outside Sheet Fine Perforated (Coated)
1	D53380	6	Outside Sheet Fine Perforated
1	D54300	6	Outside Sheet Std. Perforated (Coated)
1	D54010	6	Outside Sheet Std. Perforated
2	D54240	1	Outside Sheet with Hole Fine Perforated (Coated)
2	D53391	1	Outside Sheet with Hole Fine Perforated
2	D54280	1	Outside Sheet with Hole Std. Perforated (Coated)
2	D54021	1	Outside Sheet with Hole Std. Perforated
3	D54270	1	Outside Sheet 34" Wide Fine Perforated (Coated)
3	D53400	1	Outside Sheet 34" Wide Fine Perforated
3	D54310	1	Outside Sheet 34" Wide Std. Perforated (Coated)
3	D54090	1	Outside Sheet 34" Wide Std. Perforated
4	D54040	1	Cap Ring
5	D24050	8	Ring Holder
7	D54072	4	Auger Brace
8	D24080	1	Spout Control Catch
9	D24091	2	Spout Support
11	D24110	1	Rim Connector
12	D24131	1	Grain Temperature Capillary Support Bracket
13	71822	220	1/4" - 20 x 3/8" Slotted Hd. Machine Screw
15	71825	12	1/4" - 20 x 3/4" Slotted Hd. Machine Screw
16	71823	105	1/4" - 20 x 1/2" Slotted Hd. Machine Screw
22	D54191	1	Liquitite Conduite
23	73263	1	3/4" Two Screw Connector
26	D54250	1	Outside Sheet with Hole for Grain Cleaner-Fine Perf. (Coated)
26	D54221	1	Outside Sheet with Hole for Grain Cleaner-Fine Perf.
26	D54290	1	Outside Sheet with Hole for Grain Cleaner-Std. Perf. (Coated)
26	D54201	1	Outside Sheet with Hole for Grain Cleaner-Std. Perf.
27	D24210	1	Cover Plate
	73966	1	(GT Logo)
	A54000	1	Ladder Kit

645XL OUTSIDE SKIN AND EXTENSION ASSEMBLY

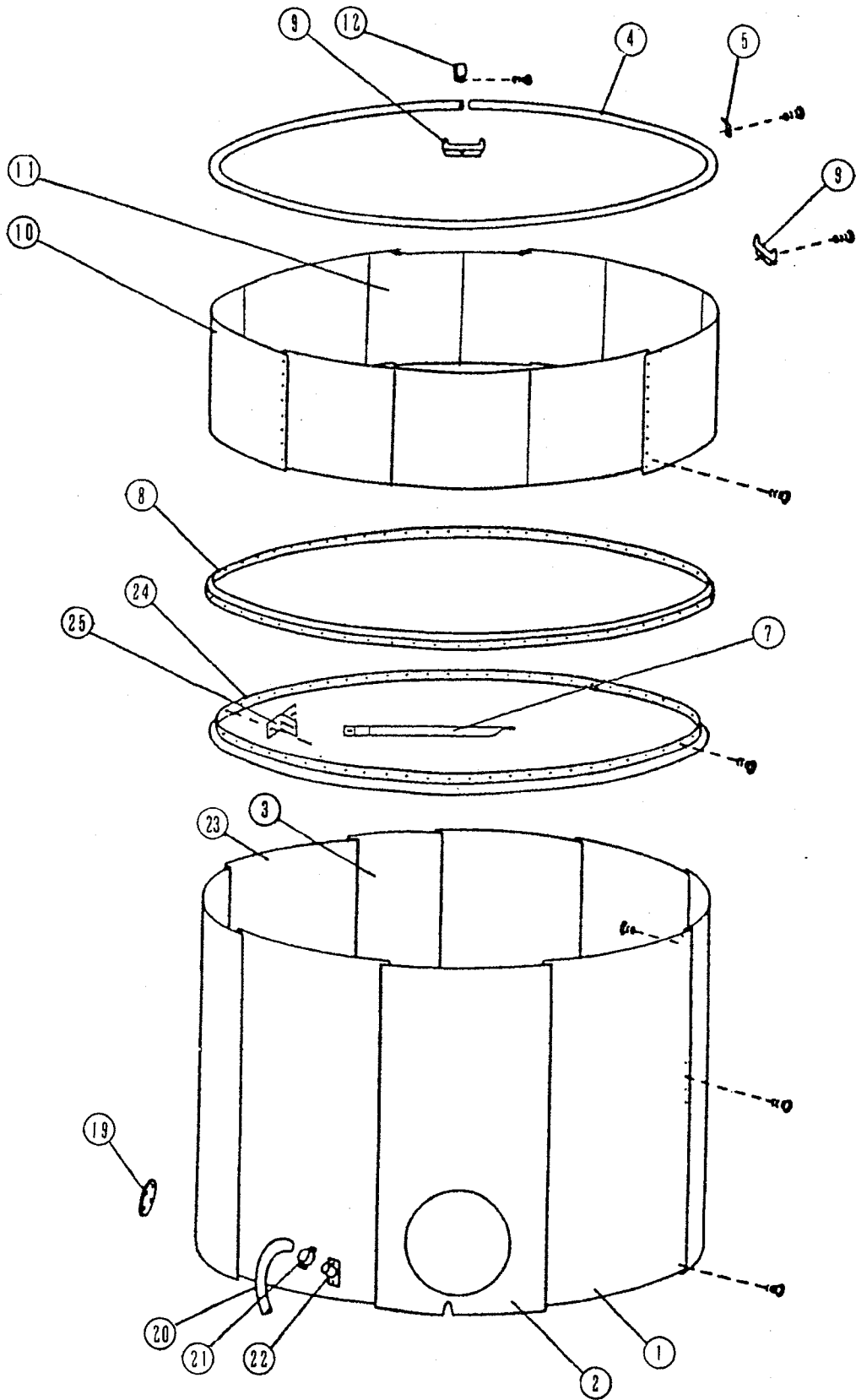



645XL OUTSIDE SKIN AND EXTENSION ASSEMBLY

REF. NO.	PART NO.	NO. REQ'D.	DESCRIPTION
1	D74260	6	Outside Sheet Fine Perf. Coated
1	D74500	6	Outside Sheet Std. Perf. Coated
1	57001339	6	Outside Sheet Fine Perf.
1	57001305	6	Outside Sheet Std. Perf.
2	D74240	1	Outside Sheet w/hole, Fine Perf. Coated
2	D74480	1	Outside Sheet w/hole, Std. Perf. Coated
2	D73390	1	Outside Sheet w/Burner H. Fine Perf.
2	D74020	1	Outside Sheet w/Burner H. Std. Perf.
3	D74270	1	Outside Sheet 34" Wide, Fine Perf. Coated
3	D74510	1	Outside Sheet 34" Wide, Std. Perf. Coated
3	57001340	1	Outside Sheet 34" Wide, Fine Perf.
3	57001320	1	Outside Sheet, 34" Wide Std. Perf.
4	D54040	1	Cap Ring
5	D24050	8	Ring Holder
7	D54076	4	Brace, Middle Auger
8	57001328	1	Band, Dryer Top
9	D24091	2	Spout Support, Extended
10	D74522	8	Sheet, Extension Std. Coated
10	D74232	8	Sheet, Extension Fine Perf. Coated
10	D74462	8	Sheet, Extension Std. Perf.
10	D74132	8	Sheet, Extension Fine Perf.
11	D74560	1	Sheet, Extension Std. Perf. Coated
11	D74570	1	Sheet, 34" Extension Fine Perf. Coated
11	D74540	1	Sheet, 34" Wide Extension Std. Perf.
11	D74550	1	Sheet, 34" Wide Extension Fine Perf.
12	D24110	1	Rim Connector
19	D24210	1	Cover Plate
20	D25262	1	Liquid Tight Conduit
21	73263	1	3/4" Two Screw Connector
22	D24131	1	Grain Temp. Cap. Support Bracket
23	D74250	1	Outside Sheet w/Grain Cleaner Hole Fine Perf. Coated
23	D74490	1	Outside Sheet w/Grain Cleaner Hole, Std. Perf. Coated
23	D74220	1	Outside Sheet w/Grain Cleaner Hole Fine Perf.
23	D74200	1	Outside Sheet w/Grain Cleaner Hole Std. Perf.
24	57001328	1	Band, Top Angle
25	D54065	4	Base, Brace, Large Plenum
	A74000		Ladder Kit

# LOADING HOPPER & DRIVE ASSEMBLY

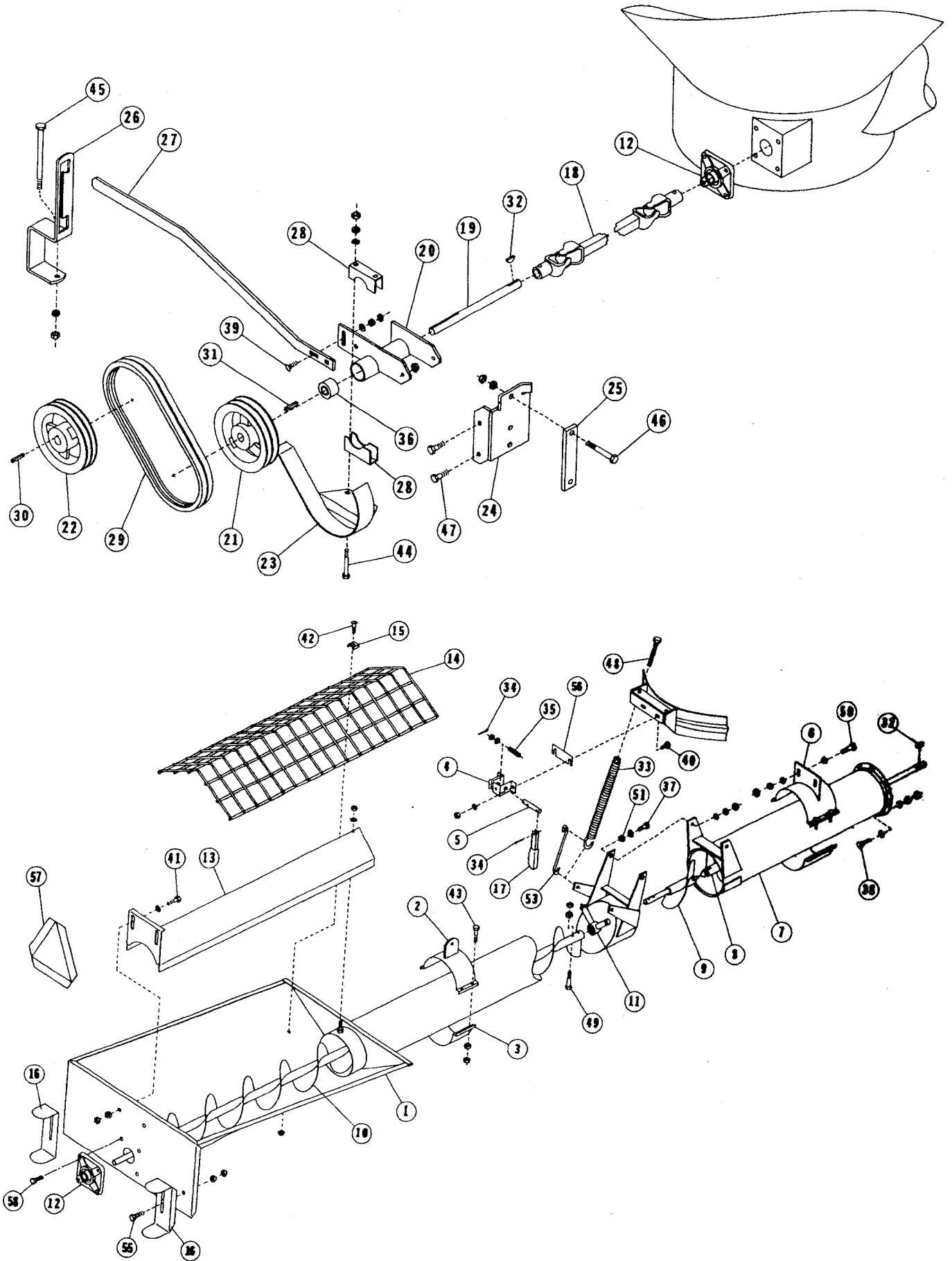

LOADING HOPPER & DRIVE ASSEMBLY

REF. NO.	PART NO.	NO.REQ'D.	DESCRIPTION
1	D29013	1	Hopper, Extended
2	D59540	1	Catch, Hopper
3	41-10143	1	Band, Half
4	D29521	1	Latch, Hopper
5	D29540	1	Pin, Latch
6	D59141	1	Mount, Tube
7	D59031	1	Tube, Front Auger
8	D59053	1	Flight, Front Auger
9	D59391	1	Flight, Short Sec. Rear Auger
10	D29042	1	Flight, Long Sec. Rear Auger
11	42-98080	1	Bearing & Casting
	71127	1	Capscrew, 5/8" x 1"
	D29510	1	Bolt w/Zerk
	42-18183	1	Bronze Bearing
12	42-66022	2	Bearing
13	D59150	1	Regulator, Grain Flow
14	D29470	1	Grill, Hopper
15	D29560	4	Clip, Grill
16	D29161	2	Stand, Hopper
17	D29531	1	Latch Handle
18	D59343	1	Tumbler (See page 32 for parts)
19	D22850	1	Jackshaft
20	D29490	1	Housing, L.H. Jackshaft
21	76089	1	Sheave, 2B6.6 L/SDS Hub
	76084	1	Hub, 1" SDS
22	76089	1	Sheave, 2B6.6 L/SDS Hub
	76007	1	Hub, 1.5" SDS
23	D29372	1	Guard, Belt
24	D29352	1	Bracket, Jackshaft
25	D52720	1	Strap
26	D59382	1	Lock, Clutch
27	D59362	1	Handle, Clutch
	03519	1	Grip, Bar
28	42-16453	2	Clamp, Mount
29	D59322	1	Belt, B58 (Set of 2)
30	73411	1	Key, 3/8" x 3/8" x 1 1/2"
31	42-66057	1	Key, 1/4" x 1/4" x 1 1/2"
32	42-18282	2	Key, No. 808 Woodruff
33	73317	2	Spring, Lift
	D29480	2	Spring, Lift w/plug nut
34	73534	2	Pin, Cotter, 1/8" x 1/4"
35	73316	1	Spring, Pin
36	42-16334	2	Bearing, 1"
37	71079	2	Capscrew, 7/16" x 1 1/2"
38	71027	8	Capscrew, 5/16" x 1"
39	71277	1	Bolt, Carriage 3/8" x 1"
40	71251	8	Bolt, Carriage 5/16" x 3/4"
41	71026	2	Capscrew, 5/16" x 3/4"
42	71825	4	Screw, 5/16" x 3/4" SL HD Machine
43	71054	8	Capscrew, 3/8" x 1 1/2"
44	71038	2	Capscrew, 5/16" x 4 1/2"
45	71066	1	Capscrew, 3/8" x 6"
46	71112	2	Capscrew, 1/2" x 4"
47	71103	2	Capscrew, 1/2" x 1 1/4"
48	71988	2	Capscrew, 1/2" x 6" Full Thd
49	71083	2	Capscrew, 7/16" x 2 1/2"
50	71329	2	Bolt, Carriage 1/2" x 1 1/2"
51	D29020	2	Spacer, 1/2" ID x 1" OD x 5/16"
52	71303	1	Bolt, Carriage, 7/16" x 1 1/4"
53	D59172	2	Rod, Spring Connecting
55	71051	2	Capscrew, 3/8" x 3/4"
56	D29550	As Req'd.	Spacer, Hopper Latch
57	73899	1	Decal, Slow Moving Vehicle
58	71053	8	Capscrew, 3/8" x 1 1/4"

Note: For nuts, washers and lockwashers, see page 63.

# HYDRAULIC UNLOAD HEAD

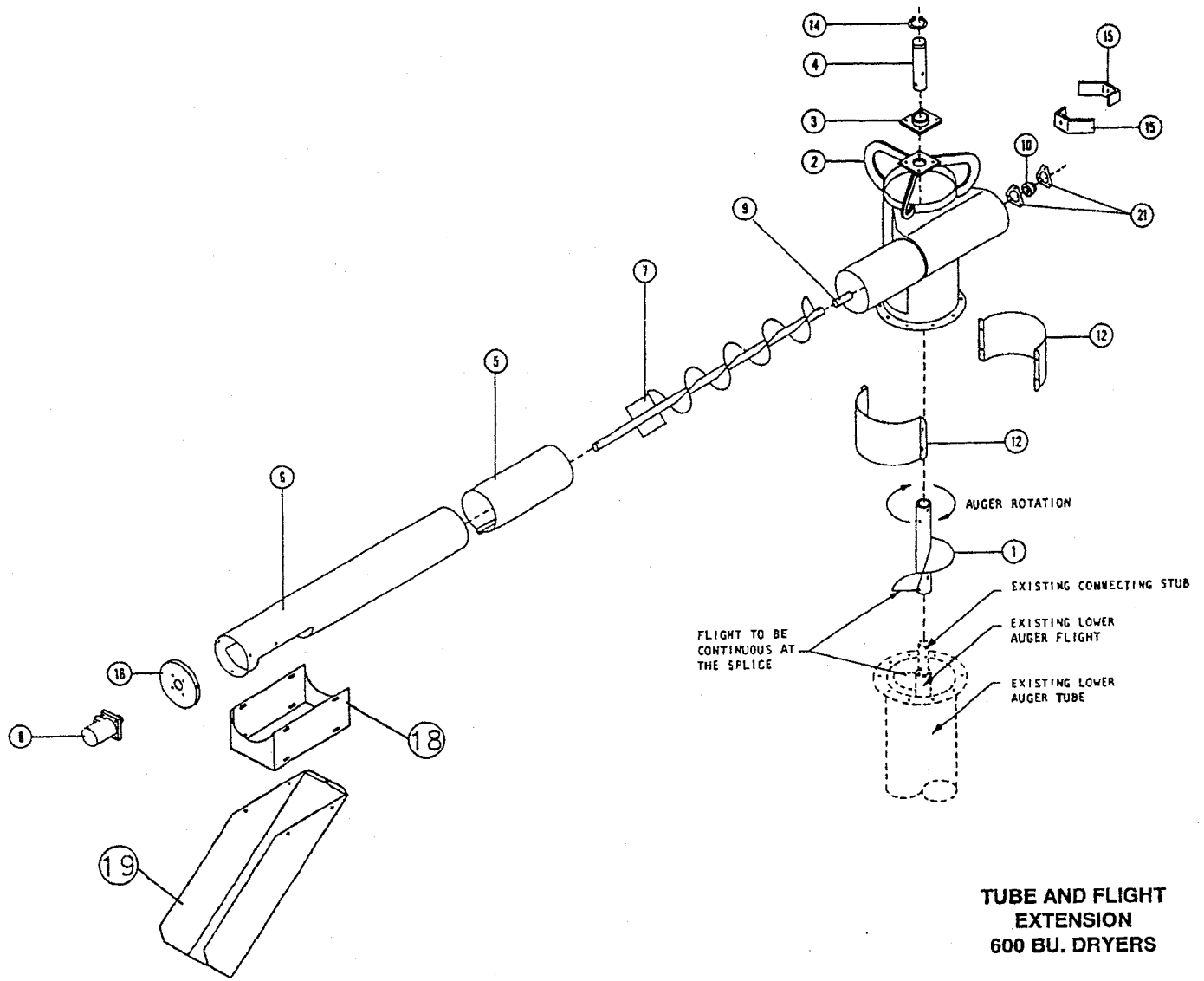

## TUBE AND FLIGHT EXTENSION 600 BU. DRYERS

# ELECTRIC UNLOAD HEAD

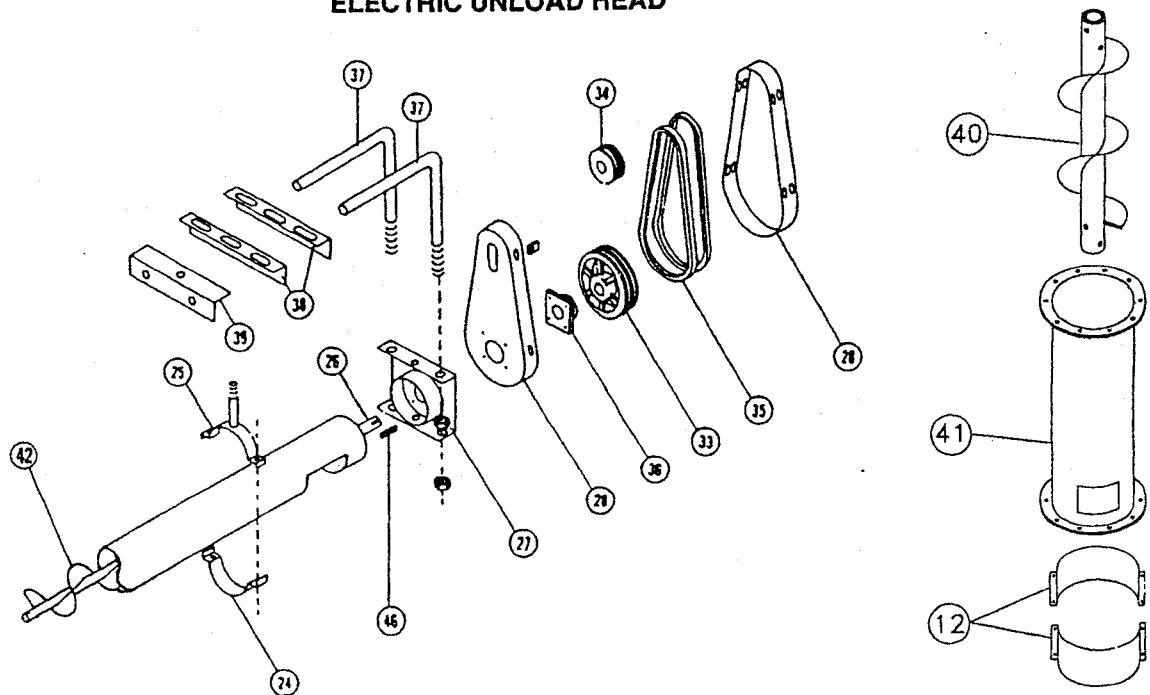

## HYDRAULIC & ELECTRIC UNLOAD HEAD PARTS LIST

REF. NO.	PART NO.	NO. REQ'D.	DESCRIPTION
1	D26311	1	Auger, Horiz. Unload, Vertical
2	D26282	1	Head, Top Auger
3	D21161	1	Bearing, 2" Flanged
4	D26021	1	Stub, Top Auger
5	42-58080	1	Band, 8" x 14½" Connecting
6	D26305	1	Housing, Horiz. Unload Auger
7	D26295	1	Flight, Horiz. Unload Auger
8	D26270	1	Motor, M202 Hydraulic
9	42-56211	1	Stub, Flight Shaft
10	85000	1	Bearing, 1"
12	D26162	2	Band, Inspection Hole
14	69503	1	Snap Ring
15	D26441	2	Spreader, Grain
16	D26255	1	End Cap
18	D26265	1	Adapter, Spout
19	D26326	1	Spout, Top Unl. Head
21	42-54054	1 Pair	Retainer, Bearing
23	71051	7	Capscrew, 3/8" x ¾"
24	41-10042	3	Half Band 8"
25	42-58082	1	Band, Rear Motor Support
26	42-58037	1	Stub, Head
	D26291	1	Flight, Horiz. Elect. Unl.
27	42-58049	1	Plate, Head
28	42-58081	1	Guard, Belt
33	76052	1	Pulley, 2B 9.4 L/Hub
33	76069	1	Hub, 1¼" SK
34	75044	1	Pulley, 2B 3" x 24mm
35	D29321	2	Belt, B40
36	42-58052	1	Bearing
37	42-58046	2	Rod, Motor Mounting
38	42-58048	1	Strap, Motor Mount w/Nuts
38	42-58091	1	Strap, Motor Mount
39	42-58083	1	Angle, Rear Motor Support
46	42-58050	1	Key
	D25995	1	Plate, Elec.

# SIDE MOUNT ELECTRIC POWER UNIT ASSEMBLY

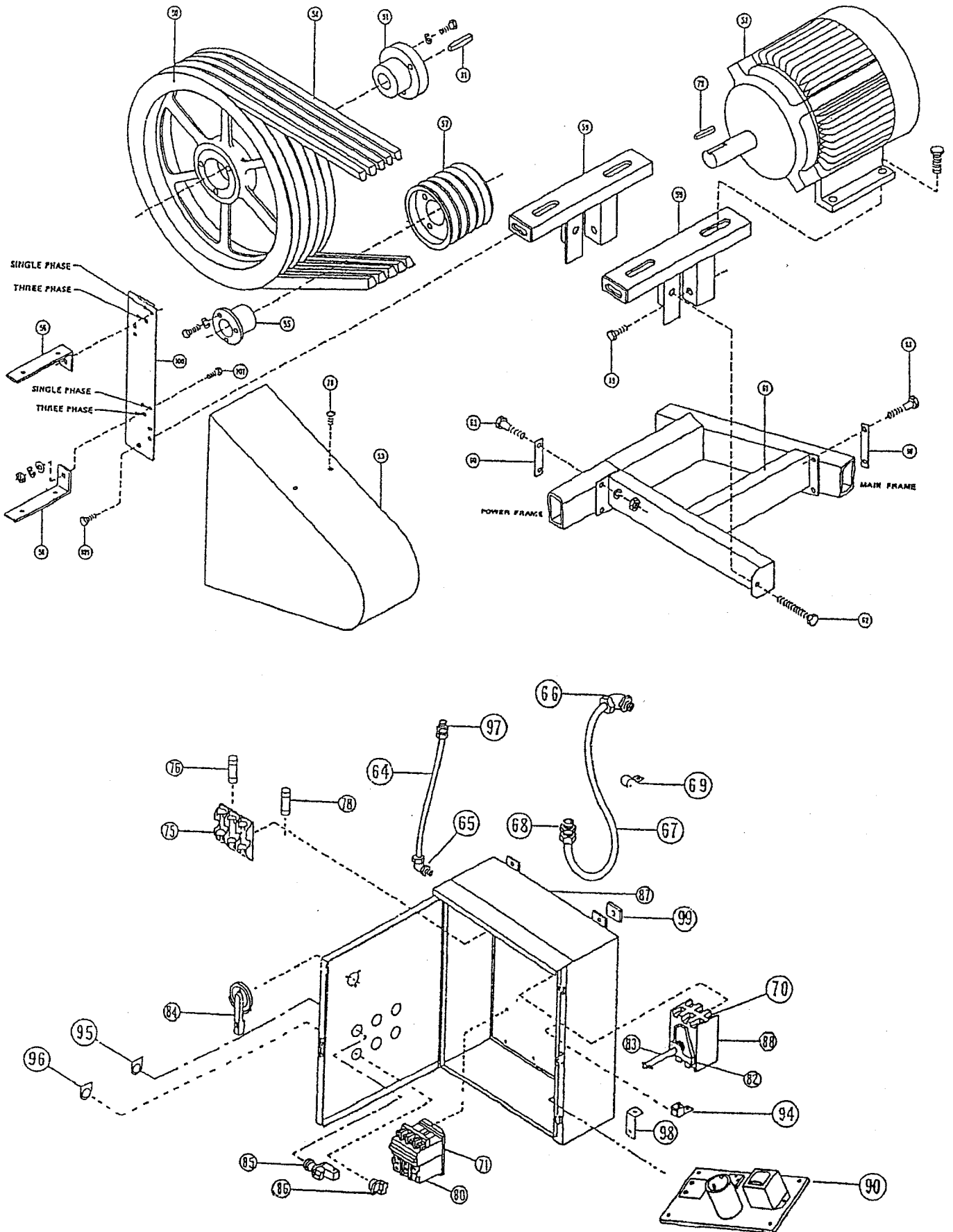

SIDE MOUNT ELECTRIC POWER UNIT ASSEMBLY

REF. NO.	PART NO.	NO. REQ'D.	DESCRIPTION
50	76013	1	Sheave, 5B x 18.4
51	76015	1	Hub, 1½" SF
52	D52391	1	Motor, Electric 25 HP - 500 Bu.
	52-10074	1	Motor, Electric 30 HP - 600 Bu.
53	D59430	1	Guard, Belt
55	76009	1	Hub, 1-7/8" SD
	76066	1	Hub, 48mm SK 50 Hz
56	D32670	2	Bracket, Belt Guard
57	76010	1	Sheave, 5.2 PD 5B
	76033	1	Sheave, 6.2 PD 5B 50 Hz
58	D52990	1	Belt, B88 (Set of 5)
59	D52916	2	Channel, Motor Mount
60	D52720	2	Strap, Mount
61	57001272	1	Frame, Motor Mount
62	71988	1	Capscrew, ½" x 6" Full Thread
63	71112	4	Capscrew, ½" x 4"
64	D54191	1	Conduit, 3/8" Liguatite x 34"
65	73159	2	Elbow, 3/8" Liguatite x 90°
66	73737	1	Elbow, 1" Liguatite x 90°
67	73734	4½'	Conduit, 1" Liguatite
68	73738	1	Connector, 1" Liguatite Straight
69	73742	6	Strap, Conduit
70	73703	3	Terminal, Line
71	77556	1	Starter, Magnetic LCID5011M7 - 500 Bu.
			Starter, Magnetic LCID80M7
75	77558	1	Fuse Block
76	73732	2	Fuse, FRN6
79	73418	1	Key, 5/16" x ½" x 1¼"
80	77553	1	Overload Relay, LR203557 - 500 Bu.
	77624	1	Overload Relay, LR203563 - 600 Bu.
81	73411	1	Key 3/8" Sq. 1½"
84	77327	1	Operating Mechanism
85	77052	1	Button, Push Green Start
86	77051	1	Button, Push Red Stop
87	77027	1	Cabinet
88	77326	1	Breaker, Circuit 100 Amp - 240 Volt
90	DA25010	1	Converter, 110 VAC to 12 VDC
94	77109	1	Lug, Ground
95	73725	1	Plate, Start
96	73726	1	Plate, Stop
97	73157	1	Connector, 3/8" Liguatite Conduit
98	D32050	2	Bracket, Angle Mounting
99	500671	2	Spacer, Neoprene
100	D32660	1	Mount, Belt Guard
101	71052	4	Capscrew, 3/8" x 1"
	D22097	1	Bearing - Optional (Not Shown)
	D52032	1	Mount, Power Shaft - Optional (Not Shown)
	D57116S	1	Extended Power Shaft - Optional (Not Shown)

Note: For nuts, washers and lockwashers, see page 63.

## GRAIN CLEANING ATTACHMENT

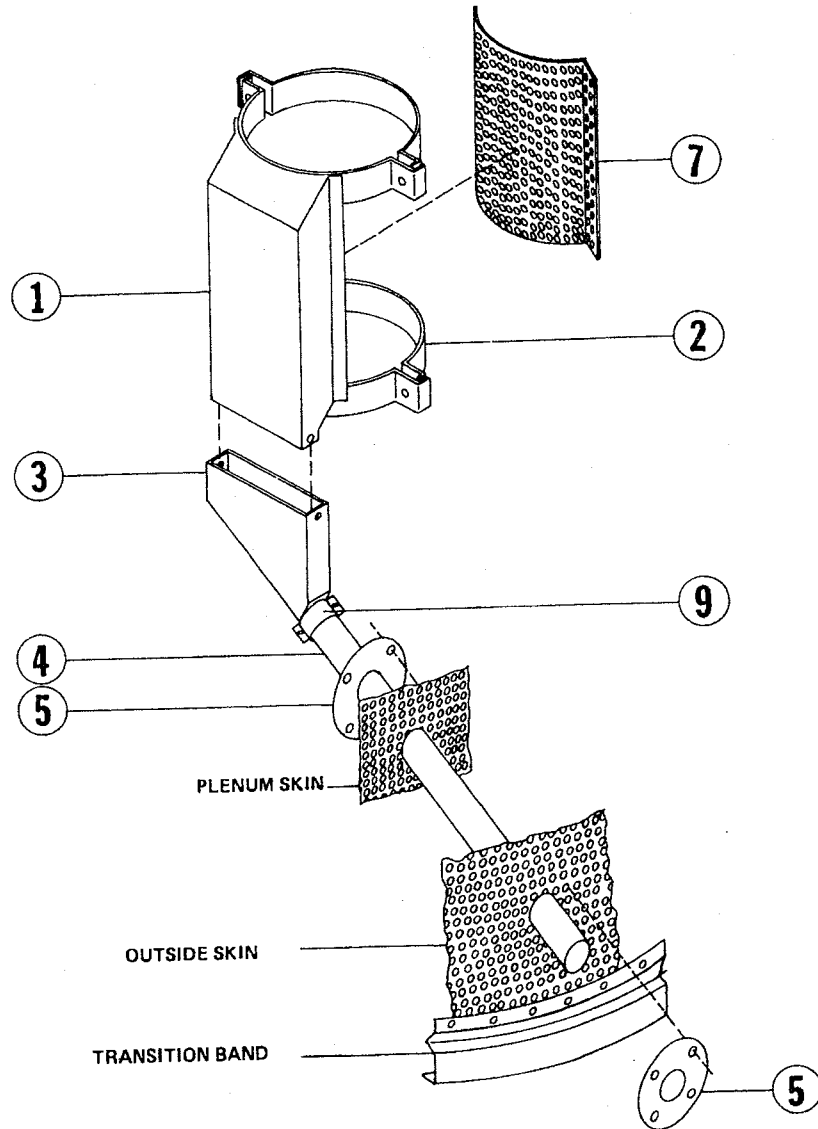

### SIDE MOUNT ELECTRIC POWER UNIT ASSEMBLY



REF. NO.	PART NO.	NO. REQ'D.	DESCRIPTION
	A41011	1	Grain Cleaning Attachment
1	D41020	1	Cleaning Attachment Body
2	D41030	2	Cleaning Attachment Bands
3	D41082	1	Cleaning Attachment Transition
4	D41090	1	Cleaning Attachment Top Tube
5	D41100	1	Flange, Cleaning Attachment Tube
7	A41100	1	Cleaning Attachment Screen (Corn, Sunflower) 7/32" Holes
7	A41110	1	Cleaning Attachment Screen (Wheat, Oats, Barley, Milo)
7	A41120	1	Cleaning Attachment Screen (Soybeans) 5/32" Holes
7	A41130	1	Cover Plate (To replace screen)
7	A41105	1	Cleaning Attachment Screen (Flax) 5/64" Holes
7	A41115	1	Cleaning Attachment Screen (Rape Seed) 1/16" Holes
9	D41081	1	Band, Transition 1/2



NUTS, WASHERS AND LOCKWASHERS

REF. NO.	DESCRIPTION	PART NO.	DESCRIPTION
72208	1/4" Nut	72438	1/4" L-Washer
72209	5/16" Nut	72439	5/16" L-Washer
72210	3/8" Nut	72440	3/8" L-Washer
72211	7/16" Nut	72441	7/16" L-Washer
72212	1/2" Nut	72442	1/2" L-Washer
72213	5/8" Nut	72443	5/8" L-Washer
72380	1/4" L-Nut	72408	1/4" Washer
72379	1/2" L-Nut	72409	5/16" Washer
72375	3/4" L-Nut	72410	3/8" Washer
72382	1/4" Whiz Lock-Nut	72411	7/16" Washer
72334	1/4" Tinnerman Nut	72412	1/2" Washer
72376	5/8" Lock Nut	72413	5/8" Washer

TORQUE ALL BOLTS PER TORQUE SPECIFICATION CHART

COARSE THREAD FASTENER	GRADE DESIGNATION	SCREW, STUD, OR BOLT SHANK SIZE OR DIAMETER							
		1/4"	5/16"	3/8"	7/16"	1/2"	9/16"	5/8"	3/4"
 CAP SCREW	S.A.E. 2 STEEL	5	11	20	30	50	70	100	170
 CAP SCREW	S.A.E. 2 STEEL	8	17	30	50	75	110	150	270
 CAP SCREW	S.A.E. 2 STEEL	12	24	45	70	105	155	210	375

Torques are in ft - lbs.

Torques shown are for National Coarse Thread Plain or Zinc plated fasteners carrying residual oil of Manufacture.

GRAIN	USED FOR	PLENUM TEMP.	GRAIN TEMP.	DRYING TIME	COOLING TIME



**P.O. Box 525**

**Clay Center, KS 67432 U.S.A.**

**Phone (785) 632-2151**

**Toll Free (800) 423-9428**

**Fax (785) 632-3308**

