

Alan's Book 1996
ENCLAVE ONLY

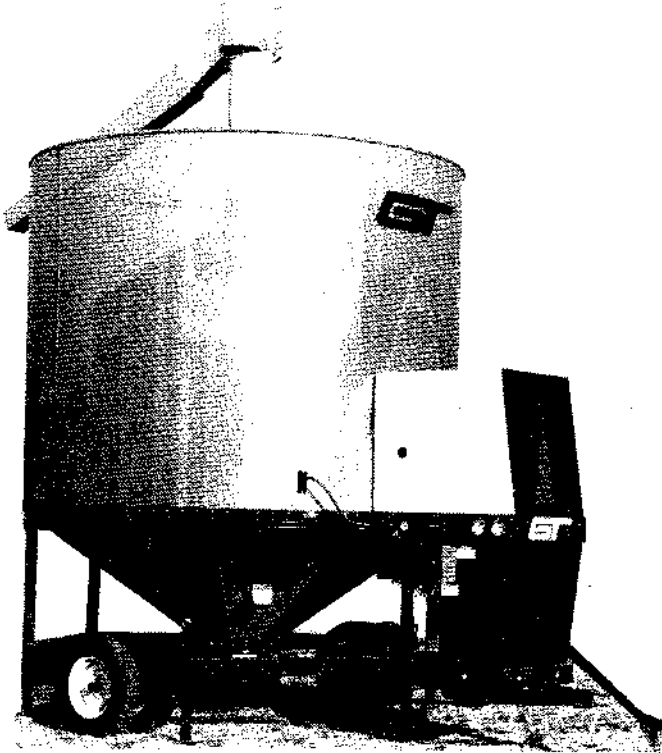

500 SERIES

GRAIN DRYER

OPERATOR'S MANUAL

& PARTS BOOK

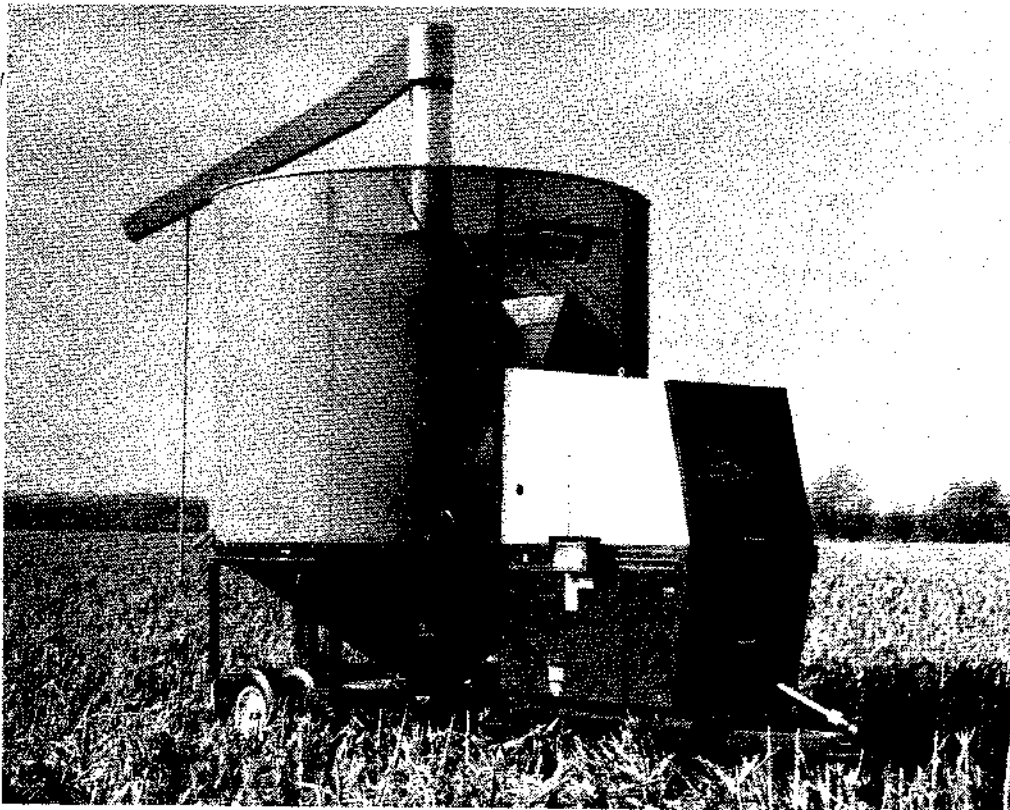

Form S-3093
Printed in U.S.A.

GT Mfg., Inc.

P.O. Box 525 • Clay Center, KS 67432, U.S.A.
(913) 632-2151 • (800) 423-9428 • FAX (913) 632-3308



MANUFACTURERS OF FARM AND INDUSTRIAL EQUIPMENT

500 SERIES
OPERATORS MANUAL & PARTS CATALOG

Your GT Grain Dryer is one of the finest grain dryers ever built; designed to give you excellent service for many years. The information and suggestions found in this owners manual will help you achieve this.

Your GT Grain Dryer dealer is well trained and equipped to give you complete service when and if the need should arise.

We would also like to take this opportunity to thank you for choosing GT and assure you of our continuing interest in your complete satisfaction.

TABLE OF CONTENTS

Battery Connections 12
Bolt Torque Chart 90
Burner Starting Instructions 19
Controls Identification 16-17
Electrical Schematics 29-31
Fuel Flow Chart 26
General Information 8
 Theory of Drying 8
 Rate of Drying 8
 When Grain Is Mature 8
 Storage Moisture Levels 8
 Moisture Testing 9
 Cooling of Grain 9
Installation and Set-Up 10
Lubrication 14
Maintenance:
 General Operating 33
 Microprocessor and Sensors 33
Microprocessor Installation 13
Operating Instructions 16-17
Parts List:
 Agitator Assembly 70
 Auger Assembly 76
 Burner Assembly 54
 Frame Assembly 68
 Gearbox Assembly 73
 Grain Capillary Assembly 79
 Grain Cleaner Assembly 87
 Hydraulic or Electric Unloader 88
 Loading Hopper 82

TABLE OF CONTENTS (continued)

Microprocessor:	
Agitator Sensor Assembly	72
Box Assembly	67
Grain Capillary Assembly	79
PTO Sensor Assembly	50
Vertical Auger Sensor Assembly	51
Nuts, Washers, and Lockwashers	90
Outside Skin Assembly	78
Pelmet Assembly	80
Plenum Assembly	74
Power Unit	41
Propane Controls Assembly	58
Solenoid Valve Assembly	60
Tumbler Assembly	52
Safety Information	3
Sensor Locations	27
Sequence of Operation	32
Storage:	
Preparing Dryer for	34
Removing Dryer from	34
Table of Contents	1-2
Temperature Chart:	
Grain	23
Plenum	23
Transporting the Dryer	35
Trouble Shooting:	
General	36
Microprocessor Control System	38
Wiring Diagram	28-30

SAFETY



DO NOT OPERATE OR ALLOW ANYONE TO OPERATE THIS EQUIPMENT WHO HAS NOT BEEN PROPERLY TRAINED IN ITS SAFE OPERATION.

Throughout your operator's manual and at various locations on your machine you will see the Safety-Alert symbol shown below. This emblem has been adopted by the agricultural equipment industry to provide a universal symbol which means **ATTENTION! BECOME ALERT! YOUR SAFETY IS INVOLVED!**

This symbol is our way of telling you to pay special attention to the instructions or warnings which follow because your safety is involved.



SAFETY-ALERT SYMBOL FOR AGRICULTURAL EQUIPMENT

The following labels found on your machine provide important safety messages and instruction for safe operation.



As these labels become worn, damaged, or illegible replace them immediately. These labels are available at your authorized dealer.

BE A SAFE OPERATOR

BY THINKING — BEFORE ACTING

AND

BY READING YOUR OPERATORS MANUAL

AVOID ACCIDENTS

Most accidents, whether they occur in industry, on the farm, at home, or on the highway, are caused by the failure of some individual to follow simple and fundamental safety rules or precautions. For this reason most accidents can be prevented by recognizing the real cause and doing something about it before the accident occurs.

Regardless of the care used in the design and construction of any type of equipment, there are many conditions that cannot be completely safeguarded against without interfering with reasonable accessibility and efficient operation.

A CAREFUL OPERATOR IS THE BEST INSURANCE AGAINST AN ACCIDENT.

THE COMPLETE OBSERVANCE OF ONE SIMPLE RULE WOULD PREVENT MANY THOUSAND SERIOUS INJURIES EACH YEAR. THAT RULE IS:

STOP MACHINE TO ADJUST, LUBRICATE, SERVICE, CLEAN OR MOVE.



CAUTION

1. Read and understand the Operator's Manual before operating the unit.
2. Keep children, visitors and all untrained personnel away from machine while in operation.
3. Keep all shields and safety devices in place.
4. Stop machine to adjust, lubricate, service, clean or move.
5. Keep hands, feet and clothing away from moving parts.
6. Disconnect electrical power before servicing.
7. Keep unit level when operating.
8. Maintain proper tire pressure when transporting machine. (Refer to Manufacturers Recommendations.)



DANGER

For maximum safety and smoothest operation keep p.t.o. shaft in closed position while under load. Keep u-joint angles equal. Do not remove safety shields. Do not exceed 540 r.p.m.

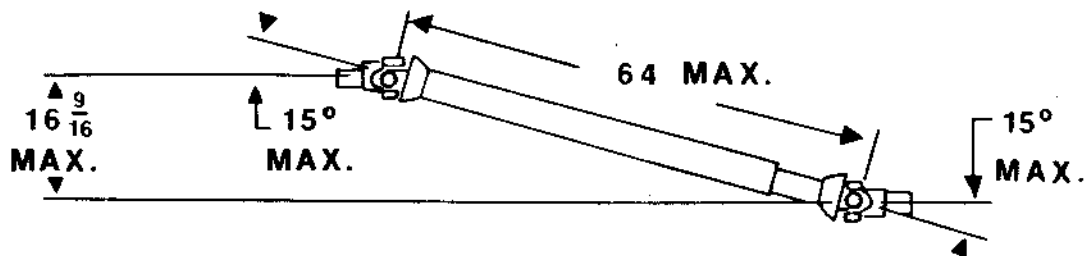

FAILURE TO HEED WILL CAUSE PTO SHAFT FAILURE OR SEPARATION & RESULT IN SERIOUS INJURY OR DEATH.



DANGER



ROTATING DRIVELINE
CONTACT CAN CAUSE DEATH
KEEP AWAY!

DO NOT OPERATE WITHOUT —

- ALL DRIVELINE, TRACTOR AND EQUIPMENT SHIELDS IN PLACE
- DRIVELINES SECURELY ATTACHED AT BOTH ENDS
- DRIVELINE SHIELDS THAT TURN FREELY ON DRIVELINE

L1

279561

DANGER

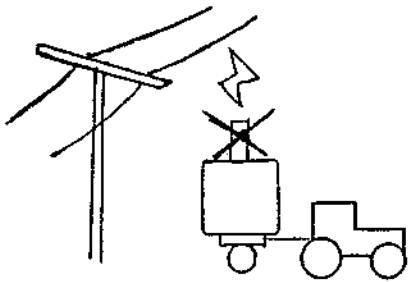

ELECTROCUTION HAZARD

To prevent serious injury or death from electrocution:

- Remove unloading head when transporting.
- Stay away from overhead power lines when transporting.
- This machine is not grounded.
- Electrocution can occur without direct contact.



DANGER

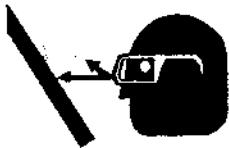

CONNECT TO LIQUID PROPANE ONLY.

Wear Rubber Gloves and Eye Protection.

Avoid Contact with Propane.



Check for Leaks with Soap and Water. NEVER USE FLAME.

CAUTION

**ENGAGE FAN CLUTCH
VERY SLOWLY WHEN
PTO IS OPERATING**



MAX. PTO SPEED 540 R.P.M.

TORQUE WHEEL BOLTS TO 70 LB.-FT.
(94.85 N-M). CHECK TORQUE
BEFORE TOWING AND PERIODICALLY
UNTIL TORQUE IS HELD.

74535

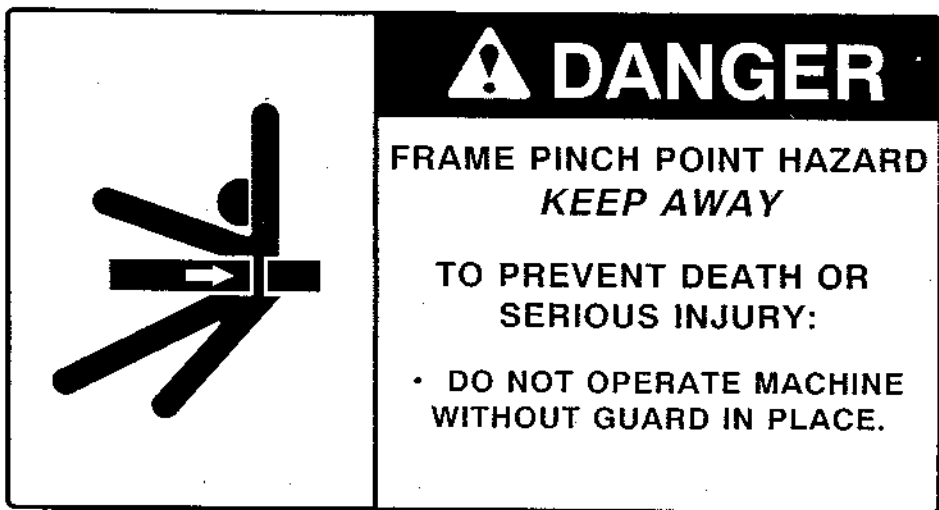



1. Keep all guards and shield in place.



2. Inspect your drive before adding power and know how to shut down in an emergency.



3. Stop all moving parts before allowing anyone to approach the equipment for cleaning, unplugging, adjusting, performing maintenance or any other duty.



4. Replace all safety shields/guards before restarting.



5. Replace all safety shields/guards as they become worn, damaged, unusable, missing or lost.

GENERAL INFORMATION

Mechanical drying of grain is a relatively new process; therefore, emphasis must be placed on proper operation of grain drying equipment. Your GT Dryer was designed and engineered to retain grain quality, and to dry grain as rapidly as possible at the lowest cost consistent with retention of quality grain. Study and follow this manual so you too may enjoy the additional profits derived from drying.

THEORY OF DRYING

The theory of drying has two basic stages: (1) diffusing of internal moisture to the surface of the kernel, and (2) removal of external moisture by air flowing around the kernel. Vapor pressure is increased inside the kernel which causes moisture to diffuse through the micropores of the seed coat. The grain temperature largely establishes this rate of diffusion and hence must be controlled to not exceed a maximum rate which would result in a ruptured kernel.

Removal of the exterior moisture for a given air flow is dependent upon the air temperature. These two stages must be balanced to produce quality dried grain.

This balance is accomplished quite simply in the GT Grain Dryer with its uniform circulation, regulated heat, and controlled air flow.

RATE OF DRYING

In addition to the kind and variety of grain, the drying rate is controlled by atmospheric conditions. Hard and fast rules cannot be set forth because of these variables. It will be necessary to dry several batches to determine the exact dryer settings in a specific area. A chart for recording necessary information for later use is included in the back of this manual.

WHEN GRAIN IS MATURE

Most grain is mature at 30% to 35% moisture. While some grain may be harvested easily at 30%, others do not harvest well above 20%. Therefore, grain should be harvested as soon as possible after maturity, as long as grain damage is at a minimum and gleaning is thorough.

STORAGE MOISTURE LEVELS

To properly store grain, the grain moisture content must be compatible with the length of time the grain will be in storage, and with the grain's intended use. This moisture content will vary due to locale.

GRAIN	1 YEAR STORAGE (% Moisture)
Corn	13%
Wheat	13-14%
Barley	13%
Rice	12%
Oats	13%
Rape Seed	10.5%
Grain Sorghum	12%
Flax	9%
Soybeans	11%
Edible Beans	14-16%
Sunflower Seed (Oil Type)	10%
Sunflower Seed (Bird Seed Type)	12%

Corn may be stored at 15% moisture if moved before warm spring weather. For long time storage — up to 5 years, or for grain stored as seed stock, moisture level should be 2% lower than shown above.

MOISTURE TESTING

Since grain must go into storage at not more than specified moisture content, it is necessary to use a reliable tester to determine moisture content. When marketing grain from the dryer, it should be only dry enough to eliminate moisture discounts. The moisture tester may also be profitably used to determine when to harvest.

COOLING OF GRAIN

It is very important to cool grain. Grain being put in storage should be cooled after drying to within 20 degrees F of atmospheric temperature or, 10 degrees F of grain already in the storage bin. Moisture migration from the air to grain will occur if the grain is not cooled to these limits.

INSTALLATION AND SET-UP

1. INSTALLATION OF EQUIPMENT

The equipment shall be installed in accordance with the installation code for gas burning appliances and equipment, CAN 1-B149 or applicable rate or Provincial Regulations for the class. Instructions should be carefully followed in all cases. Authorities having jurisdiction should be consulted before installations are made.

2. PLACING MACHINE FOR OPERATION

Select a sit as level as possible, 50 ft. (15 meters) from any inhabited building. Set machine, if possible, with fan into prevailing winds. Lower the supporting legs and insert pins. If machine is being set on a level concrete slab, no additional blocking will be necessary. However if being set on dirt, at least a 2" x 8" x 12" board or equivalent should be placed under each leg for additional flotation. Add any additional blocking material necessary to bring machine level. Use a level on the main frame to determine this.

3. INSTALLING TOP SECTION OF AUGER AND ADJUST FOR UNLOADING

When installing the top section of auger, it may be necessary to jack the lower flight up to allow the bolt holes in the connecting shaft to align. The weight of the complete auger should be supported by the top auger bearing when in proper adjustment.

If the dryer is equipped with the standard swivel head, removing bolts through mounting flanges which hold the upper and lower auger tubes together will allow the upper tube to be rotated to provide unloading at several points. It should be also noted that on the standard swivel head when the unloading spout is set for unloading one direction, it will also unload in the opposite direction. One-fourth turn, of unloading spout, relocates the auger head to recirculating position. When unloading or recirculating, the unloading spout must rest in holders provided at top of bin. These holders may be replaced by bin wall and rebolting holders. Should use of both unloading positions be desired, an additional holder may be obtained through your dealers parts department. Be sure that the openings in the upper auger tube and the auger head are properly aligned to insure good circulation.

If the dryer is equipped with the hydraulic drive horizontal top unloading head, the discharge should be set directly off the right or left hand sides of the dryer. It is recommended that the hydraulic lines to the drive motor be connected to a source with a capacity of 7 gallons per minute at 1000 psi.

After connecting hydraulic source to lines at dryer, make certain that the unloading flight has the proper rotation to remove grain from the head. When looking into the discharge end of the auger it should be rotating counter clockwise.

When using the horizontal unloading head, it is not advisable to leave grain set in the dryer for any length of time (such as over night) without the vertical auger operating. If grain must be left in the dryer, it should be lowered to a level below the top of the unload auger head to prevent grain from running back down the vertical auger.

4. LOCATING PROPANE GAS SUPPLY TANK

Location of the Propane Gas Supply Tank must be in accordance with local, state or provincial regulation. It should also be approved by the insurance company. A minimum distance of twenty-five (25) ft. (7.5 meters) is recommended for safety and will allow room for maneuvering grain hauling equipment.

GT Propane Gas fired dryers are equipped with Vaporizers and must be connected to the supply tank for LIQUID withdrawal. It is recommended that rubber hose specifically made for Propane gas be used as a supply line connecting tank to dryer. Specifications for the line are: (1) minimum working pressure 350 psi, (2) minimum bursting strength 1,750 psi, and (3) 3/8" minimum inside diameter. Tank pressure is used at the dryer; therefore, it is not necessary to install a pressure regulator at the tank.

 **DANGER**

All lines and fittings should be checked periodically for leaks before and during operation. Check for leaks with liquid detergent suds or comparable substance, but NEVER with flame. Failure to do so may result in serious injury or death.

 **CAUTION**

Do not use storage tanks that have been used to store Anhydrous Ammonia. This causes corrosion to the gas line controls.

Always protect gas supply line against vehicle or animal damage.

5. **ELECTRICAL CONNECTIONS**

Power take off machines have as standard equipment a 12 VDC negative ground control circuit. The lead in wires must be properly connected to the tractor battery. Red clip to hot (+) side of battery and black clip to ground (—) side of battery. See proper battery connections on page 12.

IMPORTANT: Battery connections other than that described above will be harmful to the ignition system.

BATTERY CONNECTIONS

12 VOLT SYSTEM (ONE 12 VOLT BATTERY)

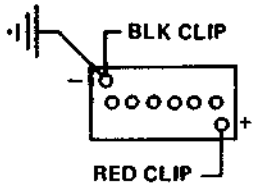

CORRECT

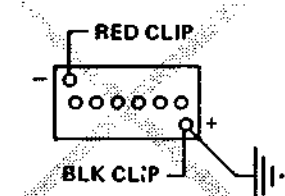

INCORRECT

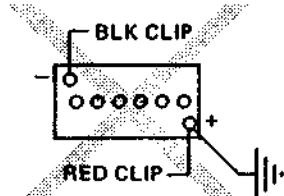

INCORRECT

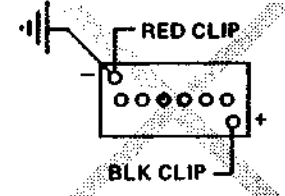

INCORRECT

12 VOLT SYSTEM (TWO 6 VOLT BATTERIES)

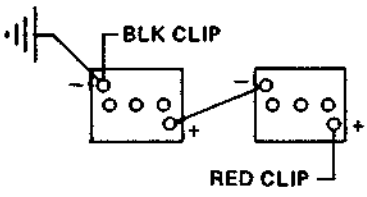

CORRECT

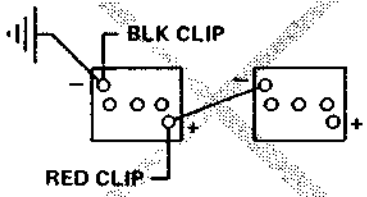

INCORRECT

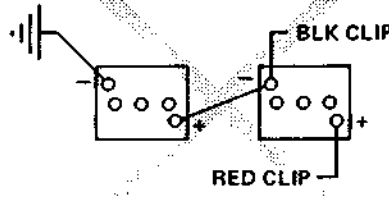

INCORRECT

12 VOLT SYSTEM (TWO 12 VOLT BATTERIES)

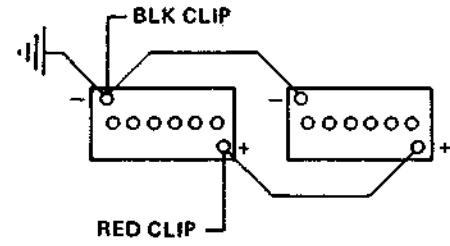

CORRECT

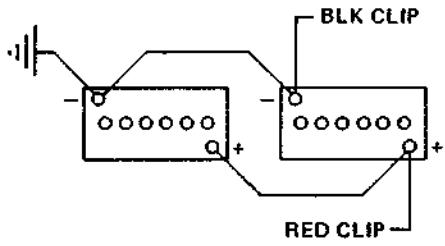

CORRECT

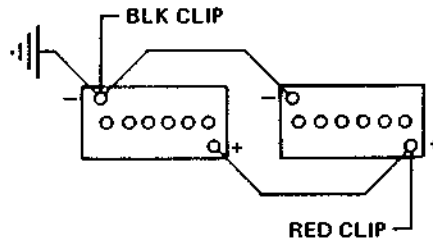

CORRECT

24 VOLT SYSTEM (TWO 12 VOLT BATTERIES)

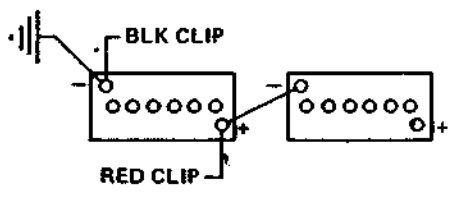

CORRECT

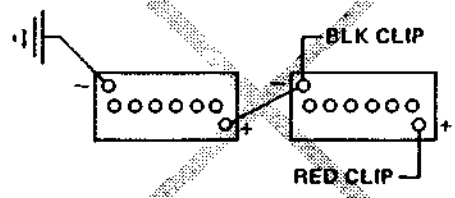

INCORRECT

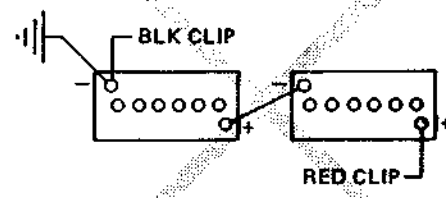

INCORRECT



7. MICROPROCESSOR INSTALLATION

1. Connect cable (6) to rear of the microprocessor box (1). A polarized screw connector locks the cable into place.
2. Mount the microprocessor box (1) to the right front power frame unit by threading the plastic adjusting knobs (3) through mounting brackets (2) and (13) and into the microprocessor box.
3. Adjust the microprocessor box to a convenient angle to reduce glare and improve readability. Tighten adjusting knobs.

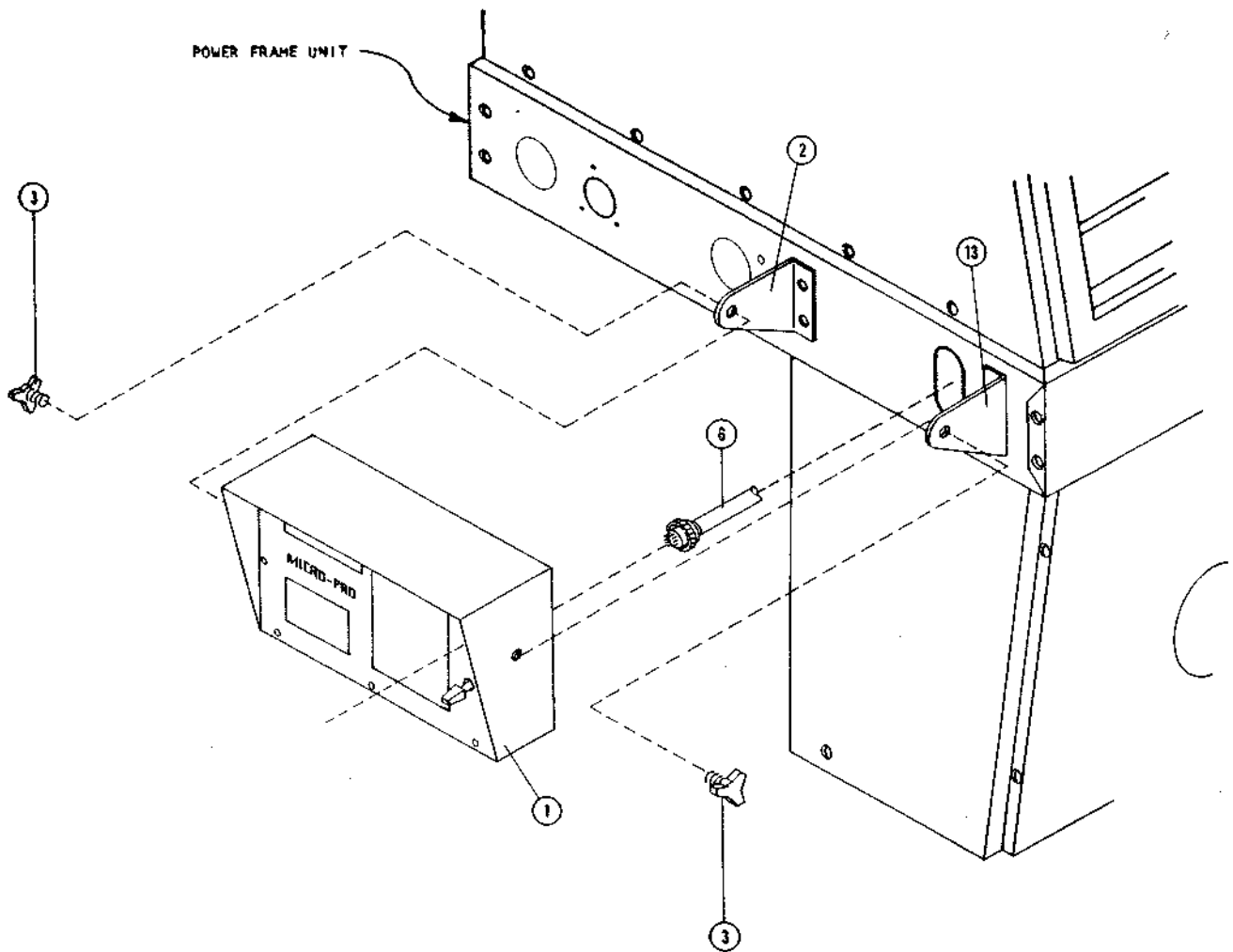

8. LUBRICATION

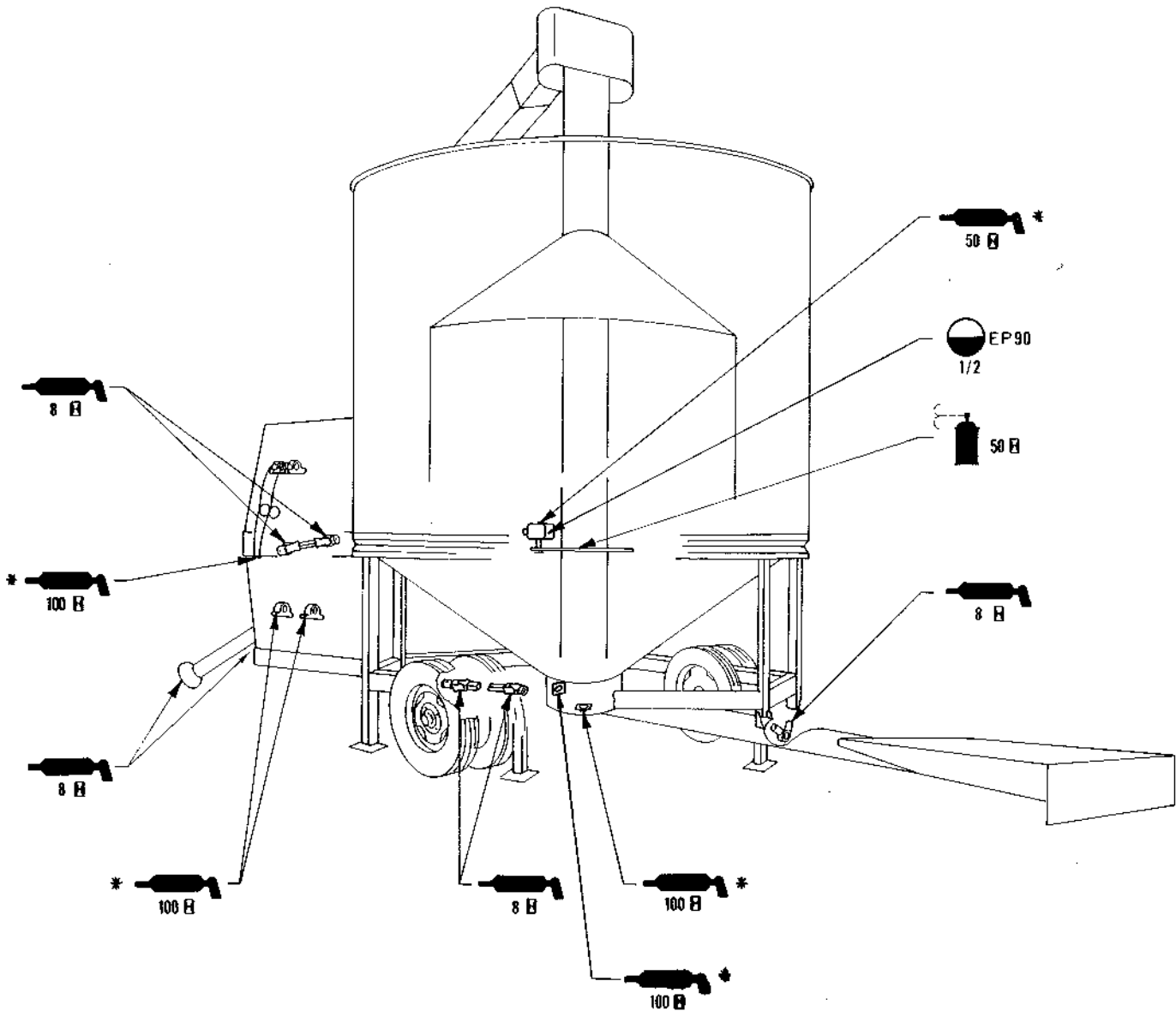

Use a high-low temperature grease or equivalent made especially for ball and roller bearings in extreme temperatures.

Refer to the following chart for location of lubrication points and frequency of lubrication. A small amount of grease at the specified intervals is recommended over a large amount at less frequent intervals.



*These grease points are located at centralized panel. (QF only)

Symbol descriptions:

- | | | | |
|--|--|---|--------------------------|
|  | Grease Point |  | Gearbox Oil Level & Type |
| * H | Lubrication Frequency (Hours of Operation) |  | Dry Film Spray Lubricant |

When performing the 100 hour lubrication, check to see that set screws in bearing and tumblers are tight.

IMPORTANT: In extremely cold weather, it may be necessary to operate the dryer at a low RPM for a short period of time to allow the grease in the bearings to warm up.

9. SERVICING AND CARE OF AGITATOR

It is important that the agitator be inspected before and after the first load. Then after each 100 hours of operation.

- A. The tapered agitator rollers must support the plate sprocket so there is no horizontal movement of sprocket.

The dryer has four rollers mounted on the agitator sprocket so each roller supports an equal load. These rollers are tapered so all horizontal and vertical slack may be taken up.

B. Adjusting Rollers

1. Secure the cam nut and loosen the bolt.
2. Rotate the cam nut counter-clockwise (when looking down into the cam nut) while holding the bolt stationary.
3. Secure the cam nut and tighten the bolt.
4. All cam nuts must be rotated an equal amount so the agitator sprocket remains true.
5. Rotate agitator arms by hand and check clearance.

NOTE: Agitator drive chain is provided with a spring loaded idler, however, it is necessary to periodically check the chain slack.



DANGER

Do not open inspection door or enter machine while in operation. Failure to do so may result in serious injury or death.

10. BELT TENSION

With machine running at normal speed, belts should be tight enough to keep out the slack. Keep belts tight to prolong life.

11. VAPORIZER (Propane Only)

The vaporizer is designed for year round operation. However, the temperature of the vapor controls (pressure regulator, solenoid valves, ball valve, etc.) can be adjusted by moving the vaporizer ring up or down relative to the burner ring. The controls will run warmest with the vaporizer ring directly in line with the burner ring. By loosening the vaporizer bracket from the burner, the vaporizer can be slid up or down to cool the controls. The temperature of the vapor controls can also be adjusted by moving the vaporizer ring closer or farther from the burner by changing the position of the vaporizer on the burner in the clamp. The vapor plumbing under normal conditions should be operating at a temperature of approximately 120F to 140F. The temperature may be checked by placing your bare hand on the plumbing and will range from warm to hot.

If the vaporizer has been overheated causing possible rupture you will be unable to control the plenum temperature. Check propane tank for liquid withdrawal. Vapor withdrawal will cause over-heating of the vaporizer and possible damage to the controls.

12. CHECK OUT — BEFORE LOADING

All piping and burners have been checked and test fired at the factory. It is possible, however, that some of the connections may have been loosened or damaged during shipment. After connecting supply tank to dryer all connections should be tested under pressure with gas pressure on. Tractor can then be started and dryer test run before loading with grain.



DANGER

Check with liquid soap solution, never with flame. failure to do so may result in serious injury or death.

OPERATING INSTRUCTIONS



Do not operate this machine until you have read and fully understand its safe operation.

1. CONTROLS

This picture shows all components of the control system of the GT Dryer. All parts are numbered and identified by description. The following pages of the Operation, Maintenance and Service sections refer to the following information contained herein.

STUDY THIS INFORMATION. IT WILL GREATLY ASSIST YOU IN THE OPERATION OF YOUR DRYER.

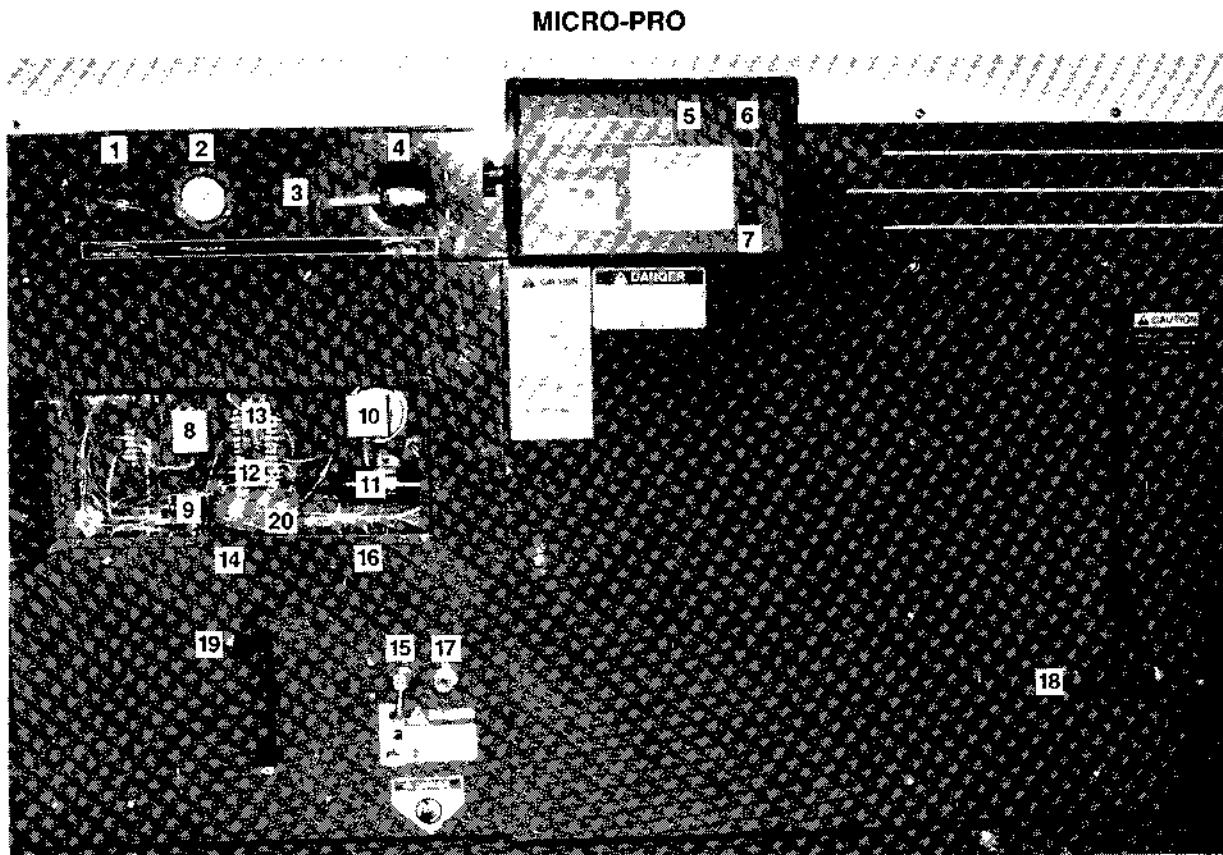

- | | |
|---|---|
| 1. Pressure Regulator | 11. Ignition Coil |
| 2. Pressure Gauge | 12. In-line fuse |
| 3. Solenoid Valves - Vapor
(located directly behind panel) | 13. Terminal Blocks |
| 4. Ball Valve | 14. Pressure Relief Valve (behind door) |
| 5. Microprocessor Unit | 15. Quick Acting Valve - Propane |
| 6. Indicator Light | 16. Strainer (behind door) |
| 7. Power Switch | 17. Propane Inlet |
| 8. Flame Detector | 18. Fan Clutch |
| 9. Solenoid Valve - Liquid | 19. Loading Hopper Clutch |
| 10. Air Switch | 20. Tractor Leadwire |

THIS PICTURE SHOWS ALL COMPONENTS OF THE CONTROL SYSTEM OF THE GT DRYER. ALL PARTS ARE NUMBERED AND IDENTIFIED BY DESCRIPTION. THE FOLLOWING PAGES OF THIS MAINTENANCE AND SERVICE BULLETIN REFER TO THE INFORMATION CONTAINED HEREIN.

STUDY THIS INFORMATION. IT WILL GREATLY ASSIST YOU IN THE OPERATION OF YOUR DRYER.

NON MICRO-PRO

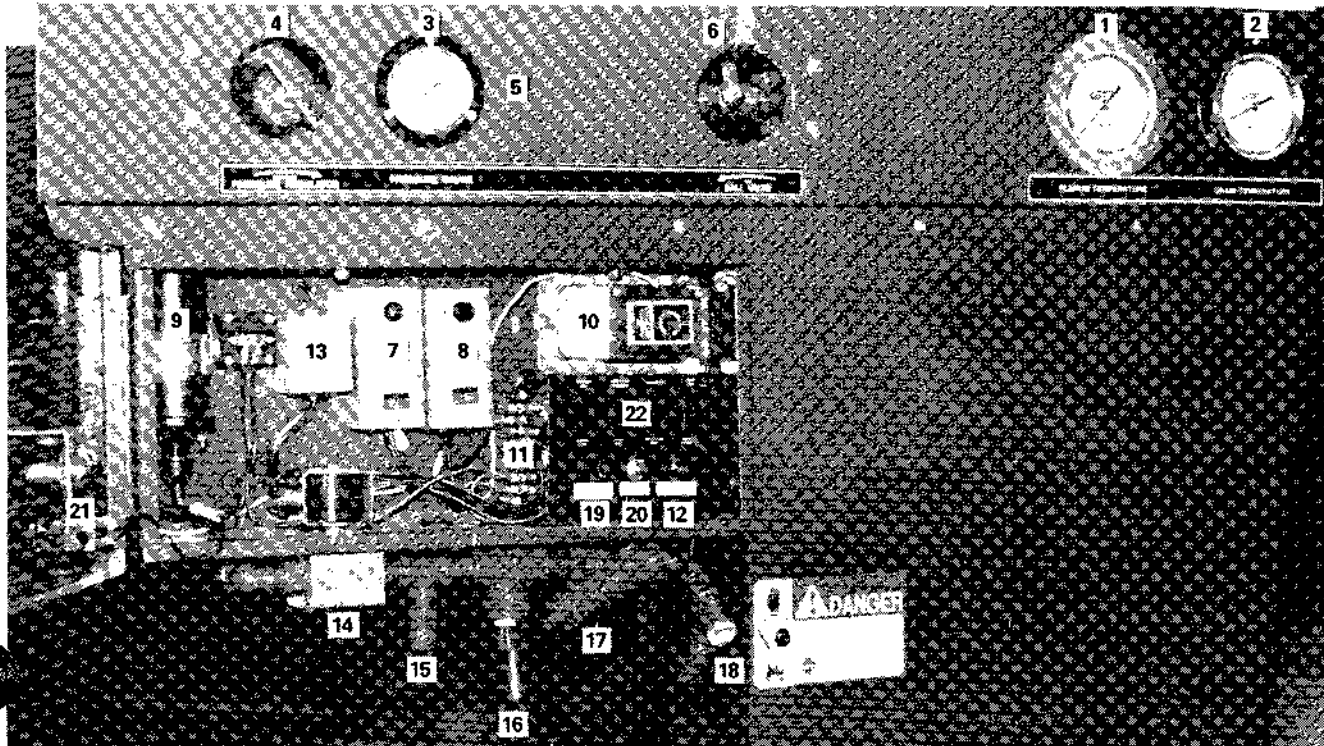

- | | | | |
|-----|---|-----|------------------------------|
| 1. | Plenum Thermometer | 12. | On-Off Switch (Power Switch) |
| 2. | Grain Thermometer | 13. | Flame Detector |
| 3. | Pressure Gauge | 14. | Solenoid Valve - Liquid |
| 4. | Pressure Regulator | 15. | Pressure Relief Valve |
| 5. | Solenoid Valve — Vapor
(located directly behind panel) | 16. | Manual Valve - Propane |
| 6. | Ball Valve | 17. | Strainer |
| 7. | Plenum Control | 18. | Propane Inlet |
| 8. | Grain Control, Temperature | 19. | Fuse |
| 9. | Ignition Coil | 20. | Start Switch |
| 10. | Air Switch | 21. | Panel Light |
| 11. | Terminal Block | 22. | Indicator Lights |

2. PLENUM HIGH LIMIT CONTROL

The high limit control safeguards against excessive plenum temperatures. The maximum temperature is factory set and microprocessor controlled. An additional high limit thermostat is placed in the plenum and acts independently of the microprocessor. If the plenum temperature should exceed the thermostat setting, the thermostat switch will close and the power to the dryer will be shorted, blowing the in-line fuse located inside the junction box. Before drying can be resumed, this fuse must be replaced.

3. LOADING THE BIN

NOTE: The fan clutch can be disengaged during loading and unloading of dryer to lower the energy requirement. It also reduces the amount of dirt and dust which is blown out of the dryer during the load and unload cycle.

When the loading hopper attachment is used for filling the dryer, follow these steps to prevent the grain from being fed into the dryer faster than the vertical auger can recirculate it. When this happens the grain can build up in the bottom of the dryer until it gets into the agitator assembly and causes damage to the agitator.

- A. Make sure that the vertical auger drive belt is kept tight and is not slipping.
- B. Make sure the discharge holes at the top of the vertical auger housing are completely open with the swivel head in the recirculating position.
- C. Make sure that the bottom auger well is kept clean of trash or fine material build up which restricts the flow of grain into the intake of the vertical auger.
- D. The vertical auger flighting cannot be worn down at the intake end.
- E. Slow down the PTO speed to approximately 450 RPM when filling the dryer with lightweight grains such as sunflower seeds, oats, etc.
- F. Set the grain flow regulator in the loading hopper down $1\frac{1}{2}$ " as shown in the drawing. See. Figure A.

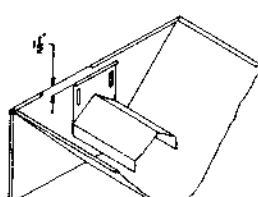

Figure A

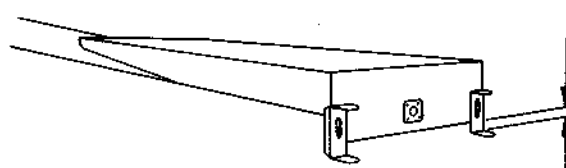

Figure B

- G. Adjust the loading hopper feet so they touch the ground as the loading auger becomes fully engaged with the drive portion of the auger. See Figure B.



DANGER

Make certain that the auger intake is free of debris and that everyone is clear before engaging the loading auger. Failure to do so may result in serious injury or death.

- H. Slowly engage loading hopper clutch. See Figure 19 on page 16.
- I. Fill the grain bin until the grain level is approximately 5 to 10 inches below the top ring. This amount depends on initial grain moisture. As wet grain is heated it will expand. Leaving a couple of inches at the top provides the additional room needed and prevents the dryer from spilling over. Disengage the loading auger when the bin is full.

DO NOT LEAVE GRAIN IN DRYER OVERNIGHT. Grain that remains in the dryer overnight will absorb moisture and swell. This swelling can cause the vertical auger to cease.

When the loading attachment is not used, overhead bins or a conventional farm type elevator or auger may be used. In using any method of filling from top, make delivery of grain into dryer as near to center as possible. Start machine, without burner, at the same time loading begins. This helps keep bin loaded evenly. Bin will fill to rim and pyramid evenly to auger outlet.

4. BURNER STARTING INSTRUCTIONS (MICRO-PRO)

- A. Connect electrical lead in wires. Power take-off machines have as standard equipment a 12 VDC negative ground control circuit. It is important that the lead in wires be properly connected to the tractor battery. Red clip to the hot (+) side of the battery and black clip to the ground (—) side of the battery. An improper connection may cause the in-line fuse, located in the junction box, to blow. For proper battery connections see page 12.
- B. The fan should be at operating speed. This can be obtained by an approximate PTO speed of 525 RPM.
- C. Open shut-off valve at the fuel tank and the ball valve and quick acting valve at the dryer. The pressure regulator handle should be screwed counter-clockwise until the handle turns freely, thus closing the regulator, then turn one full turn clockwise.

NOTE: Instructions D through L, except I, refer to the microprocessor unit.

IMPORTANT: The burner may be stopped at any time by pressing the "STOP" key.

- D. Place the power switch in the "ON" position. The microprocessor will check the applied voltage. If the polarity or voltage is incorrect, no further operation will occur. If the voltage is low, between 7 and 11 volts, "VOLTS LOW" will flash in the display. If the voltage is high, greater than 18 volts, "VOLTS HIGH" will flash in the display.

When the voltage is correct, between 11 and 18 volts, the PTO speed will be measured. If it is too low, less than 350 RPM, "PTO LOW" will appear in the display and the Indicator Light will light. If the PTO speed is too high, greater than 540 RPM, "PTO HIGH" will appear in the display and the Indicator Light will light. Further operation will not be allowed until the PTO speed has been corrected.

When both the voltage and the PTO speed are correct, the total elapsed operating time since manufacture will appear on the display.

- E. Press "GRAIN" key. To select the grain which is to be dried, press the "UP" or "DOWN" key until the desired grain appears on the display. The grains stored in the microprocessor memory are listed in alphabetical order as follows:

Barley	Rape
Barley Seed	Rape Seed
Corn	Rough Rice
Corn Seed	Rough Rice Seed
Flax	Soybeans
Flax Seed	Soybeans Seed
Grain Sorghum	Sunflower — Bird
Grain Sorghum Seed	Sunflower — Oil
Oats	Wheat
Oats Seed	Wheat Seed

- F. Press "Plenum Temp" key. The preset plenum temperature will appear on the display as, for example, "PTEMP 220 + 0". The 220 represents the preset plenum temperature for the selected grain. If desired, the preset temperature can be adjusted by pressing the "UP" key to raise or the "DOWN" key to lower the plenum temperature. The change will appear on the display as, for example, "PTEMP 240 + 20" where the + 20 represents a setting 20 degrees above the preset plenum temperature. A -20 would represent a setting 20 degrees below the preset plenum temperature.
- G. Press "GRAIN TEMP" key. The preset grain temperature at which shut-down occurs will appear on the display. Again, if desired the present temperature can be adjusted by pressing the "UP" key to raise or the "DOWN" key to lower the grain temperature as in Step F.
- H. Press "START" key and hold until "FLAME" disappears from the display. If the 16 second purge delay had not elapsed, the alternating time and grain temperature display will continue. After the purge delay has elapsed, "FLAME" will appear on the display as ignition attempts begin. Up to 5 PSI gas pressure may be required for ignition. If the "START" key is released before the "FLAME" indication has been removed, shut-down will occur. The purpose of the purge period is to clear the plenum of any unburned fuel.
- If ignition does not occur within 90 seconds, the gas valves will close and ignition attempts will cease. Any further attempts to start the burner must begin with the "GRAIN" key as in Step E.
- I. Forty five seconds after ignition, the high heat solenoid will open allowing maximum burner output. The gas pressure should now be gradually increased to 20 — 25 PSI. If frost appears on the line wait a few minutes before increasing the pressure further. "PRUN LOW" will appear on the display until the plenum reaches 115 degrees Fahrenheit.
- J. After ignition four displays are possible; PLENUM TEMP, GRAIN TEMP, and an alternating display with the running plenum temperature, PRUN, and running grain temperature, GRUN. GRUN indicates the difference between the current grain temperature and the setting determined in Step G. PRUN indicates the difference between the current plenum temperature and the setting valve determined in Step F.

The PLENUM TEMP or GRAIN TEMP mode can be produced by pressing its respective key. In this mode the set point for either the plenum or the grain temperature may be adjusted while the dryer is in operation.

To again produce the alternating PRUN — GRUN mode, press the "CHECK" key.

- K. The dryer will continue to operate until some condition causes it to cease. Regardless of the cause, except for power failure, the error condition which ended operation will appear on the display after shut-down has occurred. The Indicator Light will also light. Shut-down will most commonly occur when dry-down has been completed. "GRAIN" will appear on the display.

The other possible error conditions are listed below. If one or more safety related failures are present, the failure with the highest priority will be displayed. No further action will be allowed and the operator must return to Step E to restart the burner. The possible error conditions are:

PRIORITY	ERROR CONDITION	DISPLAY
1	Voltage low Voltage high	VOLTS LOW VOLTS HIGH
2	PTO speed low PTO speed high	PTO LOW PTO HIGH
3	Extreme plenum temperature	PLENUM
4	Loss of auger motion	AUGER
5	Loss of agitator motion	AGITATOR
6	Loss of air low	AIR
7	Flame out	FLAME
8	Transient	TRANSIENT
9	Reached grain set point	GRAIN

On occasion, the unit may stop with the display "TRANSIENT". This indicates that an error was detected but disappeared before it could be identified. An example of this would be a belt slipping.

In all cases the Indicator Light will light to note that operation has ceased. The light may be turned off by pressing any key on the key board. The burner may be stopped at any time by pressing the "STOP" key. The Indicator Light will not light in this case.

- L. It is possible to monitor the grain temperature through the cool down cycle by simply pressing the "CHECK" key. The present grain temperature and the total elapsed time since manufacture will alternate on the display.

STARTING THE BURNER - **NON MICRO**

- A. Fan should be at operating speed. This speed can be obtained by approximately 525 RPM PTO speed, however, a lower fan and PTO speed is recommended in some conditions.
- B. Check the Plenum and grain temperature controls in the control box for proper setting. (Refer to instructions in this manual.) Re-set the controls if necessary.
- C. **NOTE:** For other than initial starting, skip to step H and continue.
For initial starting, the ball valve and quick acting valves should be open, and the high pressure regulator handle should be turned out (counter-clockwise) until the screw turns freely, then turn back in (clockwise) one full turn.
- D. Move power switch to the "on" position. Depress and hold burner start switch, and at the same time turn the regulator screw clockwise until burner lights. Hold start switch depressed until flame detector is activated, usually 20 to 30 seconds.
- E. If frost should appear on the gas lines wait 2 to 3 minutes to allow the vaporizer to heat before increasing the gas pressure.
- F. Gradually increase the plenum temperature by screwing the pressure regulator handle in (clockwise). If frost appears on the line at any time wait a few minutes before increasing pressure further. Continue to increase the gas pressure until the plenum temperature is at least 10°F above the desired operating plenum temperature. **NOTE:** In extreme temperature changes, it may be necessary to go more than 10°F above the desired plenum temperature.

- G. For restarting the burner it is not necessary to change the setting of the pressure regulator unless a different plenum operating temperature is desired. Simply turn the ball valve handle so that it is only partially (one quarter) open. Open the quick acting valve.
- H. Move power switch to the "on" position. Depress and hold burner start switch, and at the same time turn the regulator screw clockwise until burner lights. Hold start switch depressed until flame detector is activated, usually 20 to 30 seconds.
- I. After flame is established gradually open the ball valve until completely open. NOTE: Opening the ball valve too rapidly may cause frost to form in the gas lines.

5. RESTARTING THE BURNER AFTER SHUT-DOWN OR IGNITION FAILURE **(MICRO-PRO)**

- A1. If operation was stopped by the "STOP" key or if the grain temperature reached the set point, dry-down complete with "GRAIN" appearing on the display, the dryer may be restarted by pushing the "START" key. See Step H above. The PLENUM TEMP and GRAIN TEMP functions will retain their most recent settings.
- A2. If operation was stopped by an error condition, correct the error, then begin the restarting attempt with the "GRAIN" key. See Step E above. This clears all previous PLENUM TEMP and GRAIN TEMP inputs.
- B. Complete the starting instructions beginning with the appropriate step as indicated in Step A1 or A2.

6. WHEN TO TURN BURNER OFF UNDER NORMAL OPERATING CONDITIONS **(MICRO-PRO)**

The burner can be extinguished either manually with the "STOP" key or automatically with the microprocessor when the grain reaches the desired degree of dryness. This can be determined by the use of a moisture tester. Allow the fan to run until the grain cools to about 20 degrees above the outside temperature or 10 degrees above grain in storage. Grain will dry as much as 1 — 2% during the cooling period, depending on the relative humidity. The grain temperature can be monitored on the display through cool down by pressing the "CHECK" key.

7. UNLOADING

After the grain has cooled, swing the unloading spout to the unloading position if the dryer is equipped with the standard swivel head or engage the hydraulic motor if equipped with the horizontal unloading head.

8. DRYER NOT IN USE

When the dryer is not in use, the quick acting valve under the control panel and the power switch must be in the "OFF" position. The supply line should also be shut off at the tank. If location is such as to permit traffic of livestock between dryer and supply tank, protection of the supply line is a must.

NOTE: When shutting the burner off for an extended period of time (even over night) it is a good safety practice to shut the gas off at the supply tank and let all of the gas in the lines burn out.

9. PLENUM TEMPERATURE RANGES FOR DRYING

MICRO-PRO

GRAIN*	PLENUM TEMPERATURE OPERATING RANGE (degrees F)		PRESET PLENUM TEMPERATURE (degrees F)
Barley	180	— 200	190
Barley Seed	120	— 170	160
Corn	200	— 230	220
Corn Seed	140	— 180	160
Flax	140	— 160	150
Flax Seed	90	— 120	120
Grain Sorghum	230	— 250	230
Grain Sorghum Seed	140	— 180	160
Oats	200	— 230	220
Oats Seed	140	— 180	160
Rape	140	— 160	150
Rape Seed	90	— 120	120
Rough Rice	140	— 160	150
Rough Rice Seed	90	— 120	120
Soybeans	180	— 200	190
Soybeans Seed	120	— 170	150
Sunflower — Bird	110	— 150	140
Sunflower — Oil	110	— 150	150
Wheat	150	— 180	170
Wheat Seed	100	— 150	130

*NOTE: Grains which are not indicated as "Seed", are intended for commercial use or animal feed.

ADJUSTING PLENUM CONTROL

The plenum temperature control is located inside the control box and is used to set the desired drying temperature inside the plenum chamber. Use the above chart as a guide to set the control. The actual plenum temperature will go approximately 5°-10° above or below the specified setting on the control.

10. MAXIMUM GRAIN TEMPERATURE FOR INDICATED USE

GRAIN	PRESET GRAIN TEMP. Micro-Pro (degrees F)		MAXIMUM GRAIN TEMP. (degrees F)		
	SEED	COMM. USE/ FEED	SEED	COMM. USE	FEED
Barley	105	120	105	120	140
Corn	110	130	110	130	140
Flax	105	120	110	120	
Grain Sorghum	110	130	110	140	140
Oats	105	130	105	140	140
Rape	110	120	110	120	
Rough Rice	110	110	110	110	110
Soybeans	105	120	105	120	140
Sunflower — Bird		90		90	
Sunflower — Oil		100		100	
Wheat	105	120	105	120	140

11. ADJUSTING GRAIN TEMPERATURE SETTING - MICRO-PRO (See Step G. Page 20)

The grain temperature setting serves to prevent over-heating of the grain. When the temperature gets to the preset grain temperature the burner will shut off and the Indicator Light will light. Refer to the above chart for maximum grain temperature settings.

To initially set the grain temperature begin with the preset grain temperature setting stored in the microprocessor. NOTE: When drying grain for seed purposes, use the grain setting indicated as "Seed". As the batch is drying, periodically take grain samples from the sampler tube and check the moisture content on an accurate moisture tester. When the grain gets within 1 — 2 percentage points of the desired final moisture content adjust the grain temperature setting down until the gas shuts off thus extinguishing the burner. Let the grain cool to the desired temperature. The grain will continue to dry during the cooling process and should be near the desired dryness after cooling. If the grain is still a little too wet, raise the temperature setting one or two degrees on the next batch. If the grain was a little too dry, lower the temperature setting one or two degrees on the next batch.

When drying grain for seed purposes set the grain setting on "Seed", and begin with the preset value. When the grain in the dryer reaches the preset temperature the burner will be extinguished. Check the moisture content after cool down. If this batch is too wet, LOWER the plenum temperature slightly for the next batch. Lowering the plenum temperature will increase the drying time and therefore decrease the grain moisture. Conversely, if the batch is too dry, RAISING the plenum temperature slightly for the next batch will decrease the drying time and therefore increase the grain moisture. Do not exceed maximum plenum or grain temperatures shown in the charts on page 23.

The grain temperature control serves as an indicator to the degree of dryness, but settings must be ascertained at user level. For recording temperatures used, a sheet is provided in the back of this manual. Each batch should be tested to be sure the proper moisture level is reached. Different varieties of the same grain may require different temperature settings to achieve the same degree of dryness.

ADJUSTING GRAIN TEMPERATURE CONTROL (See No. 8, page 17)

The grain temperature control is located inside control panel and serves to prevent over-heating of grain. When the grain temperature gets above the dial setting the control will shut the burner off and the red grain temperature light will come on. Check periodically. Refer to chart under maximum temperature of grain. (See page 23.)

To initially set the grain temperature control turn the dial setting to about 10° or 20°F above the "commercial use" grain temperature in the following table. (NOTE: When drying grain for seed purposes refer to instructions in next paragraph.) Example: Shelled corn for commercial sale; set dial at 140° or 150°F. As the batch is drying, periodically take grain samples from the sampler tube and check the moisture content on an accurate moisture tester. When the moisture gets within 1 — 1½ percentage points of the desired final moisture content slowly turn the dial on the grain temperature control down until the gas is shut off thus extinguishing the burner. Let the grain cool to the desired temperature. The grain will continue to dry during the cooling process so should be near the desired dryness after cooling. If the grain is still a little too wet raise the temperature control setting one or two degrees on the next batch. If the grain was a little too dry lower the temperature control setting one or two degrees on the next batch.

When drying grain for seed purposes set the grain temperature control at or slightly below the temperature specified in the malt or seed column of the grain temperature chart. The plenum temperature should be set according to the seed column of the plenum temperature chart. When the grain in the dryer reaches the control setting the burner will be extinguished. Check the moisture content of the grain in the dryer. If this batch of grain is too wet, lower the plenum temperature slightly for the next batch. Lowering the plenum temperature will increase the drying time and therefore decrease the grain moisture. Conversely, if the batch of grain is too dry, raising the plenum temperature slightly for the next batch will decrease the drying time and therefore increase the grain moisture. Do not exceed maximum plenum or grain temperature shown in charts.

The grain temperature control serves as an indicator to degree of dryness, but settings must be ascertained at user level. For recording temperatures used, a sheet is provided in back of this manual. Each batch should be tested to be sure the proper moisture level is reached. Different varieties of the same grain may require different grain temperature settings to achieve the same degree of dryness.

WHEN TO TURN OFF BURNER

The burner can be extinguished either manually by the Off—On switch or automatically by the grain temperature control when the grain reaches the desired dryness. This can be determined by use of a moisture tester. Allow the fan to run until the grain cools to about 20^o above the outside temperature or 10^o above grain in storage. Grain will dry as much as 1% during the cooling period, depending on the relative humidity.

12. ADJUSTMENT OF FUEL—AIR MIXTURE

Your burner is factory set for correct air input for various pressures. Burner will not operate properly unless fan is at the approximate recommended operating speed.

MAINTENANCE SERVICE AND TROUBLE SHOOTING FOR GT GRAIN DRYERS

PROPANE GAS FLOW CHART

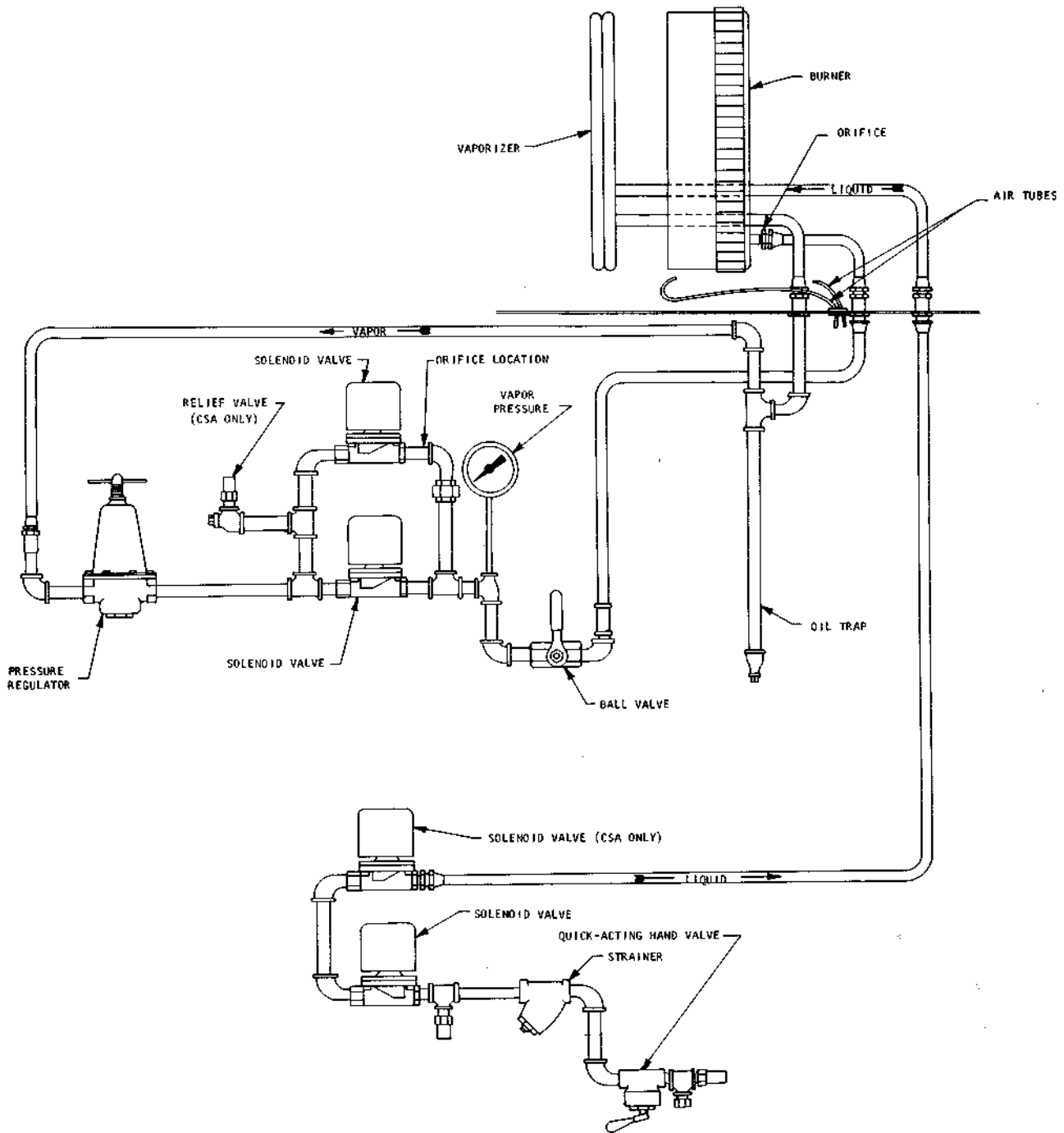

MICRO-PRO SENSOR LOCATIONS

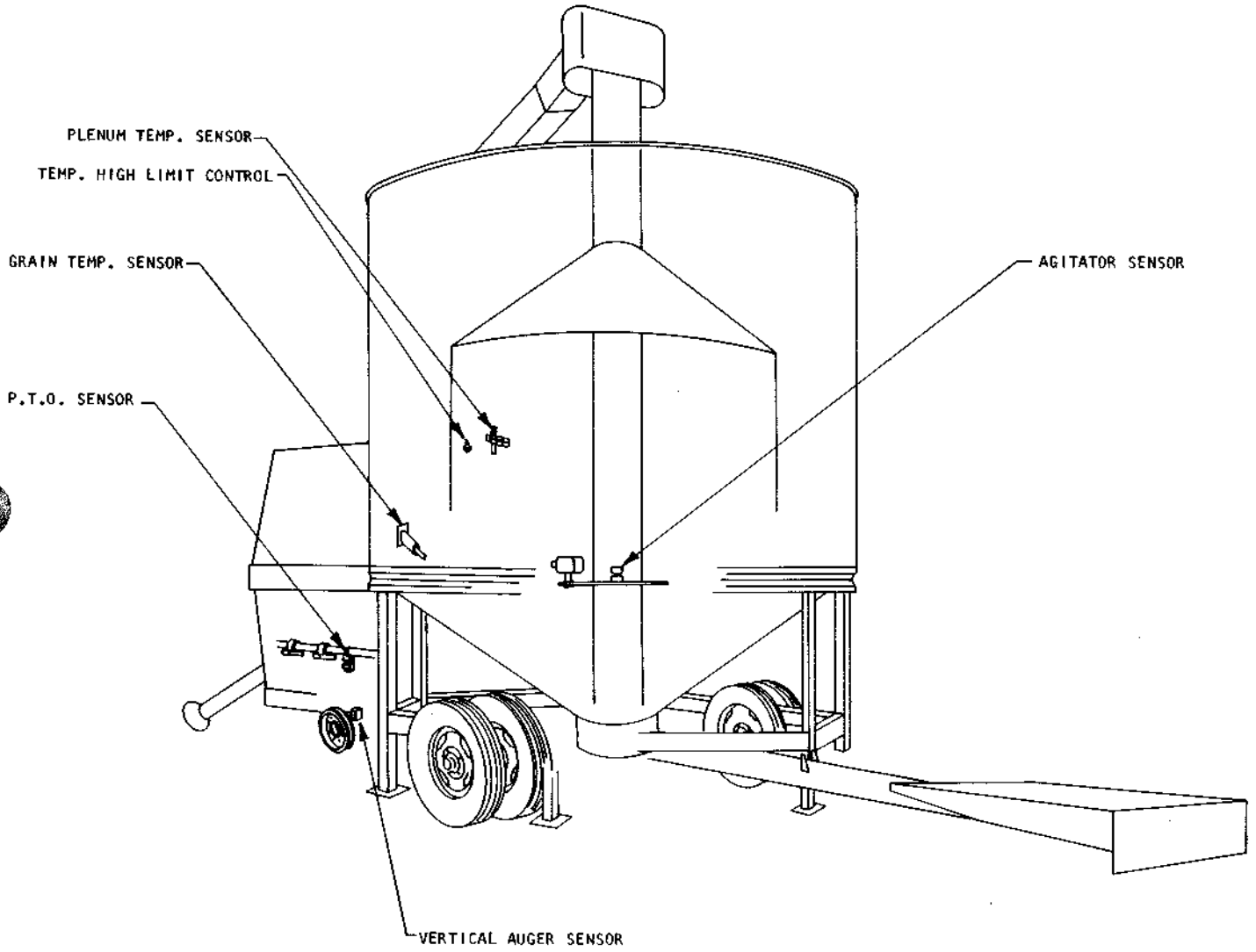

WIRING DIAGRAM - MICRO-PRO

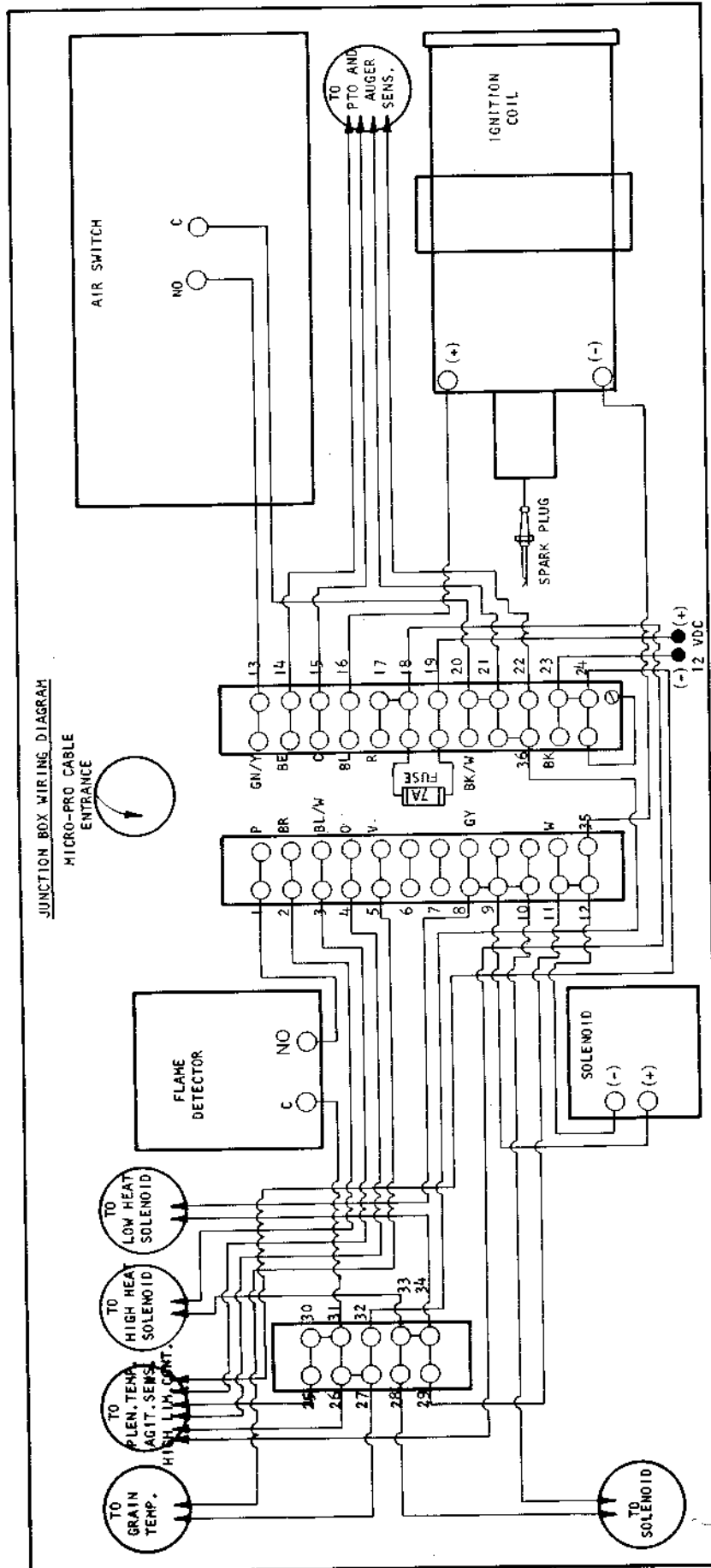

TERMINAL BLOCK KEY - MICRO-PRO

POSITIVE (+) TERMINALS	COMMON (—) TERMINALS
1. Flame Detector (Norm. Open) - Black	12. Liquid Solenoid - Blue
2. High Heat Solenoid - Black	20. Air Switch (Common) - White
3. Agitator Sensor - White/Blue	21. PTO Sensor - White
4. Plenum Temp. Sensor - White/Orange	22. Auger Sensor - Black
5. Grain Temp. Sensor - White/Orange	23. Battery (Negative 12 VDC)
6. Open Terminal	24. High Limit Switch - White/Black
7. Open Terminal	25. Agitator Sensor - White/Black
8. Low Heat Solenoid - Black	26. Plenum Temp. Sensor - White/Black
9. Liquid Solenoid - Black	27. Grain Temp. Sensor - White/Black
10. Liquid Solenoid - Black	28. Liquid Solenoid - Blue
11. Terminal Post 29 - White	29. Terminal Post 11 - White
13. Air Switch (Norm. Open) - Black	30. Open Terminal
14. PTO Sensor - Brown	31. Flame Detector (Common) - White
15. Auger Sensor - Yellow	32. Terminal Post 36 - White/Black
16. Ignition Coil (Positive) - Black	33. High Heat Solenoid - Blue
17. Open Terminal	34. Low Heat Solenoid - Blue
18. High Limit Switch - Orange	35. Ignition Coil (Negative) - White
19. Battery (Positive 12 VDC)	36. Terminal Post 32 - White/Black

ELECTRIC SCHEMATIC

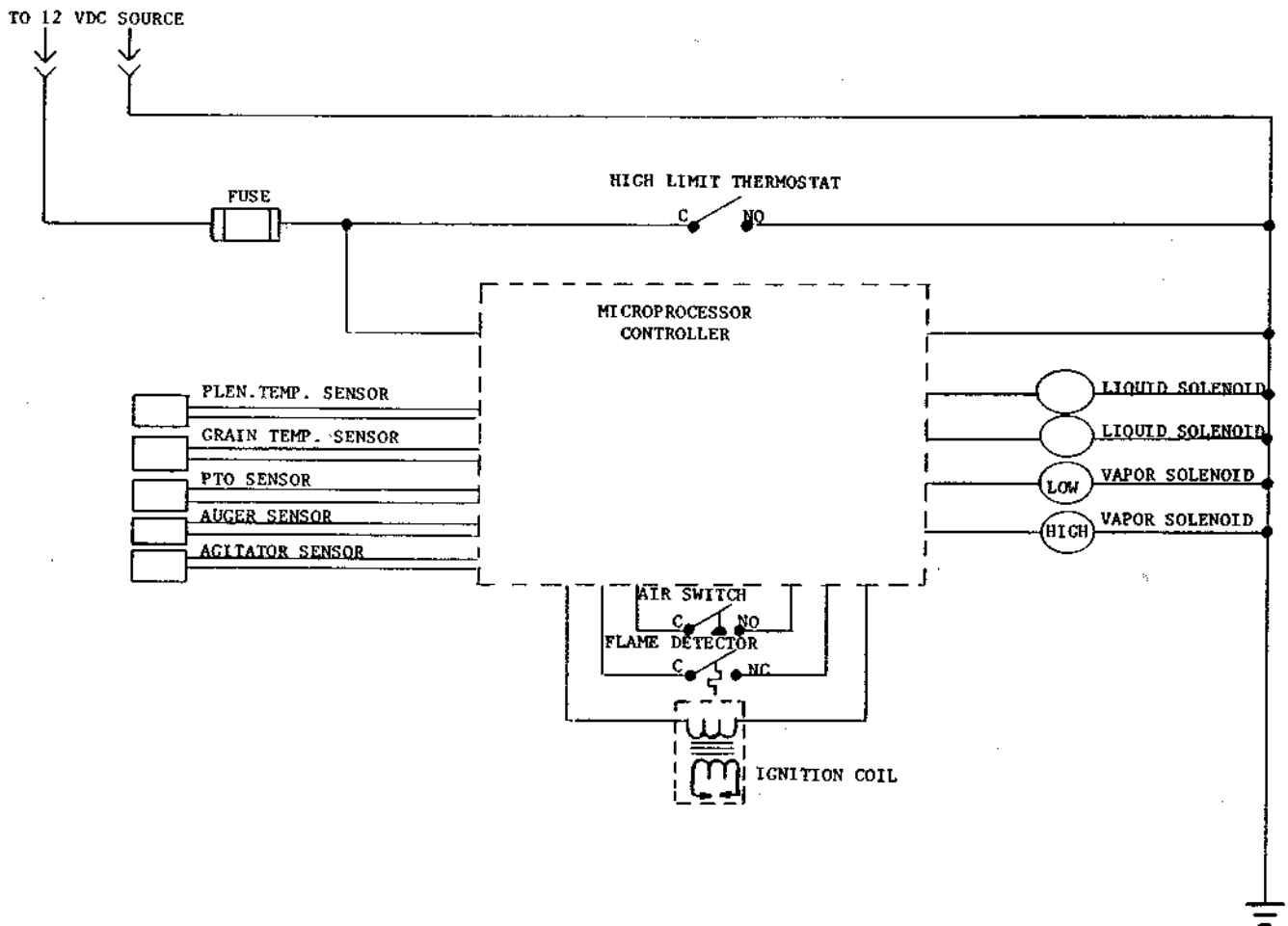

WIRING DIAGRAM - NON MICRO

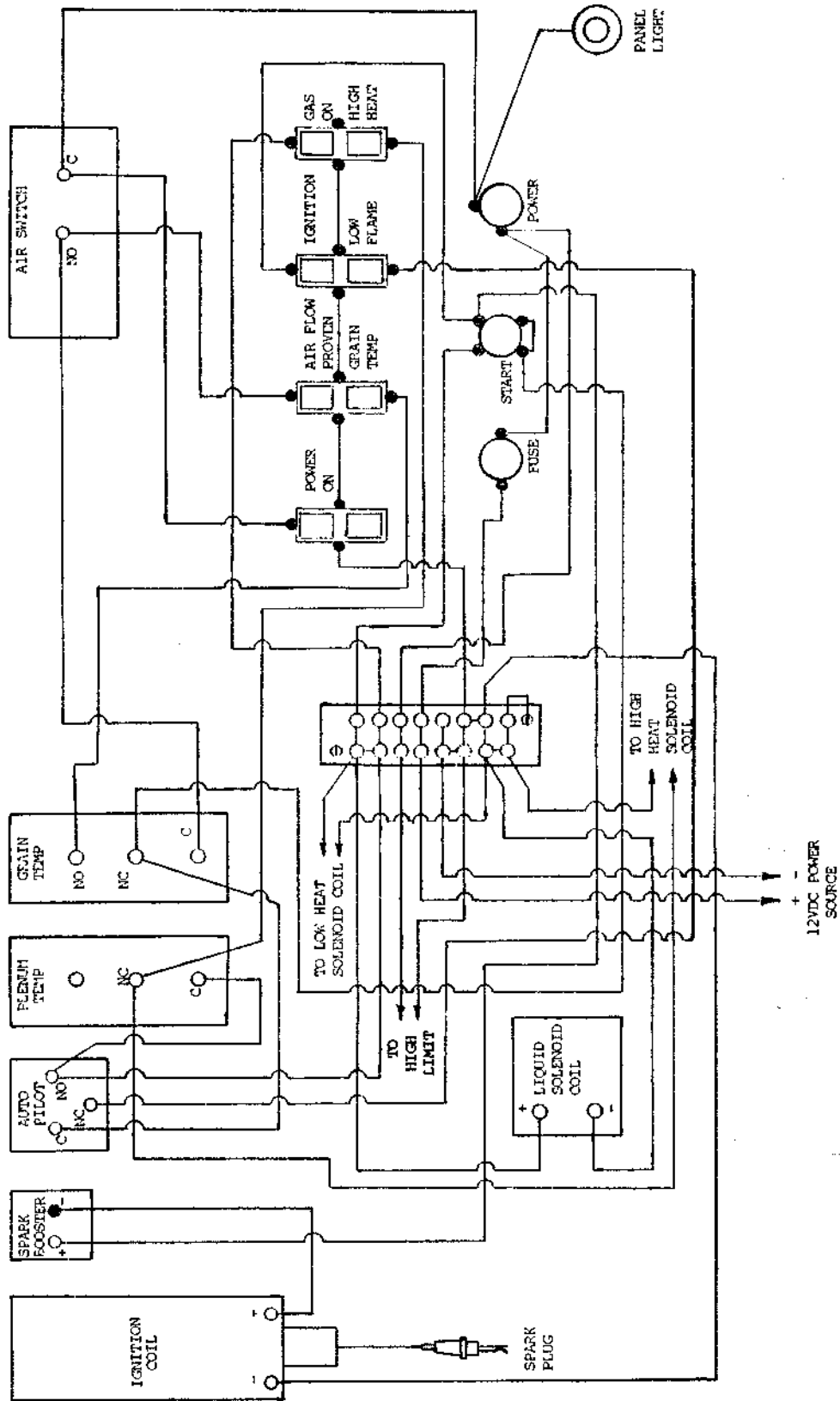

ELECTRIC SCHEMATIC - NON MICRO

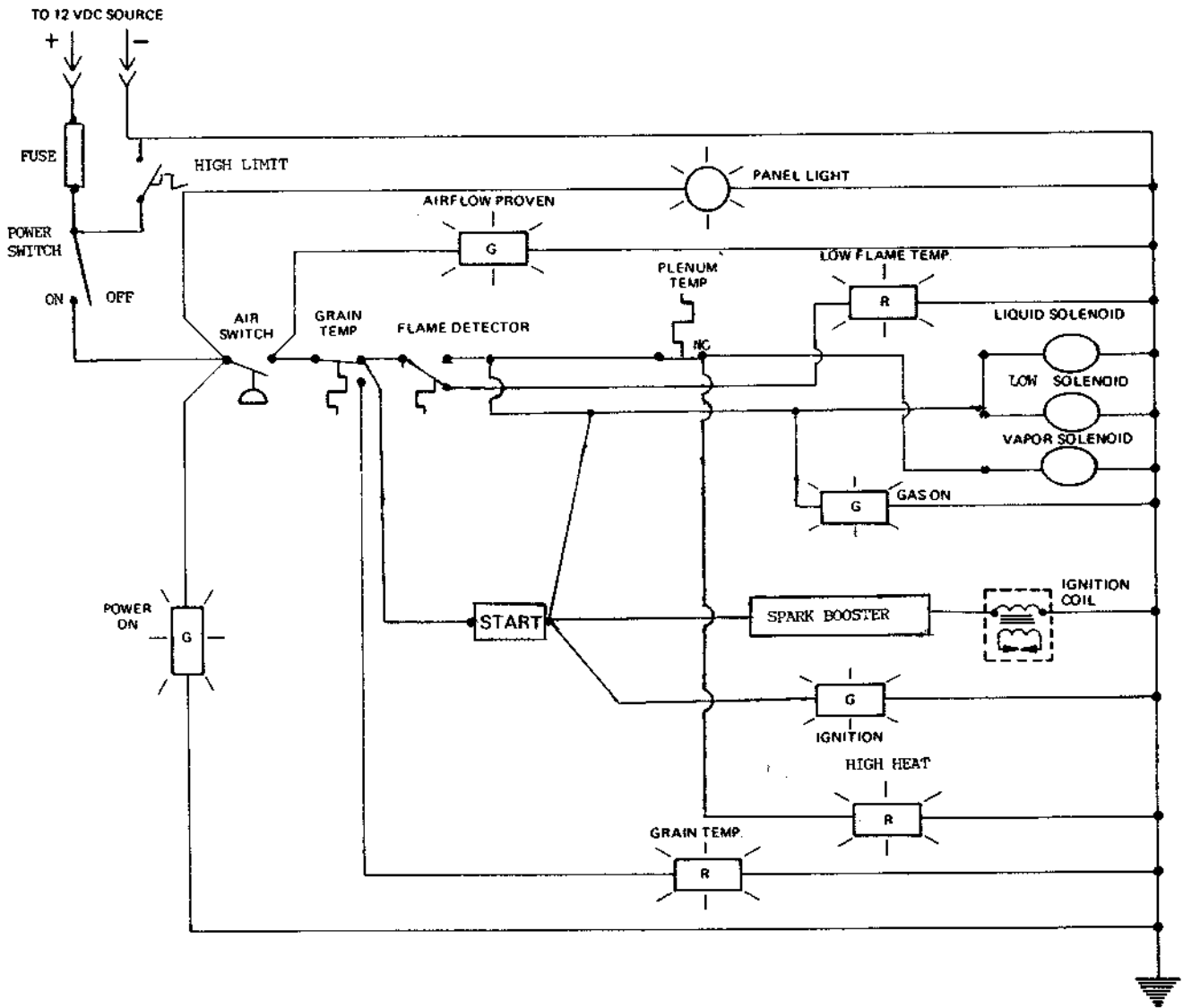

SEQUENCE OF OPERATION MICRO-PRO

With the lead wires connected to the proper power source (12VDC negative ground) and the PTO operating at its recommended speed, the microprocessor unit is ready for operation. Turning the power switch to the "ON" position, the total hours of operation since manufacture and the current grain temperature will alternate on the display.

The drying operation begins by first selecting the drying parameters.

1. Select the grain to be dried from the library of grains listed in the microprocessor.
2. Set the plenum temperature. If necessary, adjust up or down from the preset temperature as it appears on the display.
3. Set the grain temperature. Adjust up or down as required.

The burner is ignited by pressing and holding the "START" key. A 16 second purge period began when the "GRAIN" key was pressed or if there had been a previous unsuccessful starting attempt. If this purge period has not elapsed when the "START" key is pressed, the elapsed time since manufacture and present grain temperature will continue to alternate on the display until the end of the purge period.



After the purge period has elapsed the low heat gas solenoid will open, the igniter will begin to spark, and the word "FLAME" will appear on the display. This indicates ignition attempts are being made and will continue until a flame is sensed.

Once a flame has been detected, the igniter will stop sparking and the word "FLAME" will be removed from the display. The "START" key should now be released. If the "START" key is released before this time burner shutdown will occur. If ignition does not occur within 90 seconds, the low heat gas solenoid will close and ignition attempts will cease.

After ignition has occurred the burner will remain on low heat for 45 seconds to allow sufficient time to insure good vaporization action. The high heat solenoid will then open and the burner will operate at maximum output. This continues until the plenum has reached its preset temperature. At this point the dryer will begin to cycle between the high heat and low heat solenoids maintaining the preset plenum temperature.

The dryer will continue to operate in this fashion until an error is sensed or the grain has reached its dry-down temperature. At this point the burner will be extinguished, ending the heating cycle.

GENERAL OPERATING MAINTENANCE

1. Keep the area clean of shucks, chaff and other combustible foreign material.
2. Keep the fan screen clean.
3. Periodically check the ignition system, all controls and safety shut-off valves for proper operation and gas tightness.
4. Periodically clean the screen in the fuel line strainer.
5. Drain propylene out of oil trap pipe in plumbing weekly.
6. Check all belts for proper tension.
7. Lubricate the machine as outlined on page 14.
8. Make certain dryer weight is evenly supported by jacks.
9. Depending on operating and fuel conditions the burner ports may need to be cleaned periodically. Working from the inside the plenum chamber and using a 5/64" diameter drill bit or torch tip cleaner open up the burner ports.
10.  Keep all safety labels and operating instructions clean and legible. If any label becomes worn, damaged, or illegible, replace it immediately.
11.  Replace all shields/guards removed for service before operating the machine.

REMEMBER: An ounce of prevention is worth a pound of cure!

MICROPROCESSOR AND SENSOR MAINTENANCE

WARNING: DO NOT OPEN THE MICROPROCESSOR ENCLOSURE! There are no owner serviceable components. Service is to be done by authorized personnel only. See your authorized GT dealer.

1. Disconnect the microprocessor unit (see page 13) BEFORE servicing any motion or temperature sensor. Failure to do so may result in permanent damage to the microprocessor.
2. When the dryer is not in use store the microprocessor unit in a cool, dry place free of dust. This will help to insure long, trouble free service from your microprocessor.
3. The correct spacing between the motion sensors and magnets is 0.125 inch. The unit will function properly if the clearance is less than this but should they come into contact the sensors would be destroyed.
4. The temperature sensors are polarized and must be installed properly. See the wiring diagram, page 28 for proper wire locations. Should the wires become reversed, the dryer will not ignite. The sensors are seen as "HOT" and ignition is prevented.

5. It is important to keep your electrical supply to the dryer in peak operating condition. The microprocessor requires 11.5 volts DC to operate properly. A weak battery or tractor alternator can cause the "VOLTS LOW" error indication to appear on the display. Excessively long or light tractor lead cables can cause a similar problem.
6. The spark plug wire used on this machine is a carbon filled cable. If the spark plug wire is ever replaced on the machine it must be of this type. The metal conductor in other types of spark plug wires causes excessive electrical "Noise" which inhibits the operation of the processor.
7. Overheating of the plenum is protected against by two systems, the microprocessor and a thermostat located inside the plenum. Should the thermostat be activated, a fuse in the control box (see page 17) will blow halting operation. This fuse must be replaced before operation can resume.

PREPARING DRYER FOR STORAGE

1. If dryer remains connected to the fuel supply, close the shut-off valve at the tank and the ball valve and quick acting valve at the dryer.
2. Remove the microprocessor. Store in a cool, dry place free of dust.
3. With masking tape or equivalent, seal holes in air switch tube, any openings in the fuel system, and the microprocessor cable end just removed.
4. Open clean out door in bottom well, clean out all grain, leave door open.
5. Remove belts. Store in a cool, dry place.
6. Brush protective coating of oil on chains and belt surfaces of pulleys.
7. Lubricate all bearings. See chart on page 14.
8. Inspect for worn or damaged parts which should be replaced before being used again.



Replace any safety or operating label that has become worn, damaged or illegible.

9. Set jacks to support dryer weight.

PREPARING DRYER FOR USE - OUT OF STORAGE

1. Remove masking tape covering openings.
2. Connect microprocessor control cable and mount microprocessor to the dryer.
3. Replace and tighten belts.
4. Make certain bottom well is clean and close clean out door just prior to using.
5. Lubricate all bearings. See chart on page 15.
6. Close access door.
7. Check burner ports and clean if necessary. See item (9) of General Operating Maintenance.
8. Test fire the burner and check out all controls to make sure they are working properly before grain is added to the dryer.
9. Level dryer and make certain the weight is equally distributed on the jacks.
10. Check safety and operating decals. If any are not legible they should be replaced.

TRANSPORTING THE DRYER



DANGER

Be alert to overhead obstructions and wires. Failure to do so may result in serious injury, electrocution or death. Removal of top auger section is recommended before towing.



CAUTION

OBSERVE THE FOLLOWING RULES WHEN TRANSPORTING THE DRYER.

1. Make certain the hitch pin is securely attached and an alternate hitch safety chain is secured to the dryer and towing vehicle.
2. Do not transport the dryer at speeds in excess of 20 MPH (32 KPH) and comply with any local regulations governing marking, towing and maximum width.
3. Do not transport the dryer after dark or during periods of poor visibility.
4. Maintain proper tire pressure. (Refer to tire manufacturer's recommendations on the sidewall.)
5. Make certain the microprocessor is securely fastened to the dryer. If the dryer is to be towed any distance the microprocessor should be removed from the dryer and safely stored.

TROUBLE SHOOTING

WARNING: CAUTION SHOULD BE EXERCISED WHEN CHECKING CONTROL PANEL. USE VOLT METER OR TEST LIGHT.

WARNING: DISCONNECT THE MICROPROCESSOR BEFORE SERVICING THE ELECTRICAL OR SENSOR SYSTEMS. FAILURE TO DO SO MAY RESULT IN PERMANENT DAMAGE TO THE UNIT.

Reconnect the microprocessor cable and make certain that it is tight before attempting to restart the dryer.

See page 21 for a complete listing of the error messages given on the microprocessor.

Problem A. BURNER WILL NOT LIGHT.

NOTE: The "START" key must be held in until the "FLAME" indication has been removed from the display.

Probable Cause

- * 1. Check the microprocessor display for error message. If given, correct and proceed.
2. Are both tank and dryer fuel valves open?
3. Is power supply properly connected? Must have the red battery clip connected to the hot (+) side of the battery and the black clip connected to the ground (—) side of the battery. Refer to page 12 for proper battery connections.
4. Check that the in-line fuse has not blown.
5. Is the grain temperature above the grain temperature setting?
- * 6. Check to see that the solenoid valves are opening. With the fan at operating speed flip the power switch to the "ON" position and proceed with the starting instructions. When "FLAME" appears on the display the solenoid valves should open. If the valves open there should be a pressure reading on the pressure gauge.

NOTE: There is a built in 16 second purge delay from the time the "GRAIN" key is pressed until the valves open as ignition attempts are made.

- * 7. Display returns to "HOURS" just as "FLAME" appears on display. Attempt to restart the dryer carefully watching the display. If insufficient voltage is being applied to the dryer, the error message "VOLTS LOW" will very briefly flash on the display and then "HOURS" will appear.
- 7A. Check to see that both solenoid gas valves are opening. With fan at operating speed, or with air switch jumpered, flip the "power" switch to "on" and watch pressure gauge. If valves open there should be a pressure reading.
8. Air switch not closing ("AIR" displayed on screen)* or Air Flow Light. Remove and clean or replace air switch tube.
9. Check for plugged orifice.
10. Possible loose wire connection.
11. Gas pressure too low. Up to 5 PSI for ignition may be required for propane.
12. Gas pressure too high. 30 PSI is near maximum for ignition with propane burner. If gas pressure above 30 PSI are encountered, check the 5/64" diameter burner ports for signs of plugging and clean them out if necessary.
13. System improperly grounded. Check lead wire connections at terminal block.
14. Check plug for spark. If no spark check the following after disconnecting power to the system.
 - a. Check spark gap. Gap should be 3/32" + or — 1/32". If plug is carboned at the points, clean and replace after checking gap.
 - b. Check high voltage lead wire for cracks or breaks, and replace if necessary.
 - c. Check that the high voltage lead wire is not too close to a metal surface to insure that arcing will not occur at any point other than across the high voltage electrode at the ignitor.
15. Check the fuel strainer.

* For Micro-Pro Only

Problem B. BURNER LIGHTS BUT PRESSURE WILL NOT EXCEED 5 TO 6 PSI AND/OR HAS EXCESSIVE FLUTTERING.

Probable Cause

1. Vapor solenoid malfunctioning.
Solution:
Disassemble solenoid body and remove diaphragm. If diaphragm is oily or dirty, wipe clean and replace. If diaphragm is ruptured replace with new diaphragm.
2. Pressure regulator malfunctioning.
3. High Heat solenoid is not opening. Check wire connections. If still does not open, disassemble and clean solenoid valve.

Problem C. BURNER IGNITES BUT GOES OUT DURING OPERATION

Probable Cause

1. Electrical connection may be loose.
2. Worn insulation or wet wires may be grounding.
3. Excessive flow valve at tank may be closing.
4. Check for stoppage in air switch tube. ("AIR" indicated on display)* Green Air Flow Light not on. Remove tube from swith and clean or replace.
5. The flame detector bulb is not sensing flame at the burner* or Red low Flame Light on. (The flame detector must sense enough heat from the flame to close its contacts before the 90 second ignition period has elapsed.) If the flame detector is not closing it will be necessary to adjust the sensor bulb mounted to the burner so that it picks up more heat form the flame. To do this adjust the bulb so that it protrudes into the burner 3/8" to 1/2". Do not over-tighten the locking nut on the flame detecting bulb.
6. Inaccurate plenum temperture sensor. "PLENUM" appears on the display.*
7. Check in-line fuse, if blown check hi-limit switch.

Problem D. UNCONTROLLABLE HEAT.

Probable Cause

1. Cracked Vaporizer.
2. Ruptured gas line.

Problem E. TRASH OR GRAIN FIRE.

Probable Cause

1. Excessive plenum temperature.
2. Trash build-up in plenum.
3. Poor circulation due to agitator being out of operation or adjustment.
4. Ruptured gas line or vaporizer.
5. Improper burner and baffle adjustment.

Solution:

- a. Shut off gas supply.
- b. Disengage fan clutch and continue to circulate grain in machine or empty machine if necessary.

Problem F. GAS WILL NOT SHUT OFF IMMEDIATELY WHEN POWER IS SHUT OFF.

Probable Cause

1. Perforated diaphragm in vapor solenoid valve.
2. Plunger upside down on vapor solenoid valve.
3. Lack of diaphragm in vapor solenoid valve.

* For Micro Pro Only

Problem G. AGITATOR DRIVE CHAIN OFF



DANGER

Do not open inspection door or enter machine while in operation.

Probable Cause

1. Roller stuck — seized bearing — may be flat on one side.
2. Too much horizontal play between agitator race and rollers.
3. Agitator drive sprocket out of line.
4. Too slack a chain.
5. Excess feeding of loading auger causing grain level to rise above agitator. (Close grain flow regulator slightly to reduce feed rate.)

Problem H. AUGER STOPPAGE

Probable Cause

1. Slack belt.
2. Block of wood or rock lodged between auger flight and housing.
3. Extremely wet grain standing over night.
4. Bottom auger bearing frozen.

Problem I. EXCESSIVE DRYING TIME

Probable Cause

1. Plenum temperature too low for conditions.
2. Inaccurate plenum temperature sensor.
3. Poor circulation of grain.
4. Dirty or trashy grain.
5. Hard to dry variety. (Thick seed coat.)
6. Incorrect fan speed.
7. Adverse weather conditions.
8. Recirculation of exhaust air from dryer back into plenum.

Problem J. POOR GRAIN CIRCULATION

Probable Cause

1. Fan speed above that recommended.
2. Build up of foreign material, especially in bottom section of dryer.
3. Agitator not operating. ("AGITATOR" indicated on the display.)

MICROPROCESSOR CONTROL SYSTEM

See page 21 for a complete listing of the error messages given on the microprocessor.

WARNING: DISCONNECT THE MICROPROCESSOR BEFORE SERVICING THE ELECTRICAL OR SENSOR SYSTEMS. FAILURE TO DO SO MAY RESULT IN PERMANENT DAMAGE TO THE UNIT.

Reconnect the microprocessor cable and make certain that it is tight before attempting to restart the dryer.

1. **Low Voltage:** The microprocessor requires 11.5 volts DC to operate properly. If this is not available, operation will cease at that point and "VOLTS LOW" will flash on the display.

Probable Cause:

- A. Lead wires from tractor to dryer too long.
 - B. Lead wires too light of a wire gage.
 - C. Battery weak.
 - D. Tractor alternator weak.
 - E. A loose or poor connection.
2. **Rotational Sensor Failure:** The microprocessor may indicate an error even though the component (Auger, Agitator, PTO) seems to be functioning properly.

DISCONNECT THE MICROPROCESSOR BEFORE SERVICING MOTION SENSORS!

Probable Cause:

- A. Sensor failure. To check the switch, line up the sensor and the magnet then using a volt meter or continuity tester, see if there is continuity across the corresponding lugs on the terminal block. There should be a signal. Now rotate the magnet a quarter turn past the sensor and check the continuity again. If everything is working properly there should be no continuity.
 - B. Sensor out of adjustment. There should only be 0.125 inch between the magnet and the rotational sensor. Distances greater than this will give a weak signal and may not activate the sensor.
 - C. Loose or poor connections at either the terminal block or the sensor connection.
3. **Spark Plug Wire:** Should the spark plug wire become damaged and need to be replaced it is important that a carbon filled cable and not a solid wire conductor be used. A wire conductor will cause excessive electrical "Noise" inhibiting the operation of the machine.
 4. **Inaccurate Temperature Readings:**

Probable Cause:

- A. Loose or poor connection.
- B. Wires hook up backwards. The temperature sensor wires are polarized and must be hooked up correctly. See wiring diagram on page 28.
- C. Temperature sensor failure:
 1. If the sensor shorts out, the microprocessor will see this as an extremely cold condition and will try to bring the temperature up. "PLENUM LOW" will appear on the display if the plenum sensor fails.
 2. If the sensor opens, the microprocessor will see this as an extremely hot condition and shut the dryer down. If the plenum sensor fails "PLENUM" will appear on the display. "GRAIN" will appear if the grain sensor fails.
 3. If the sensor falls out of calibration a faulty temperature will be given. This should be detectable by observation. If the plenum can not achieve the preset value, check the plenum temperature sensor. If the microprocessor says the grain is dry and the grain is still cold check the grain temperature sensor.

**ASSEMBLY DRAWINGS
AND
PARTS LISTS**

POWER UNIT ASSEMBLY (QF)

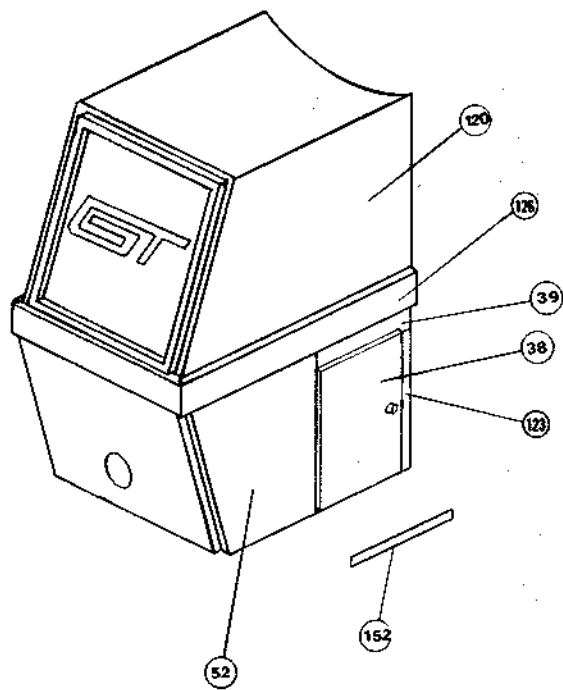
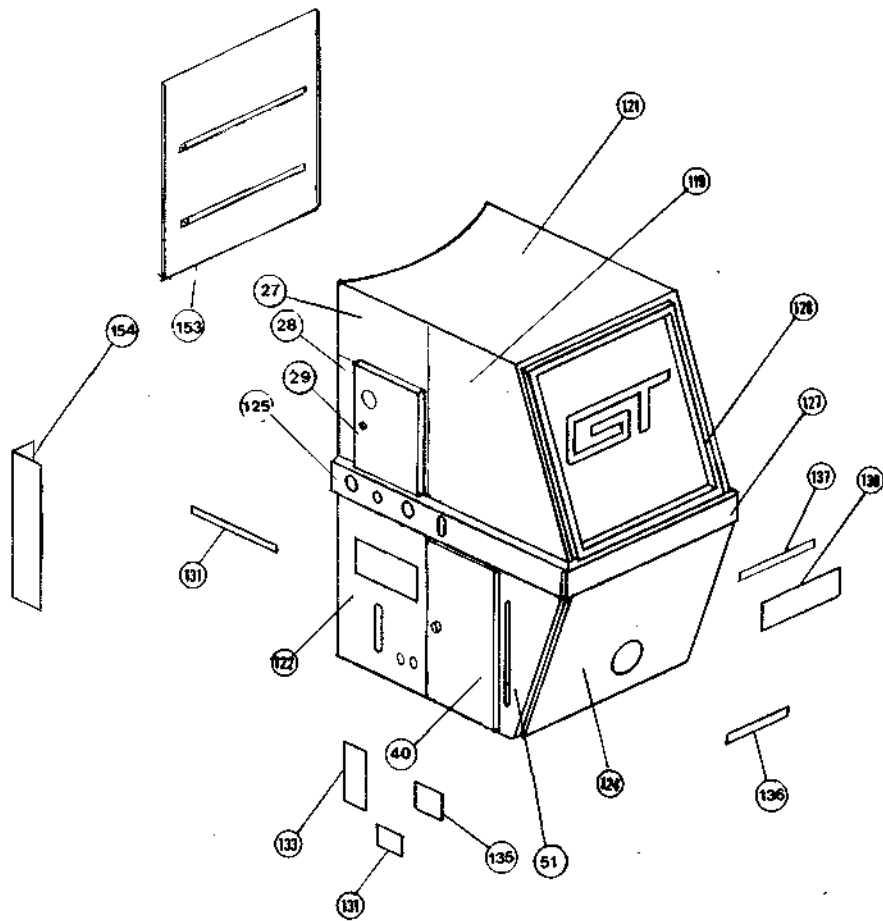

POWER UNIT ASSEMBLY (QF)

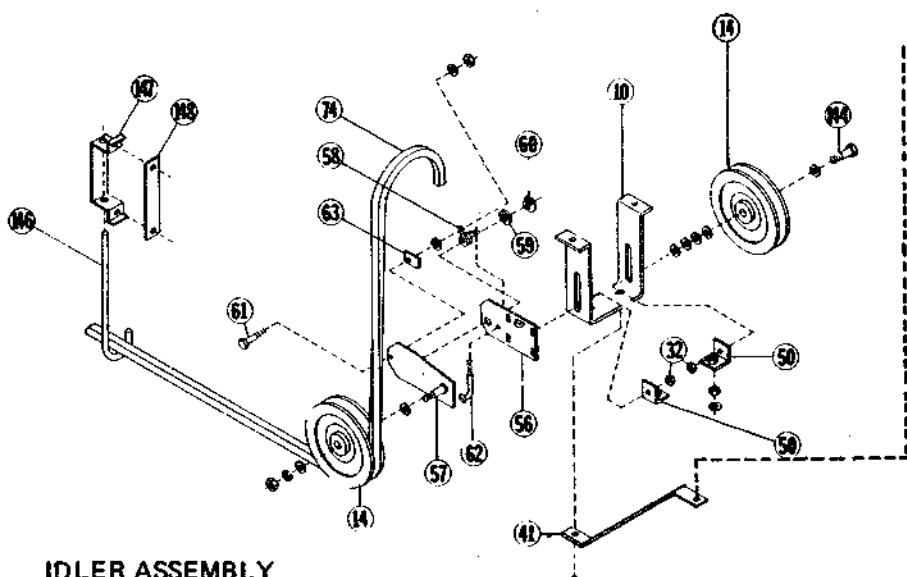
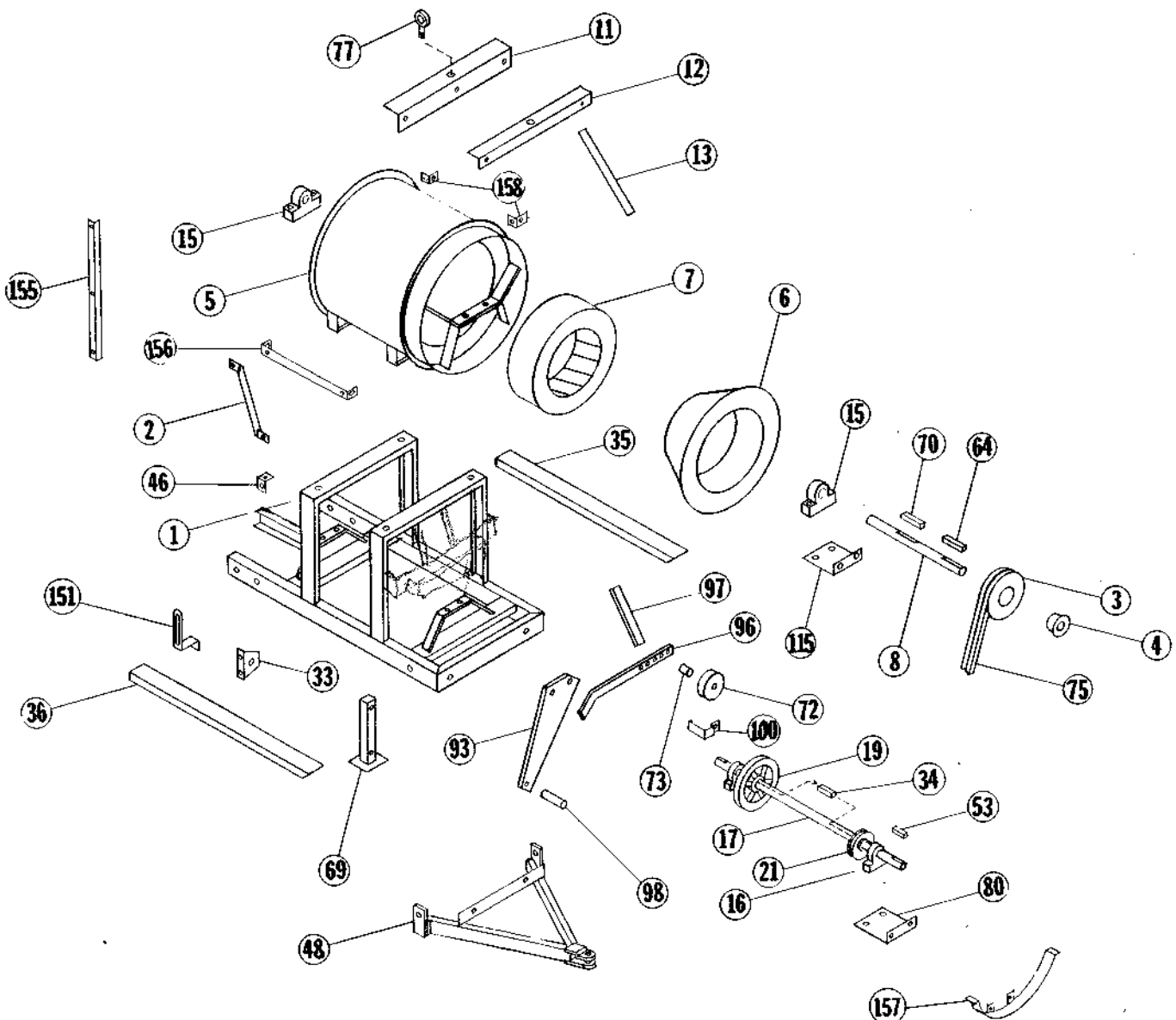

IDLER ASSEMBLY

POWER UNIT ASSEMBLY (QF)

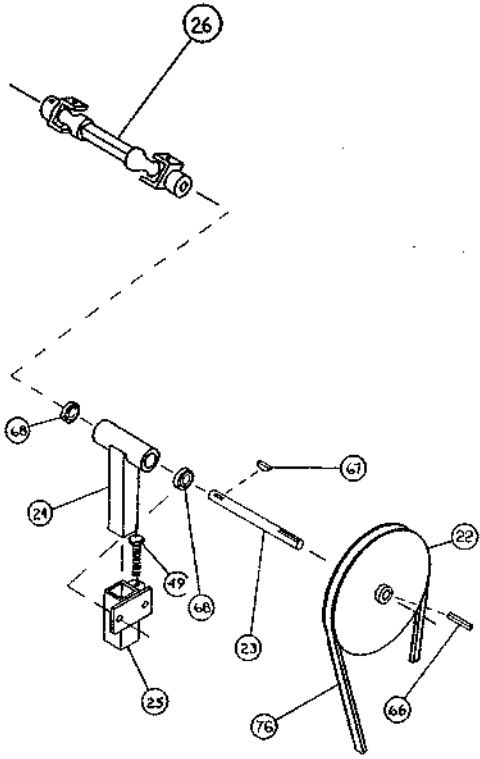

AGITATOR BELT TIGHTENER ASSEMBLY

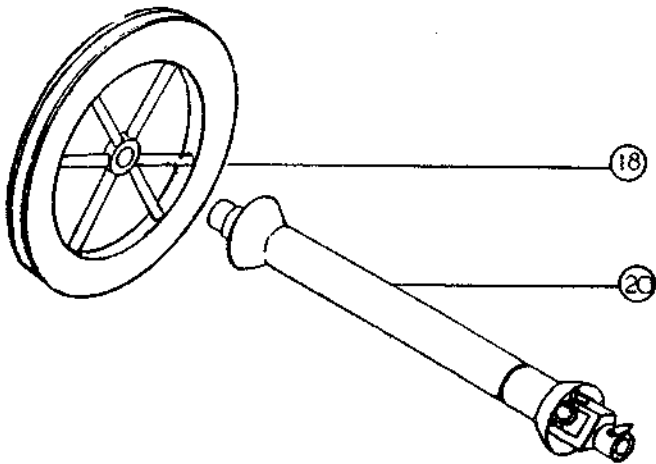
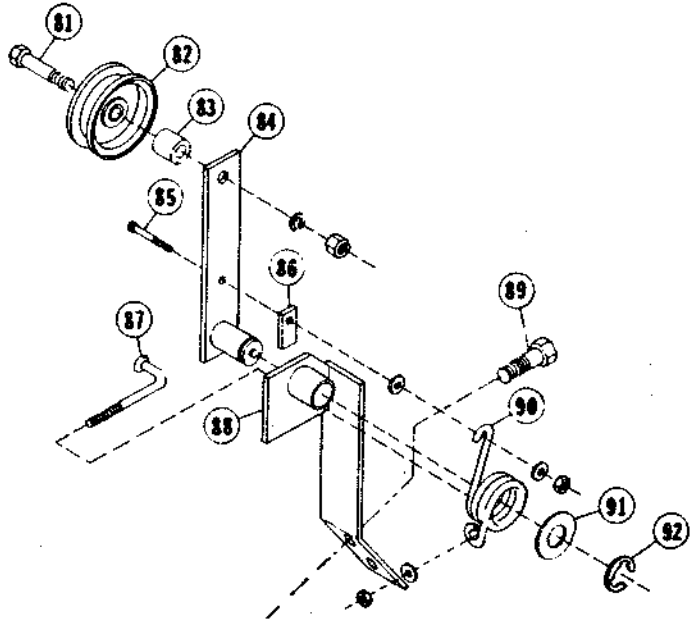

POWER UNIT ASSEMBLY (QF)

REF. NO.	PART NO.	NO. REQ'D.	DESCRIPTION
1	D52017	1	Frame Power
2	D52022	2	Brace
3	76056	1	Sheave, Fan Driven (2B 7.0) 76017 2B 6.8 L/Hals.
4	76002	1	Hub, Fan Driven Sheave
5	74156	1	Housing, In-Line Fan
6	D57300	1	Venturi, In-Line Fan
7	D52072	1	Fan
8	D52082	1	Shaft, Fan
10	D32010	1	Support, Idler
11	D57100	1	Support, Large Top Panel
12	D57105	1	Support, Small Top Panel
13	D57200	4	Brace, Top Panel
14	D22145	2	Sheave, Idler
15	85019	2	Bearing, 2" Pillow Block
16	D22097	2	Bearing, 1½" Pillow Block
17	D57115	1	Shaft, Power
18	D22170	1	Sheave, Fan Drive (2B 24)
19	D22180	1	Sheave, Auger Drive (1C9)
20	D52192	1	Tumbler, PTO Drive
21	D22780	1	Sheave, Agitator Drive (1B4)
22	D22790	1	Sheave, Agitator Driven (1B16)
23	D22850	1	Jackshaft, Agitator
24	D22861	1	Housing, Agitator Bearing w/o Bearings
24	D22866	1	Agitator Bearing Housing w/Bearings
25	D22871	1	Mount, Agitator Bearing Housing
26	D59342	1	Tumbler, Agitator Drive
27	D57345	1	Panel, Upper Rear Rt.
28	D57340	1	Panel, Lower Rear Rt.
29	D37261	1	Door, Rt. Upper
31	72591	4	Machine Bushing, 7/8"
32	72255	2	Nut, 5/8" Jam
33	D57225	4	Support, Wrapper
34	73411	2	Key, 3/8" sq. x 1½" lg.
35	D57120	1	Support, Lower Panel Left
36	D57110	1	Support, Lower Panel Right
37	73534	2	Pin, Cotter 1/8" x 1¼"
38	D57260	1	Door, Left
39	D57265	1	Filler, Door
40	D57261	1	Door, Right Lower
41	D57125	1	Brace, Idler Support
43	73332	4	Zerk, 1/8" NPT Female Grease
44	73150	4	Grease Line, 3/16" Copper x 5 ft. lg.
45	73109	8	Compression Fitting, 3/16" Tube to 1/8 N.P.T.
46	D57315	1	Brace, Junction Box
47	71113	1	Capscrew, ½" x 4½"
48	D52464	1	Hitch
49	71957	3	Capscrew, ½" x 5" Full Thread
50	D22260	2	Tightner
51	D57251	1	Panel, Right Lower Front
52	D57160	1	Panel, Left Lower Front
53	73415	1	Key 3/8" sq. x 4¼"
54	D22099	As Req'd.	Spacer
56	D22801	1	Fixed Member, Spring Loaded Idler
57	D22812	1	Pivot Member, Spring Loaded Idler
58	73308	1	Spring
59	D22820	1	Washer
60	73231	1	Ring, Retaining
61	71028	1	Capscrew, 5/16" x 1¼"
62	D22840	1	L-Bolt
63	D22830	1	Stop, Pivot
64	73424	1	Key, ½" x ½" x 3-7/8"
65	71110	3	Capscrew, ½" x 3"
66	73400	1	Key, ¼" sq. x 1¼"
67	42-18282	1	Key, 808 Woodruff
68	42-16334	2	Bearing, Agitator Jackshaft
69	D50570	2	Jacks
70	73419	1	Key, ½" x ½" x 2½"
72	42-16336	1	Pulley, Idler
73	D32220	1	Spacer
74	D52620	1	Belt, Auger Drive (C255)
75	D52272	1	Belt, Fan Drive (B148)

POWER UNIT ASSEMBLY (QF)

REF. NO.	PART NO.	NO. REQ'D.	DESCRIPTION
76	D57220	1	Belt, Agitator Drive (B70)
77	71941	2	Eyebolt, 1/2" x 1 1/2"
79	71051	1	Capscrew 3/8" x 3/4"
80	D57135	1	Belt Retainer, Lower Fan
	D52921	1	Agitator Idler Assembly (includes items 81-92 inclusive)
81	71109	1	Capscrew, 1/2" x 2 3/4"
82	42-16335	1	Pulley, Idler
83	D22927	1	Spacer, Idler
84	D22926	1	Arm, Idler
85	71029	1	Capscrew, 5/16" x 1 1/2"
86	D22830	1	Stop, Pivot
87	D22840	1	L-Bolt
88	D52926	1	Mount, Idler
89	71053	2	Capscrew, 3/8" x 1 1/4"
90	73308	1	Spring
91	D22820	1	Washer
92	73231	1	Ring, Retainer
93	D57130	1	Handle, Clutch
96	D57150	1	Link, Clutch Handle
97	D57145	1	Arm, Clutch Handle
98	D57155	1	Tube, Clutch Handle
100	D32260	1	Guide, for Belt
115	D57140	1	Brake, Fan Sheave
118	73048	2	Adapter, Grease Line, 1/4" x 28 Male to 1/8" N.P.T. Female x 90°
119	D57350	1	Panel, Right Fan Guard
120	D57180	1	Panel, Left Fan Guard
121	D57170	1	Panel, Top Fan Guard
122	D57186	1	Panel, Right Lower Rear
123	D57270	1	Panel, Left Lower Rear
124	D57175	1	Guard, Front Belt
125	D52892	1	Wrapper, Right Power Frame (Micro-Pro)
125	D52894	1	Wrapper, Right Power Frame
126	D52131	1	Wrapper, Left Power Frame
127	D52901	1	Wrapper, Front Power Frame
128	D57195	1	Grill
131	74620	1	Decal, Valve
133	73682	1	Decal, Caution Be a Safe Operator
134	73661	1	Decal, Danger LP Gas Supply
135	73668	1	Decal, Caution Fan Clutch
136	73607	1	Decal, Max. PTO speed 540 RPM
137	74706	1	Decal, Max. Fan speed 1700 RPM
138	73949	1	Decal, GT Logo
143	73833	1	Decal, Danger Keep Hands & Feet Away
144	71135	1	Capscrew, 5/8" x 3"
145	73981	1	Decal, DANGER - Electrocutation
146	D21420	1	Rod, Auger Belt Guide
147	D21430	1	Bracket, Auger Belt Guide Rod
148	D21440	1	Clamp, Auger Guide Bracket
149	73286	1	Grommet, Slotted Hole
150	D22146	1	Sheave, Idler
151	D57215	1	Lock, Clutch
152	74705	1	Decal, Grease Line
153	D57280	1	Panel, Rear
154	D57275	1	Frame, Right
155	D37075	2	Brace, Panel
156	D57285	1	Bracket, RH Fan Guard
157	D57325	1	Guide, for Belt
158	D37285	2	Bracket, LH Fan Guard

NOTE: For nuts, washers and lockwashers - see page 90.

POWER UNIT ASSEMBLY

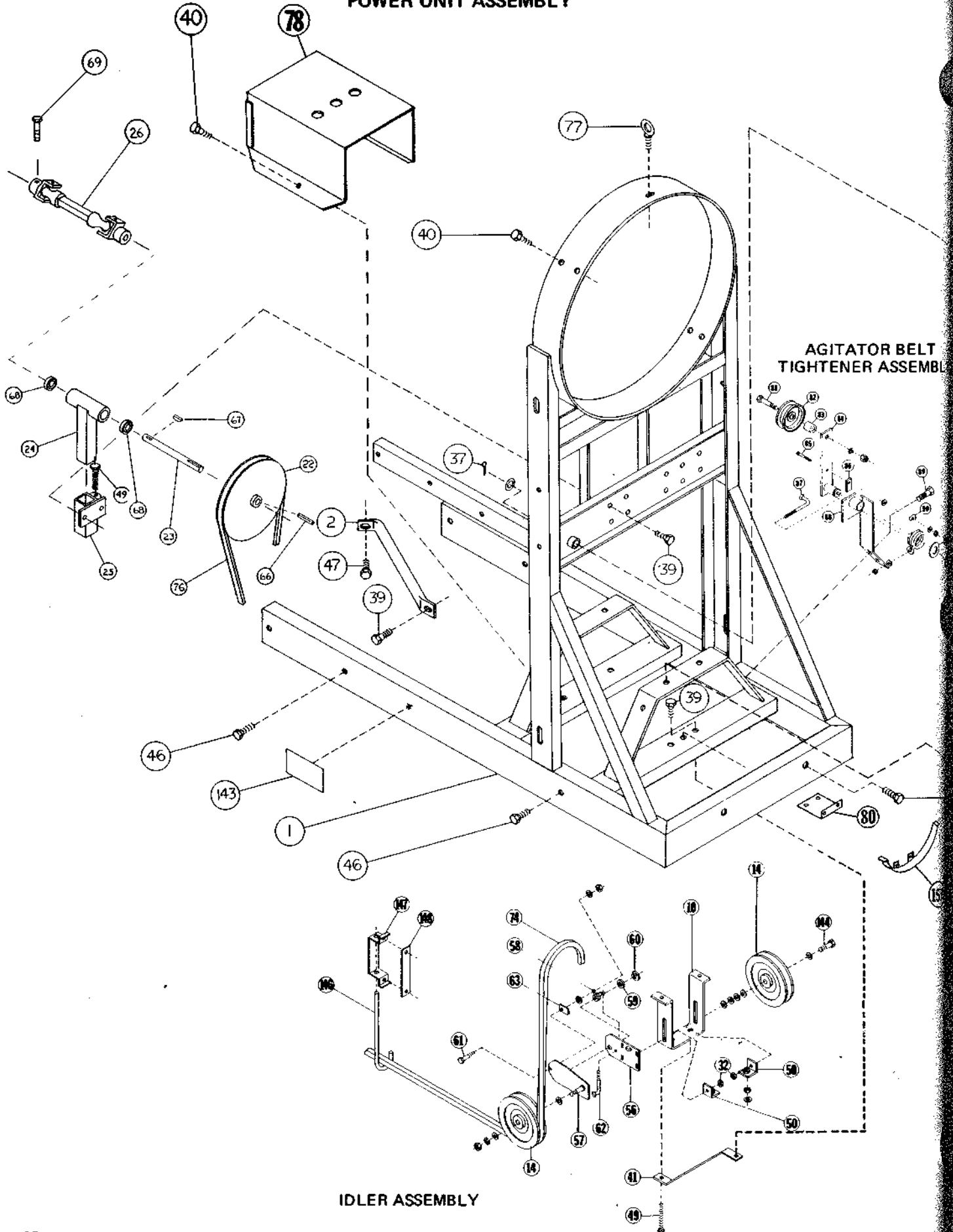

AGITATOR BELT TIGHTENER ASSEMBLY

IDLER ASSEMBLY

POWER UNIT ASSEMBLY

FAN CLUTCH ASSEMBLY

FAN ASSEMBLY

PTO ASSEMBLY

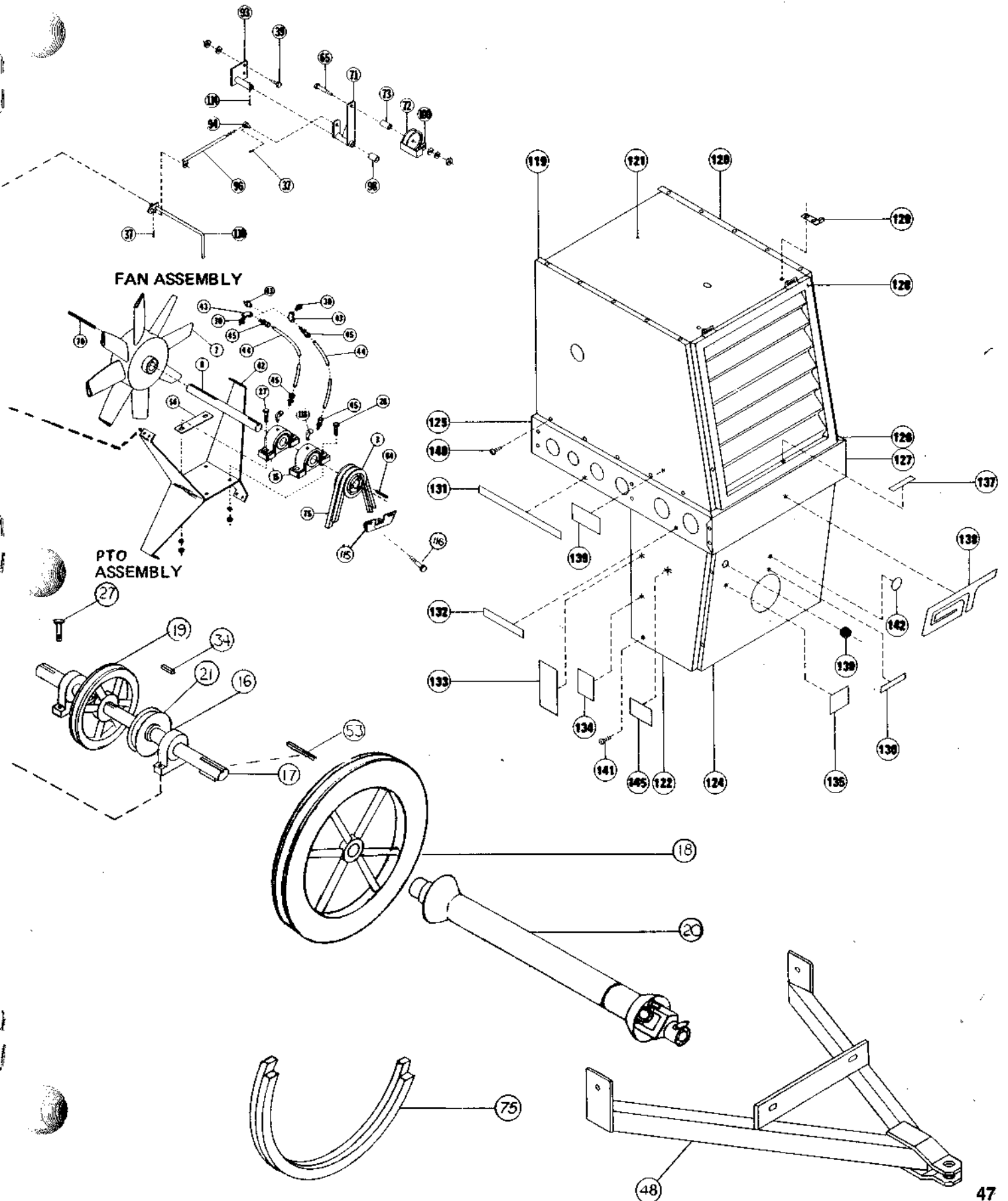

POWER UNIT ASSEMBLY

REF. NO.	PART NO.	NO. REQ'D.	DESCRIPTION
1	D52016	1	Frame Power
2	D52021	2	Brace
3	76006	1	Sheave, Fan Driven (2B 5.6)
	76007	1	Hub, Fan Driven Sheave
7	D52071	1	Fan
8	D52081	1	Shaft, Fan
10	D32010	1	Support, Idler
14	D22145	2	Sheave, Idler
15	D22090	2	Bearing, 1½" Pillow Block w/Shim & Adapter
16	D22097	2	Bearing, 1½" Pillow Block
17	D22161	1	Shaft, Power
18	D22170	1	Sheave, Fan Drive (2B 24)
19	D22180	1	Sheave, Auger Drive (1C9)
20	D52192	1	Tumbler, PTO Drive (See page 35 for parts)
21	D22780	1	Sheave, Agitator Drive (1B4)
22	D22790	1	Sheave, Agitator Driven (1B16)
23	D22850	1	Jackshaft, Agitator
24	D22861	1	Housing, Agitator Bearing w/o Bearings
24	D22866	1	Agitator Bearing Housing w/Bearings
25	D22871	1	Mount, Agitator Bearing Housing
26	D58250	1	Tumbler, Agitator Drive (See page 34 for parts)
27	71106	6	Capscrew, ½" x 2"
28	71107	2	Capscrew, ½" x 2¼"
29	71823	28	Machine Screw - ¼" - 20 x ½" Slotted Head
31	72591	4	Machine Bushing, 7/8"
32	72255	2	Nut, 5/8" Jam
34	73411	2	Key, 3/8" sq. x 1½" lg.
37	73534	2	Pin, Cotter 1/8" x 1½"
38	71129	3	Capscrew, 5/8" x 1½"
39	71102	11	Capscrew, ½" x 1"
40	71053	12	Capscrew, 3/8" x 1¼"
41	D52632	1	Brace, Idler Support
42	D52691	1	Brace, Fan Shaft Support
43	73332	2	Zerk, 1/8" NPT Female Grease
44	D52930	2	Grease Line, Fan Bearing
45	73109	4	Compression Fitting, 3/16" Tube to 1/8 N.P.T.
46	71111	8	Capscrew, ½" x 3½"
47	71113	1	Capscrew, ½" x 4½"
48	D52462	1	Hitch
49	71957	3	Capscrew, ½" x 5" Full Thread
50	D22260	2	Tightener
53	73415	1	Key 3/8" sq. x 4¼"
54	D22099	As Req'd.	Spacer
56	D22801	1	Fixed Member, Spring Loaded Idler
57	D22812	1	Pivot Member, Spring Loaded Idler
58	73308	1	Spring
59	D22820	1	Washer
60	73231	1	Ring, Retaining
61	71028	1	Capscrew, 5/16" x 1¼"
62	D22840	1	L-Bolt
63	D22830	1	Stop, Pivot
64	73411	1	Key, 3/8" x 3/8" x 1½"
65	71110	3	Capscrew, ½" x 3"
66	73400	1	Key, ¼" sq. x 1¼"
67	42-18282	1	Key, 808 Woodruff
68	42-16334	2	Bearing, Agitator Jackshaft
69	73508	1	Capscrew, 3/8" x 2½" H.T.
70	73420	1	Key, 3/8" sq. x 6-3/8"
71	D52161	1	Arm, Fan Clutch Idler
72	42-16336	1	Pulley, Idler
73	D32220	1	Spacer
74	D52620	1	Belt, Auger Drive (C255)
75	D52272	1	Belt, Fan Drive (B148) (Set of 2)

POWER UNIT ASSEMBLY

REF. NO.	PART NO.	NO. REQ'D.	DESCRIPTION
76	42-16125	1	Belt, Agitator Drive (B85)
77	71941	1	Eyebolt, 1/2" x 1 1/2"
78	D22652	1	Guard, Power Shaft
	D52921		Agitator Idler Assembly (includes items 81-92 inclusive)
79	71051	1	Capscrew, 3/8" x 3/4"
80	D57135	1	Belt Retainer, Lower Fan
81	71109	1	Capscrew, 1/2" x 2 3/4"
82	42-16335	1	Pulley, Idler
83	D22927	1	Spacer, Idler
84	D22926	1	Arm, Idler
85	71029	1	Capscrew, 5/16" x 1 1/2"
86	D22830	1	Stop, Pivot
87	D22840	1	L-Bolt
88	D52926	1	Mount, Idler
89	71053	2	Capscrew, 3/8" x 1 1/4"
90	73308	1	Spring
91	D22820	1	Washer
92	73231	1	Ring, Retainer
93	D52171	1	Pivot Clutch Idler
94	D32270	1	Pin, Fan Clutch Swivel
96	D52235	1	Arm, Link
98	D32040	1	Tube, Belt Retaining
100	D32260	1	Guide, Fan Clutch Belt
110	D52152	1	Handle, Fan Clutch
114	73536	1	Pin, Cotter 1/8" x 1 3/4"
115	D32250	1	Brake, Fan Sheave
116	71061	2	Capscrew, 3/8" x 3 1/2"
117	72364	1	Nut, 3/8" Spot Weld
118	73048		Adapter, Grease Line, 1/4" x 28 Male to 1/8" N.P.T. Female x 90°
119	D52663	1	Panel, Right Fan Guard
120	D52671	1	Panel, Left Fan Guard
121	D52042	1	Panel, Top Fan Guard
122	D52885	1	Panel, Right Belt Guard
123	D52880	1	Panel, Left Belt Guard
124	D52062	1	Guard, Front Belt
125	D52893	1	Wrapper, Right Power Frame - (LP Gas)
126	D52130	1	Wrapper, Left Power Frame
127	D52900	1	Wrapper, Front Power Frame
128	D52052	1	Grill
129	D32120	2	Grill Hinge Strap
130	73278	1	Grommet
131	73957	1	Decal, Valve
132	73958	1	Decal, Plenum & Grain Temperature
133	73682	1	Decal, Caution Be a Safe Operator
134	73661	1	Decal, Danger LP Gas Supply
135	73668	1	Decal, Caution Fan Clutch
136	73607	1	Decal, Max. PTO Speed 540 RPM
137	73619	1	Decal, Max. Fan Speed 2250 RPM
138	73949	1	Decal, GT Logo
140	71823	42	1/4" x 20 x 1/2" Slotted HD Machine Screw
141	71825	6	1/4" x 20 x 3/4" Slotted HD Machine Screw
143	73833	1	Decal, Danger: Keep Hands & Feet Away
144	71135	1	Capscrew, 5/8" x 3"
145	73981	1	Decal, DANGER - Electrocution
146	D21420	1	Rod, Auger Belt Guide
147	D21430	1	Bracket, Auger Belt Guide Rod
148	D21440	1	Clamp, Auger Guide Bracket
157	D57325	1	Guide, Fan Belt

NOTE: For nuts, washers and lockwashers - see page 90.

PTO SENSOR ASSEMBLY

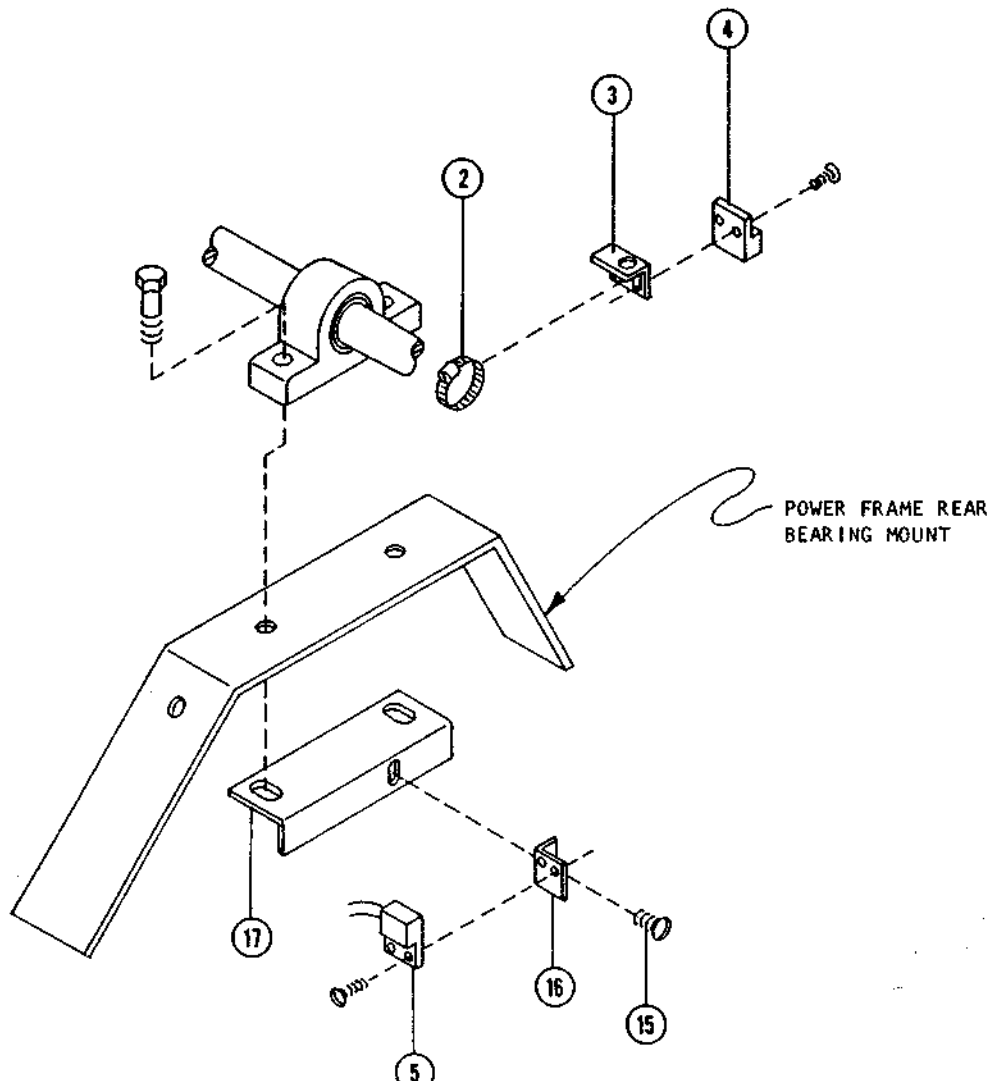

REF. NO.	PART NO.	NO. REQ'D.	DESCRIPTION
2	79065	1	Clamp, Sensor
3	D25900	1	Angle, Sensor
4	77247	1	Magnet
5	77248	1	Sensor, Pickup
15	71823	1	Screw, 1/4 x 1/2 Machine
16	D25795	1	Mount, PTO Sensor
17	D25830	1	Bracket, PTO

MICRO-PRO VERTICAL AUGER SENSOR ASSEMBLY

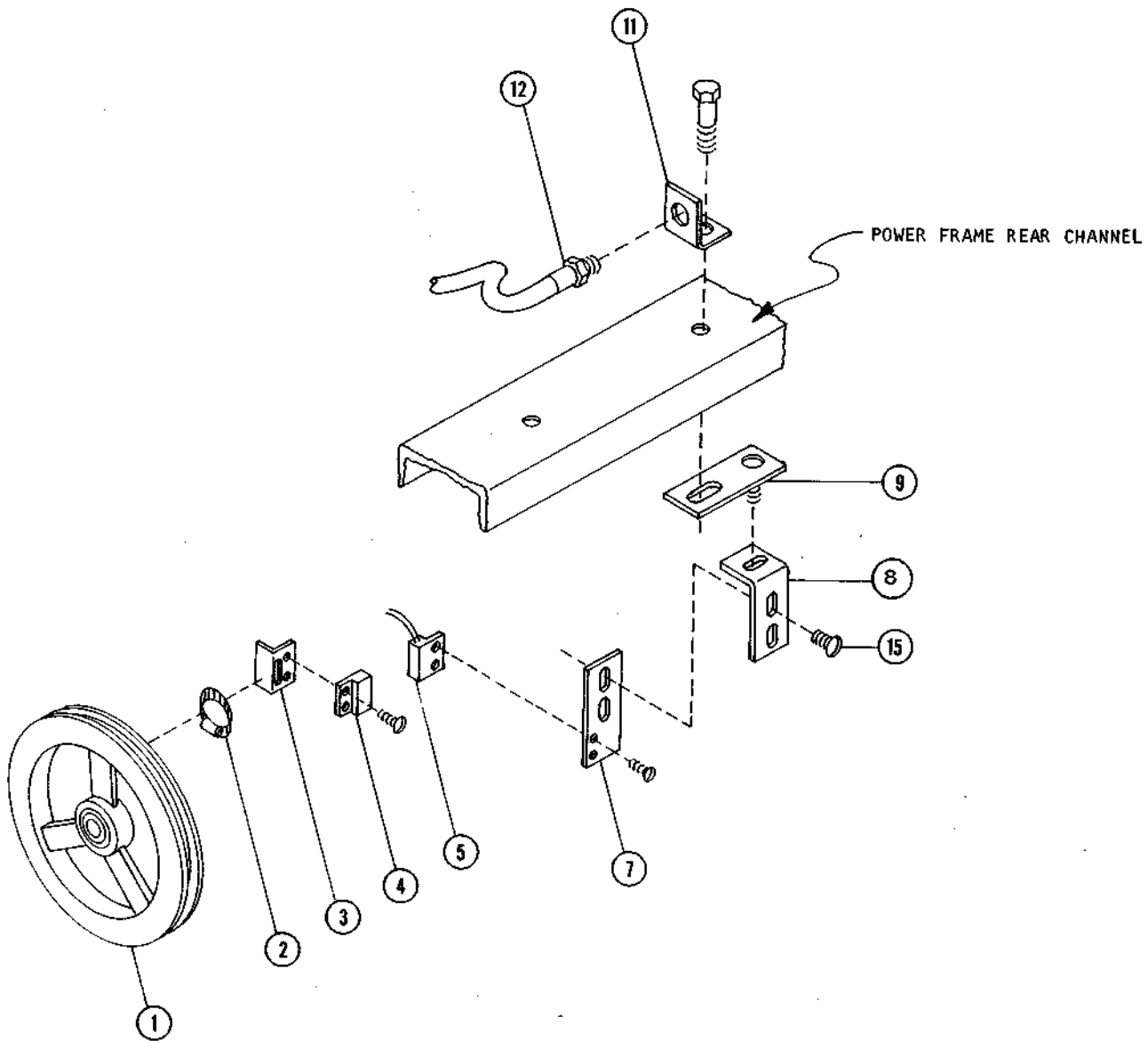

REF. NO.	PART NO.	NO. REQ'D.	DESCRIPTION
1	D22145	1	Sheave, Idler
	85021	2	Bearing only
2	79065	1	Clamp
3	D25900	1	Angle, Vertical Auger Sensor
4	77247	1	Magnet
5	77248	1	Sensor, Pickup
7	D25805	1	Bracket, Sensor Mtg.
8	D25825	1	Bracket, Upper
9	D25850	1	Tab, Sensor
11	D25820	1	Mount, Conduit
12	73157	1	Connector, 3/8 St
15	71823	3	Screw, 1/4 x 1/2 Machine

AGITATOR DRIVE TUMBLER (QF)
D59342

REF. NO.	PART NO.	NO. REQ'D.	DESCRIPTION
1	42-16181	2	U-Joint Kit
2	42-16182	2	Yoke w/Keyway

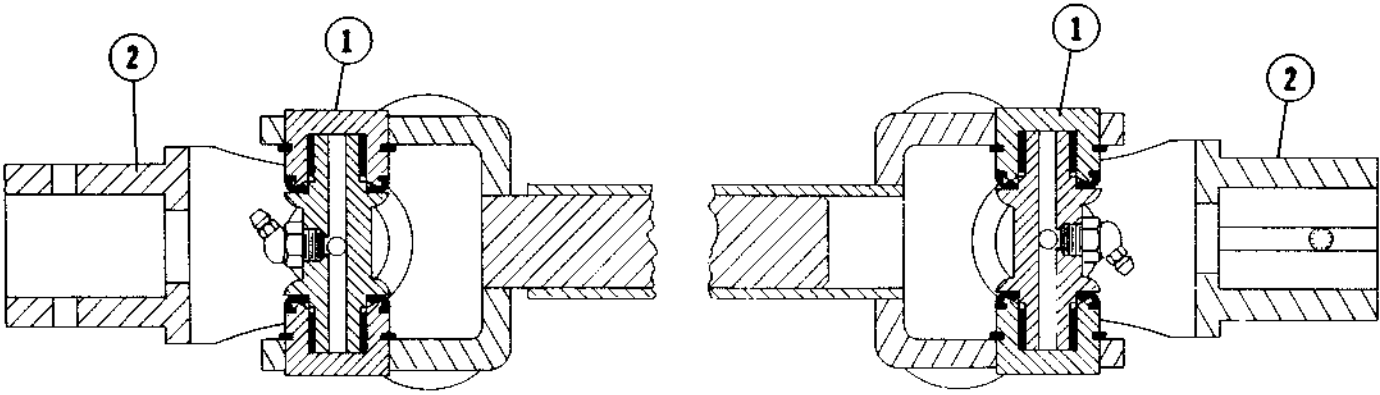

LOADING AUGER TUMBLER
D59343

REF. NO.	PART NO.	NO. REQ'D.	DESCRIPTION
1	42-16181	2	U-Joint Kit
2	42-16182	2	Yoke w/Keyway

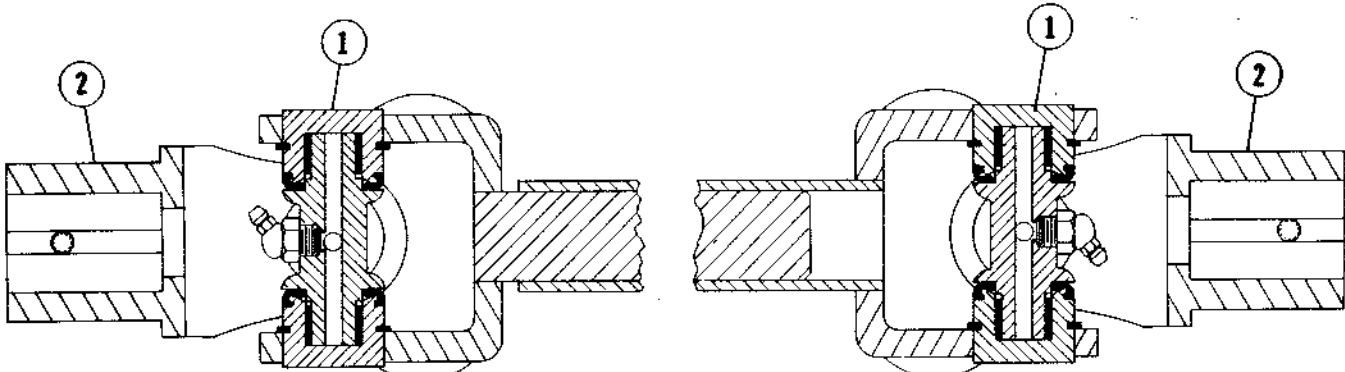

NOTE: For nuts, washers and lockwashers - see page 90.

**PTO TUMBLER SHAFT
D52192
REX TUMBLER**

REF. NO.	PART NO.	NO. REQ'D.	DESCRIPTION
1	73549	1	Yoke w/Spline
2	73550	1	Yoke w/Keyway
3	73548	2	U-Joint Kit
4	73573	2	Nylon Bearing Kit
5	75500	1	Safety Shield, Outer
6	75501	1	Safety Shield, Inner

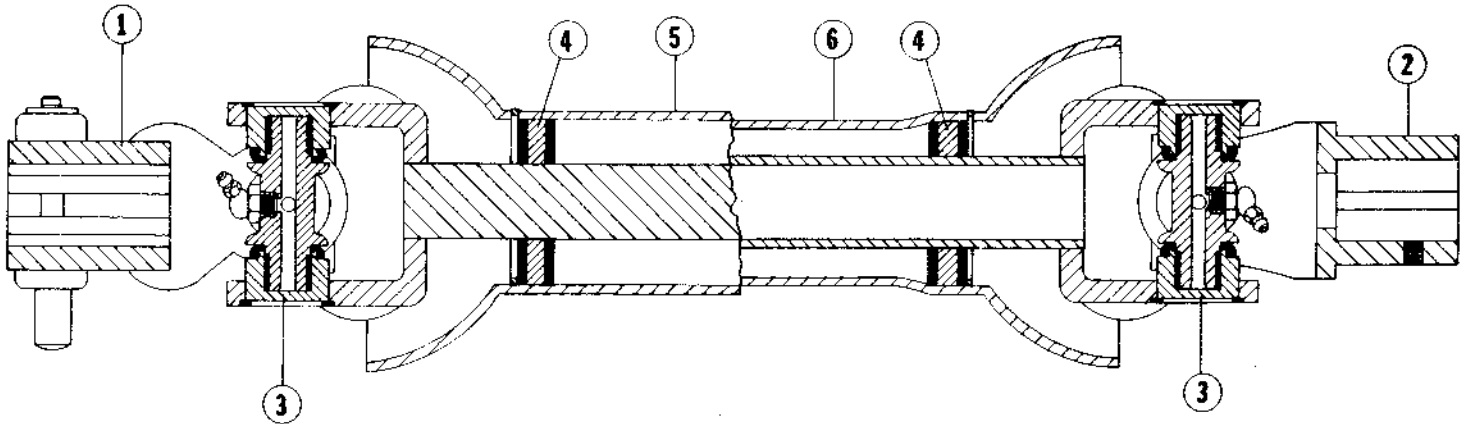

**AGITATOR DRIVE TUMBLER
D28250
5**

REF. NO.	PART NO.	NO. REQ'D	DESCRIPTION
1	42-16181	2	U-Joint Kit
2	42-16182	1	Yoke w/Keyway
3	73596	1	Yoke w/Pin Hole

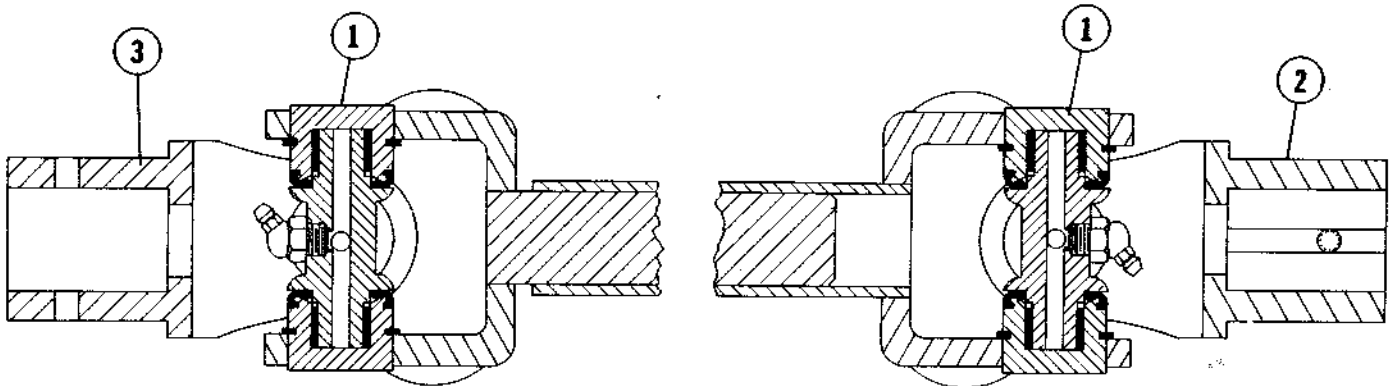

NOTE: For nuts, washers and lockwashers - see page 90.

BURNER ASSEMBLY (QF)

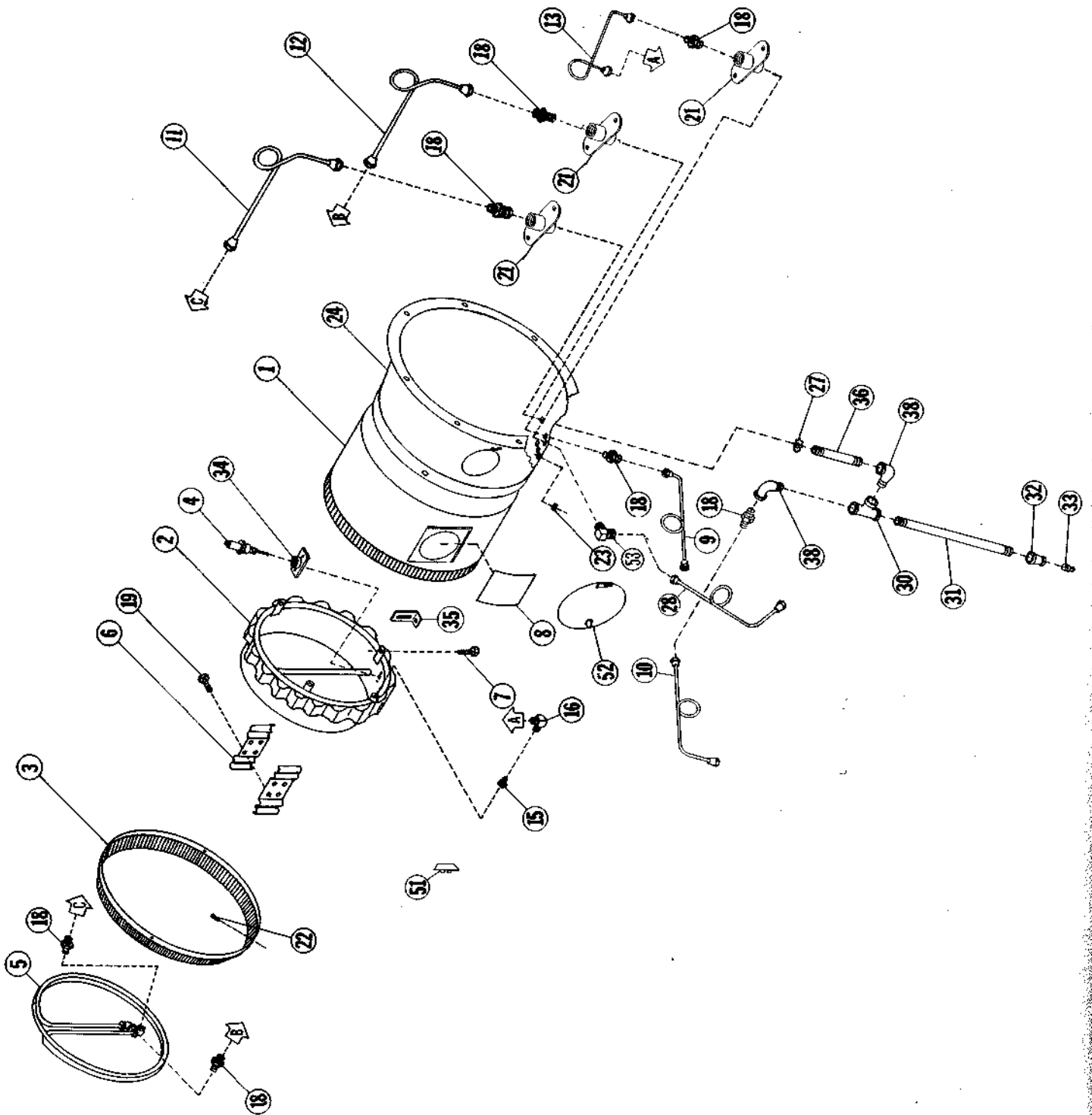

BURNER ASSEMBLY (QF)

REF. NO.	PART NO.	NO. REQ'D	DESCRIPTION
1	D57210	1	Tube, Burner (Propane)
2	D52303	1	Burner, Ring (Propane)
3	D52520*	1	Ring, Flame Deflector
4	D22320	1	Spark Plug
5	57001279*	1	Vaporizer, Ring
6	57001242	2	Bracket, Vaporizer
7	71959	3	Bolt, Burner Mt.
8	D22462	1	Window, Plexiglass
9	D57245	1	Tube, Outside Liquid to Vapor
10	D57235	1	Tube, Outside Vapor to Plumb.
11	57001268*	1	Tube, Inside Vapor
12	57001267*	1	Tube, Inside Liquid
13	D52374*	1	Tube, Inside Vapor to Burner
15	57001247	1	Orifice - LP
16	D32300*	1	Holder, Orifice
18	73086*	7	Adapter, 1/2" P. to 1/2" T. Union
19	71028*	4	Capscrew, 5/16" x 1 1/8" Hex
21	D37330	3	Coupler, Union Brkt.
22	71942*	4	Screw, No. 14 x 3/4" Metal
23	73270	2	Grommet, 3/8" I.D. Rubber
24	74155	1	Adaptor, Fan
25	72035	2	Screw, No. 8 x 1/2" Metal
27	77100*	1	Nut, Conduit
28	D37231	1	Tube, Outside, Vapor to Burner
30	72947	1	Tee, 1/2" x 1/2" x 1/2" N.P.T.
31	72928*	1	Nipple, 1/2" x 13"
32	72949	1	Reducer, 1/2" x 1/4"
33	72633*	1	Plug, 1/4" N.P.T. Plug
34	57001241	1	Mount, Spark Plug
35	D32130	1	Bracket, Flame Detector Bulb Mount
36	72797*	1	Nipple, 1/2" x 4 1/2" XH
38	72946	2	Elbow, 1/2" x 90° St.
51	D32370	1	Shield, Burner (Propane)
52	D37206	1	Cover, Hole
53	73101	1	Adapter, 90°

NOTE: *Propane Burners Only

BURNER ASSEMBLY

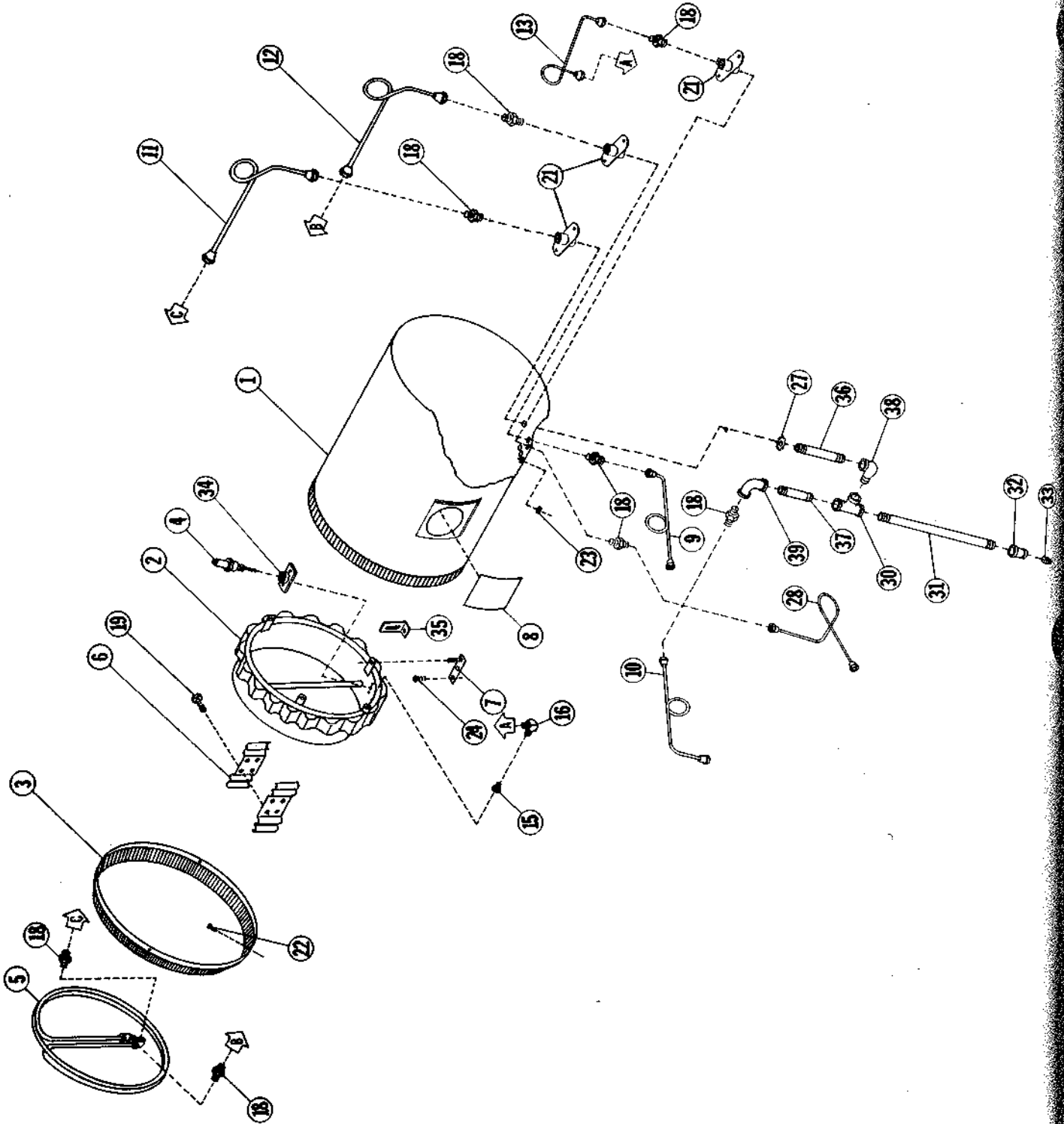

BURNER ASSEMBLY

REF. NO.	PART NO.	NO. REQ'D.	DESCRIPTION
1	D52295	1	Tube, Burner (Propane)
1	D52960	1	Tube, Burner (Natural Gas)
2	D52303	1	Burner, Ring (Propane)
2	D52305	1	Burner, Ring (Natural Gas)
3	D52520*	1	Ring, Flame Deflector
4	D22320	1	Spark Plug
5	57001279*	1	Vaporizer, Ring
6	57001242*	2	Bracket, Vaporizer
7	57001240	3	Mount, Burner
8	D22462	1	Window, Plexiglass
9	D32331*	1	Tube, Outside Liquid to Vapor
9	D52110	1	Tube, Outside Liquid to Vapor (CSA)
10	D32312*	1	Tube, Outside Vapor to Plumb.
11	57001268*	1	Tube, Inside Vapor
12	57001267*	1	Tube, Inside Liquid
13	D52374*	1	Tube, Inside Vapor to Burner
15	57001247	1	Orifice - LP
16	D32300*	1	Holder, Orifice
18	73086*	8	Adapter, $\frac{1}{2}$ " P. to $\frac{1}{2}$ " T. Union
19	71028*	4	Capscrew, $\frac{5}{16}$ " x $1\frac{1}{4}$ " Hex
21	D37330	3	Coupler, Union Brkt.
22	71942*	4	Screw, No. 14 x $\frac{3}{4}$ " Metal
23	73270	2	Grommet, $\frac{3}{8}$ " I.D. Rubber
24	71825	8	Machine Screw, $\frac{1}{4}$ " - 20 x $\frac{3}{4}$ " SL HD
25	72035	2	Screw, No. 8 x $\frac{1}{4}$ " Metal
27	77100*	1	Nut, Conduit
28	D52121*	1	Tube, Outside, Vapor to Burner
29	72790*	1	Nipple, $\frac{1}{2}$ " Close
30	72886*	1	Tee, $\frac{1}{2}$ " x $\frac{1}{2}$ " x $\frac{1}{2}$ " N.P.T.
31	72928*	1	Nipple, $\frac{1}{2}$ " x 13"
32	72910*	1	Reducer, $\frac{1}{2}$ " x $\frac{1}{2}$ "
33	72633*	1	Plug, $\frac{1}{2}$ " N.P.T. Pipe
34	57001241	1	Mount, Spark Plug
35	D32130	1	Bracket, Flame Detector Bulb Mount
36	72797*	1	Nipple, $\frac{1}{2}$ " x $4\frac{1}{2}$ " XH
37	72793*	1	Nipple, $\frac{1}{2}$ " x $2\frac{1}{2}$ " XH
38	72858*	1	Elbow, $\frac{1}{2}$ " x 90° St.
39	72843*	1	Elbow, $\frac{1}{2}$ " x 90°

NOTE: *Propane Burners Only

NOTE: For nuts, washers and lockwashers - see page 90.

PROPANE CONTROL CABINET ASSEMBLY MICRO-PRO

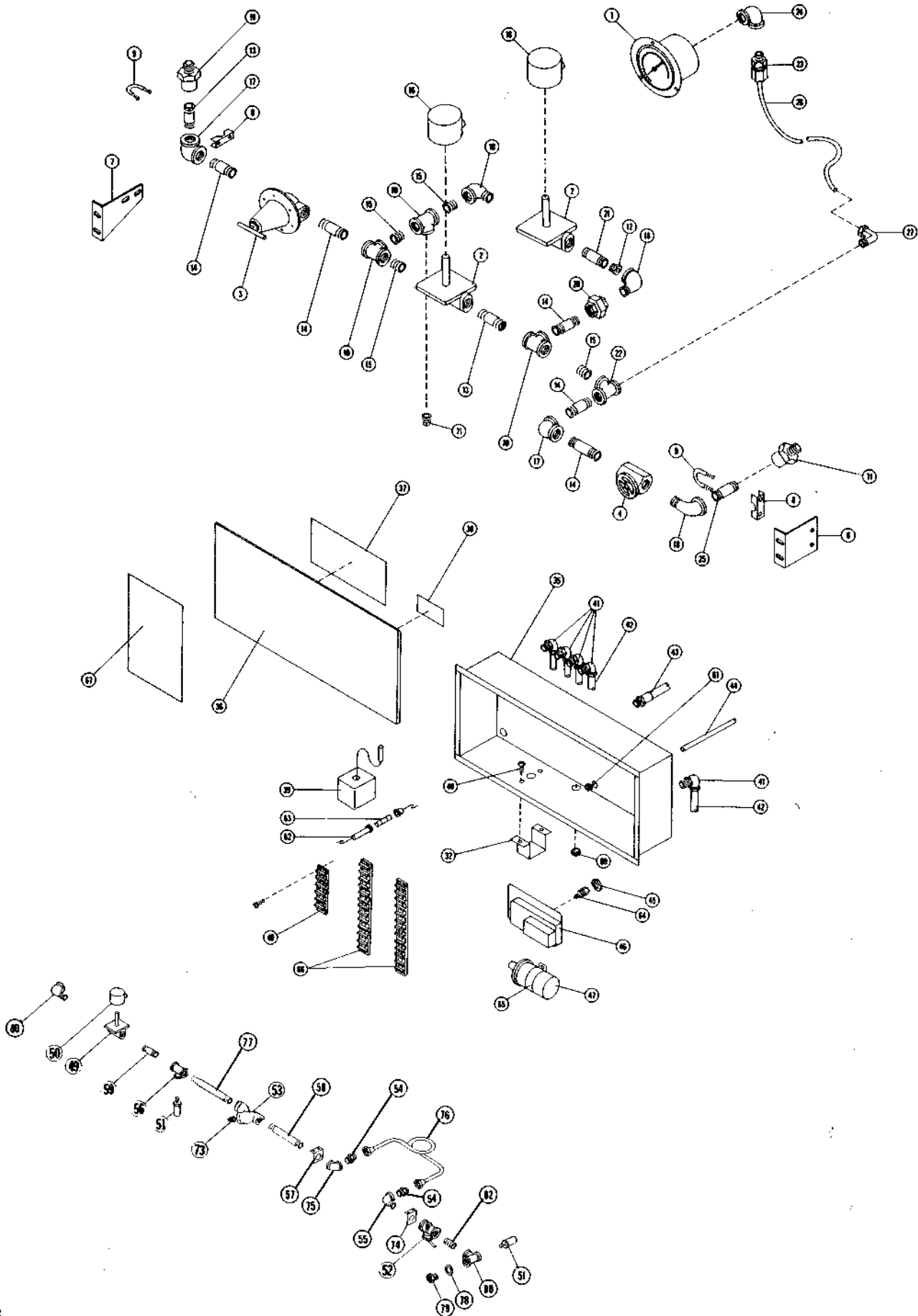

**PROPANE CONTROL CABINET ASSEMBLY
MICRO-PRO**

REF. NO.	PART NO.	NO. REQ'D	DESCRIPTION
1	D25102	1	Gauge, Pressure
2	77193	2	Valve, 1/2" Solenoid
3	D25191	1	Regulator, 1/2" Pressure
4	57001285	1	Valve, Ball
6	D25620	1	Bracket, Front Plumbing
7	D25631	1	Bracket, Rear Plumbing
8	D25610	2	Clamp, 1/2" Saddle
9	71987	2	U-Bolt
10	72886	3	Tee, 1/2"
11	73071	2	Connector, 1/2" T to 1/2" Pipe
12	D22415	1	Orifice
13	72792	2 3	Nipple, 1/2" x 2"
14	72791	5 4	Nipple, 1/2" x 1.5"
15	72790	4	Nipple, 1/2" Close
16	D25542	2	Coil, Solenoid
17	72945	2	Elbow, 1/2"
18	72858	3	Elbow, 1/2" Street
19	72673	1	Plug, 1/2" Pipe
20	72978	1	Union, 1/2"
21	D25865	1	Nipple, Orifice
22	72886	1	Tee, 1/2" x 1/2" x 1/2"
23	73110	1	Connector, 1/4" T to 1/4" Pipe
24	72841	1	Elbow, 1/2" x 90 Degree
25	72793	1	Nipple, 1/2" x 2.5"
26	D55310	1	Line, Pressure Gauge
27	73128	1	Elbow, 90 Degree Brass, 1/4" to 1/2" N.P.T.
32	D25251	1	Bracket, Plumbing
35	D25862	1	Box, Junction
36	D25512	1	Door, Junction Box
37	74618	1	Decal, Wiring Diagram
38	74619	1	Decal, Sequence
39	D25161	1	Detector, Flame
40	77231	1	Block, Terminal
41	73159	5	Connector, 3/8" x 90 Degree
42	73166	Per ft.	Conduit, 3/8" Liquidtite
43	73157	1	Connector, 3/8" Straight
44	D32020	1	Tube, Air Switch
45	72279	1	Nut, 1" NF Hex
46	K25030	1	Air Switch
47	77228	1	Coil
48	71683	2	Screw, 10 - 24 x 1/2" Machine
49	77192	1	Body, 3/8" N.P.T. Solenoid Valve
50	D25522	1	Coil, Solenoid Valve 12 Volt
51	D25240	2	Valve, 1/2" N.P.T. Relief
52	D25120	1	Valve, 3/8" N.P.T. Quick Acting
53	D25280	1	Strainer, 3/8" N.P.T.
54	73085	2	Connector, 1/2" Tube to 3/8" M.N.P.T.
55	72944	1	Elbow, 3/8" N.P.T. Street
56	72956	1	Tee, 3/8" N.P.T.
57	D25271	1	Bracket, Plumbing
58	72784	1	Nipple, 3/8" N.P.T. x 3" X.H.
59	72781	1	Nipple, 3/8" N.P.T. x 1.5" X.H.

**PROPANE CONTROL CABINET ASSEMBLY
MICRO-PRO**

REF. NO.	PART NO.	NO. REQ'D.	DESCRIPTION
60	73278	2	Grommet
61	73270	2	Grommet
62	77188	1	Holder, In-Line Fuse
63	77268	1	Fuse, 7 Amp
64	73110	1	Fitting, 1/2 T to 1/2 Pipe
65	77229	1	Bracket, Coil
66	77267	2	Block, Terminal
67	74658	1	Decal, Starting Instructions
	D22200	1	Wire, Tractor Lead-in
71	72673	1	Plug, 1/2" N.P.T. Pipe
73	72653	1	Plug, 3/8" N.P.T. Pipe
74	D25275	1	Bracket
75	72948	1	Elbow, 3/8" N.P.T.
76	D57242	1	Tube, Liquid Copper
77	72787	1	Nipple, 3/8 N.P.T. x 4 1/2"
78	72595	1	Washer
79	90037	1	Connector, 1/2" Hose to 3/8 N.P.T.
80	72956	1	Tee, 3/8
	72890	2	Bushing, 3/8" x 1/4" Reducer
82	72780	1	Nipple, 3/8" Close
	77245	Per Ft	Wire, Spark Plug
	73268	1	Terminal, Spark Plug
	77249	1	Terminal, Straight
	77250	1	Boot
83	73100	1	Elbow, 1/2 T - 3/8 N.P.T.

SOLENOID VALVE ASSEMBLY

REF. NO.	PART NO.	DESCRIPTION
60	73507	Kit, 3/8" Solenoid Valve Diaphragm Repair
60	73508	Kit, 1/2" Solenoid Valve Diaphragm Repair
60	77506	Kit, 1" Solenoid Valve Diaphragm Repair (Natural Gas)
62	D25542	Coil, 12 Volt Solenoid Valve, 27" Leads w/Forks

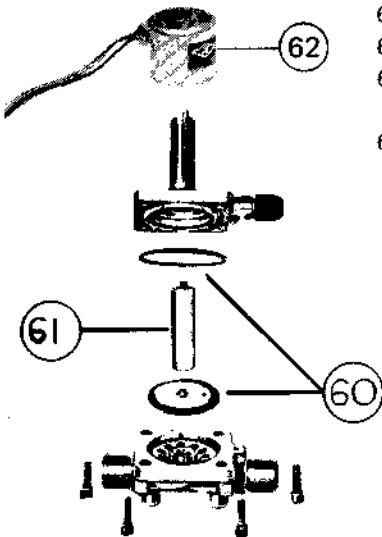

PROPANE CONTROL CABINET ASSEMBLY QUIET FAN - NON MICRO

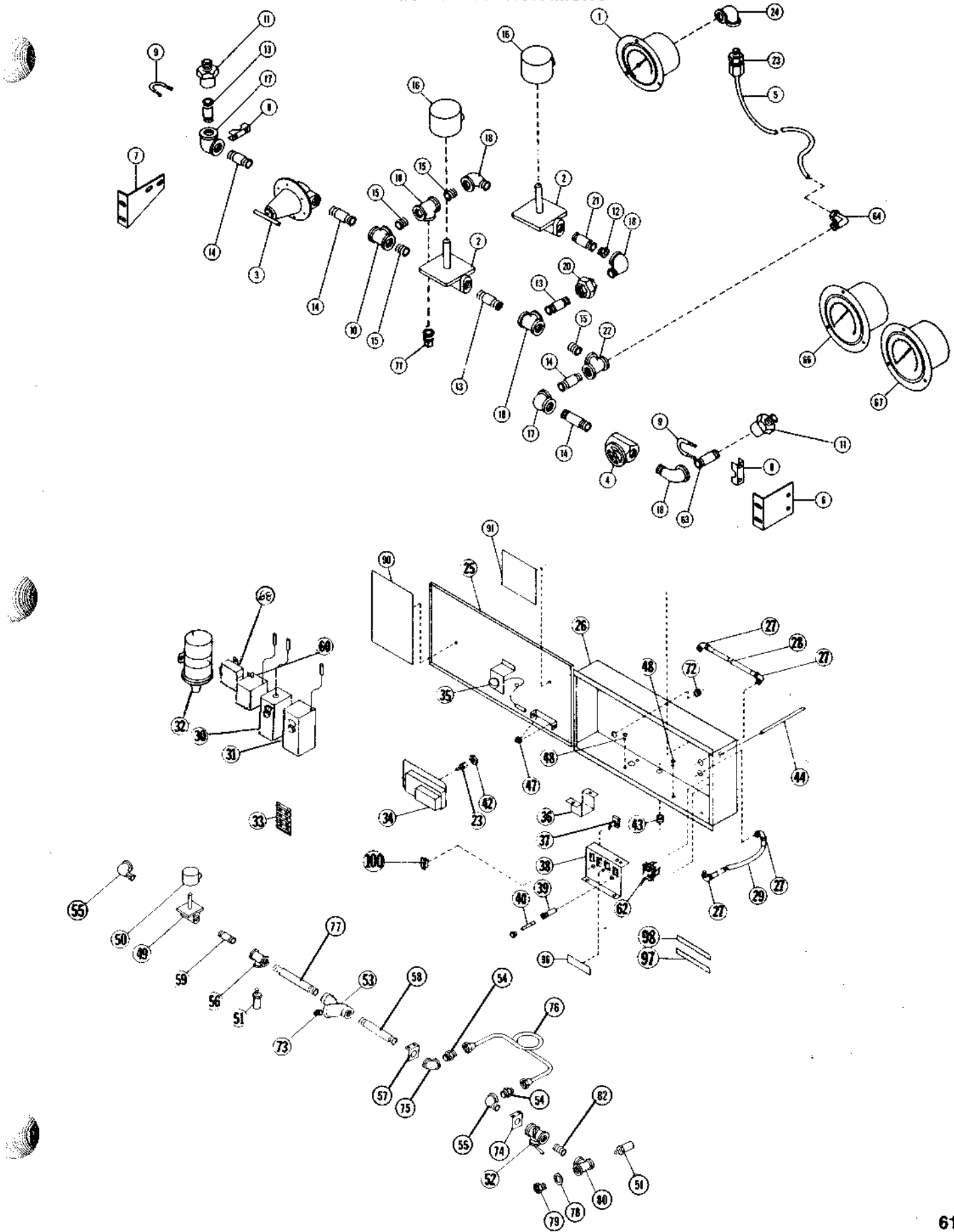

**PROPANE CONTROL - CABINET ASSEMBLY
QUIET FAN - NON MICRO**

REF. NO.	PART NO.	NO. REQ'D	DESCRIPTION
1	D25102	1	Gauge, Pressure
2	77193	2	Valve, 1/2" Solenoid
3	D25191	1	Regulator, 1/2" Pressure
4	57001285	1	Valve, Ball
5	D55310	1	Line, Pressure Guage
6	D25620	1	Bracket, Front Plumbing
7	D25631	1	Bracket, Rear Plumbing
8	D25610	2	Clamp, 1/2" Saddle
9	71987	2	U-Bolt
10	72886	3	Tee, 1/2"
11	73071	2	Connector, 1/2" T to 1/2" Pipe
12	D22415	1	Orifice
13	72792	3	Nipple, 1/2" x 2"
14	72791	4	Nipple, 1/2" x 1.5"
15	72790	4	Nipple, 1/2" close
16	D25542	2	Coil, Solenoid
17	72945	2	Elbow, 1/2"
18	72858	3	Elbow, 1/2" Street
19	72673	1	Plug, 1/2" Pipe
20	72978	1	Union, 1/2"
21	D25865	1	Nipple, Orifice
22	72886	1	Tee, 1/2" x 1/2" x 1/2"
23	73110	1	Connctor, 1/4" T to 1/4" Pipe
24	72841	1	Elbow, 1/4" x 90 Degree
25	D25511	1	Door, Cabinet
26	D25503 D25843	1	Cabinet
27	73159	2	Connector, 3/8 Conduit x 90°
28	D25261 D 55260	1	Conduit 16" Lg
29	D25263 D 55260	1	Conduit, 12" Lg
30	D25770	1	Switch, Plenum
31	K25231	1	Thermostat, Grain Temperature
32	77228	1	Coil, Ignition, 12 Volt
33	77230	1	Block, Terminal
34	K25030	1	Switch, Air
35	73223	1	Light, Utility 12 Volt Only
36	D25251	1	Bracket, Solenoid
37	D25130	1	Switch, On-Off
38	D25212	1	Bracket, Switch
39	D25170	1	Holder, Fuse
40	77143	1	Fuse, 10 Amp
41	72093	2	Screw, No. 8 x 1" Metal
42	72279	1	Nut, 1" N.F. Hex Ham
43	73278	1	Grommet, 5/8 I.D. Rubber
44	D52321	1	Tube, Air Switch
	D22200	1	Wire, Tractor Lead-In

**PROPANE CONTROL CABINET ASSEMBLY
QUIET FAN - NON MICRO**

REF. NO.	PART NO.	NO. REQ'D.	DESCRIPTION
47	73271	2	Grommet, 1/4" I.D. Rubber
48	71683	5	Screw, 10 - 24 x 1/2" Slotted Head Machine
49	77192	1	Body, 3/8" N.P.T. Solenoid Valve (2) FOR CSA
50	D25522	1	Coil, Solenoid valve 12 Volt
51	D25240	2	Valve, 1/4" N.P.T. Relief
52	D25120	1	Valve, 3/8" N.P.T. Quick Acting
53	D25280	1	Strainer, 3/8" N.P.T.
54	73085	1	Connector, 1/2" Tube to 3/8" M.N.P.T. (CSA)
55	72857	1	Elbow, 3/8" N.P.T. Street (3) FOR CSA
56	72956	1	Tee, 3/8" N.P.T.
57	D25271	1	Bracket, Plumbing
58	72784	1	Nipple, 3/8" N.P.T. x 3" X.H. CSA
59	72781	4	Nipple, 3/8" N.P.T. x 1 1/2" X.H.
60	D25161	1	Flame Detector
62	D25140	1	Switch, Push to Start
63	72793	1	Nipple, 1/2" x 2.5"
64	73128	1	Elbow, 1/4" to 1/2" NPT Brass
65	72653	1	Plug, 3/8" N.P.T. Pipe
66	D24033	1	Thermometer, Plenum
67	D24123	1	Thermometer, Grain
68	77384	1	Booster, Spark
69	72035	3	Screw, No. 8 x 1/4" Metal
70	73100	1	Elbow, 1/2" T - 3/8" NPT x 90° Male
71	72673	1	Plug, 1/2" N.P.T. Pipe
72	73270	2	Grommet, 3/8" I.D. Rubber
73	72653	1	Plug, 3/8" Pipe
74	D25275	1	Bracket
75	72948	1	Elbow
76	D57242	1	Tube, Liquid
77	72787	1	Nipple, 3/8" x 4 1/2"
78	72595	1	Washer
79	90037	1	Connector Hose
80	72956	1	Tee, 3/8 x 3/8 x 3/8 N.P.T.
82	72780	1	Nipple, 3/8" Close
	72890	2	Bushing, 3/8" - 1/4" Red
90	74714	1	Decal, Operating Instruction
91	74715	1	Decal, Wiring Diagram
92	72620	2	Nipple, 1/4" Close
93	72885	1	Tee, 1/2" x 1/2" x 1/4"
94	73047	2	Elbow, 90° Brass, 1/4 T. to 1/4 M.N.P.T.
96	73962	1	Decal, Push to Start
97	74531 74615	1	Decal, Red Indicator
98	74530	1	Decal, Green Indicator
100	77162	4	Light, Indicator

NOTE: For nuts, washers and lockwashers - see page 90.

PROPANE CONTROL CABINET ASSEMBLY

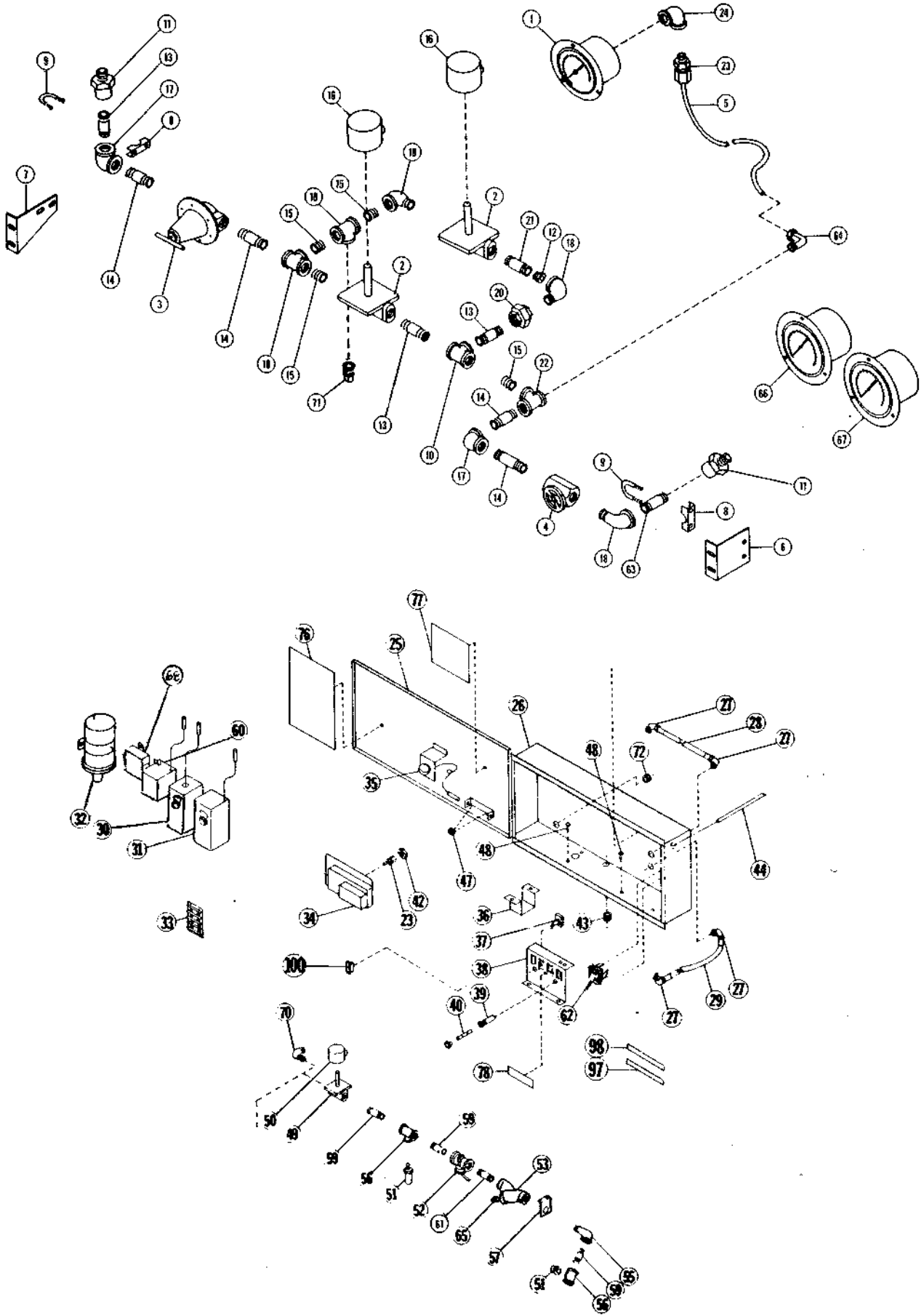

PROPANE CONTROL CABINET ASSEMBLY

REF. NO.	PART NO.	NO. REQ'D	DESCRIPTION
1	D25102	1	Gauge, Pressure
2	77193	2	Valve, $\frac{1}{2}$ " Solenoid
3	D25191	1	Regulator, $\frac{1}{2}$ " Pressure
4	57001285	1	Valve, Ball
5	D55310	1	Line, Pressure Guage
6	D25620	1	Bracket, Front Plumbing
7	D25631	1	Bracket, Rear Plumbing
8	D25610	2	Clamp, $\frac{1}{2}$ " Saddle
9	71987	2	U-Bolt
10	72886	3	Tee, $\frac{1}{2}$ "
11	73071	2	Connector, $\frac{1}{2}$ " T to $\frac{1}{2}$ " Pipe
12	D22415	1	Orifice
13	72792	3	Nipple, $\frac{1}{2}$ " x 2"
14	72791	4	Nipple, $\frac{1}{2}$ " x 1.5"
15	72790	4	Nipple, $\frac{1}{2}$ " close
16	D25542	2	Coil, Solenoid
17	72945	2	Elbow, $\frac{1}{2}$ "
18	72858	3	Elbow, $\frac{1}{2}$ " Street
19	72673	1	Plug, $\frac{1}{2}$ " Pipe
20	72978	1	Union, $\frac{1}{2}$ "
21	D25865	1	Nipple, Orifice
22	72886	1	Tee, $\frac{1}{2}$ " x $\frac{1}{2}$ " x $\frac{1}{2}$ "
23	73110	1	Connceptor, $\frac{1}{4}$ " T to $\frac{1}{4}$ " Pipe
24	72841	1	Elbow, $\frac{1}{4}$ " x 90 Degree
25	D25511	1	Door, Cabinet
26	D25503	1	Cabinet
27	73159	2	Connector, 3/8 Conduit x 90°
28	D25261	1	Conduit 16" Lg
29	D25263	1	Conduit, 12" Lg
30	D25770	1	Switch, Plenum
31	K25231	1	Thermostat, Grain Temperature
32	77228	1	Coil, Ignition, 12 Volt
33	77230	1	Block, Terminal
34	K25030	1	Switch, Air
35	73223	1	Light, Utility 12 Volt Only
36	D25251	1	Bracket, Solenoid
37	D25130	1	Switch, On-Off
38	D25212	1	Bracket, Switch
39	D25170	1	Holder, Fuse
40	77143	1	Fuse, 10 Amp
41	72093	2	Screw, No. 8 x 1" Metal
42	72279	1	Nut, 1" N.F. Hex Ham
43	73278	1	Grommet, 5/8 I.D. Rubber
44	D52321	1	Tube, Air Switch
	D22200	1	Wire, Tractor Lead-In

PROPANE CONTROL CABINET ASSEMBLY

REF. NO.	PART NO.	NO. REQ'D.	DESCRIPTION
47	73271	2	Grommet, 1/4" I.D. Rubber
48	71683	5	Screw, 10 - 24 x 1/2" Slotted Head Machine
49	77192	1	Body, 3/8" N.P.T. Solenoid Valve (2) FOR CSA
50	D25522	1	Coil, Solenoid valve 12 Volt
51	D25240	2	Valve, 1/4" N.P.T. Relief
52	D25120	1	Valve, 3/8" N.P.T. Quick Acting
53	D25280	1	Strainer, 3/8" N.P.T.
54	73085	1	Connector, 1/2" Tube to 3/8" . M.N.P.T. (CSA)
55	72857	1	Elbow, 3/8" N.P.T. Street (3) FOR CSA
56	72956	2	Tee, 3/8" N.P.T.
	72980	2	Bushing, 3/8" x 1/4" Red
57	D25271	1	Bracket, Plumbing
58	72784	1	Nipple, 3/8" N.P.T. x 3" X.H. CSA
59	72781	3	Nipple, 3/8" N.P.T. x 1 1/2" X.H.
60	D25161	1	Flame Detector
61	72782	1	Nipple, 3/8" x 2"
62	D25140	1	Switch, Push to Start
63	72793	1	Nipple, 1/2" x 2.5"
64	73128	1	Elbow, 1/4" to 1/2" NPT Brass
65	72653	1	Plug, 3/8" N.P.T. Pipe
66	D24033	1	Thermometer, Plenum
67	D24123	1	Thermometer, Grain
68	77384	1	Booster, Spark
69	72035	3	Screw, No. 8 x 1/4" Metal
70	73100	1	Elbow, 1/2" T - 3/8" NPT x 90° Male
71	72673	1	Plug, 1/2" N.P.T. Pipe
72	73270	2	Grommet, 3/8" I.D. Rubber
76	74714	1	Decal, Operating Instruction - Propane
77	74715	1	Decal, Wiring Diagram
78	73962	1	Decal, Push to Start
92	72620	2	Nipple, 1/4" Close
93	72885	1	Tee, 1/2" x 1/2" x 1/4"
94	73047	2	Elbow, 90° Brass, 1/4" T. to 1/4" M.N.P.T.
97	74531	1	Decal, Red Indicator
98	74530	1	Decal, Green Indicator
100	77162	4	Light, Indicator

NOTE: For nuts, washers and lockwashers - see page 90.

MICROPROCESSOR BOX ASSEMBLY

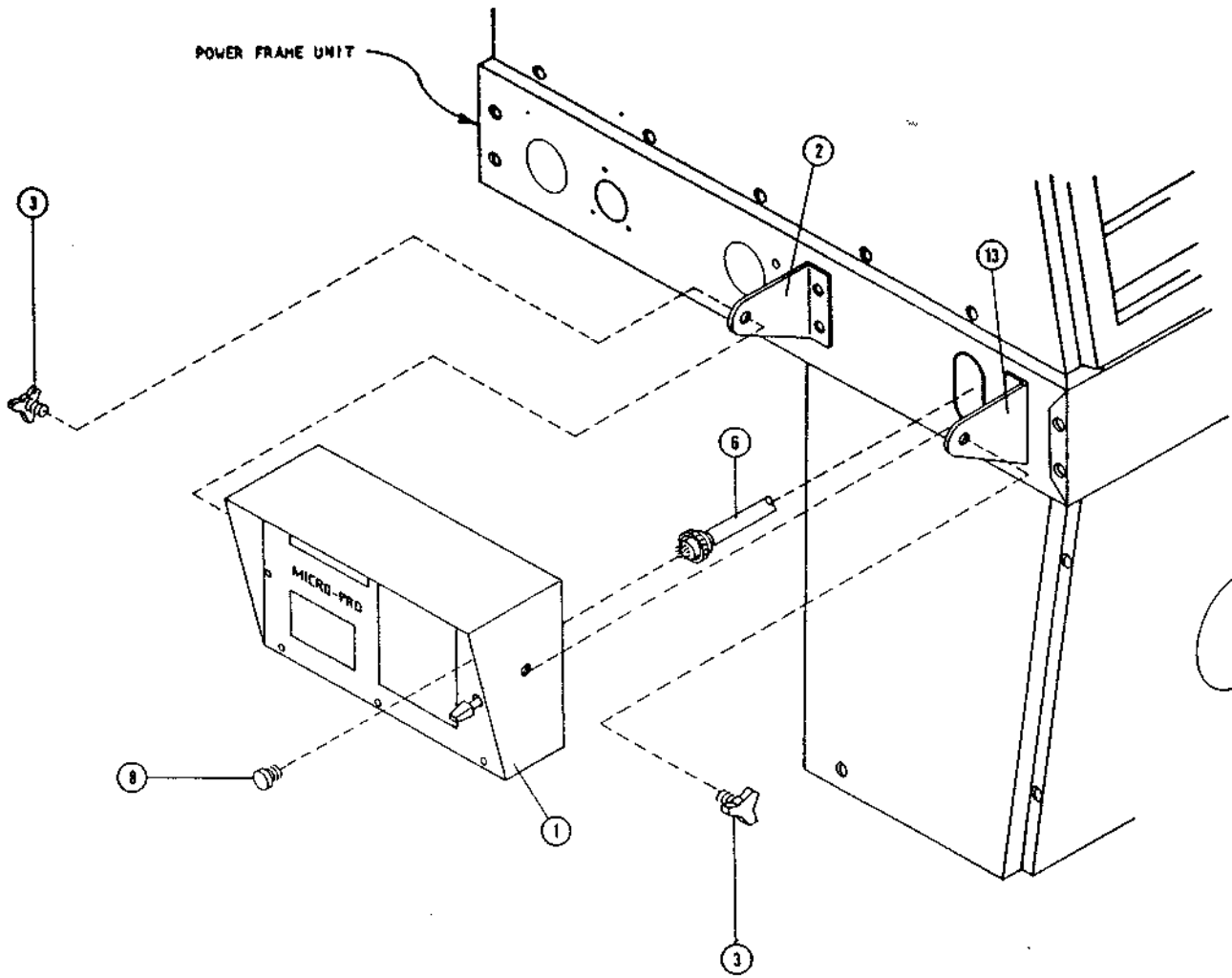

REF. NO.	PART NO.	NO. REQ'D.	DESCRIPTION
1	DA25001	1	Micro-Pro Assembly
2	D25845	1	Mount, Rear Box
3	77235	2	Knob, Adjusting
6	77264	1	Harness
8	S77239	1	Lamp
13	D25840	1	Mount, Front Box

FRAME ASSEMBLY

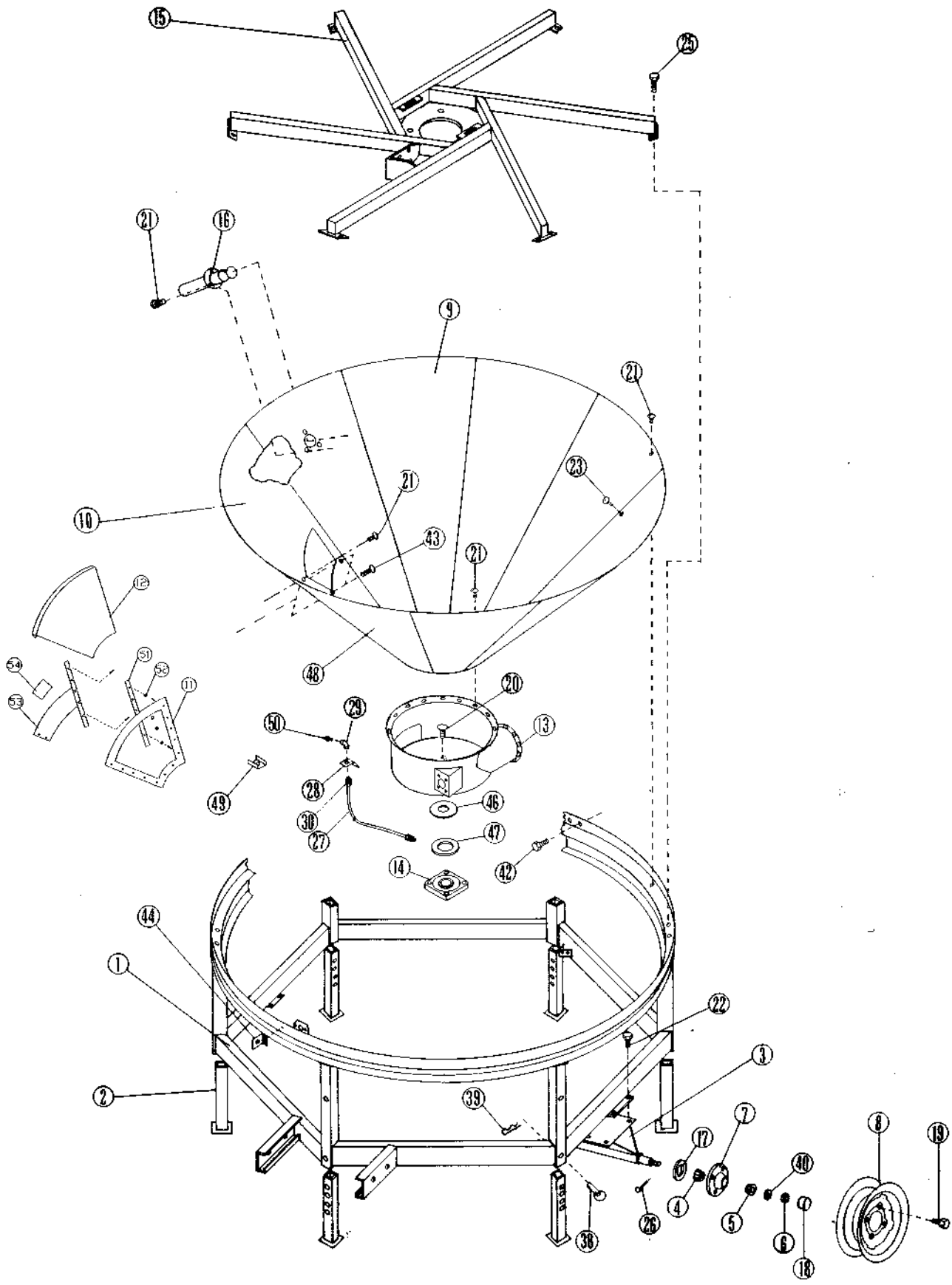

FRAME ASSEMBLY

REF. NO.	PART NO.	NO. REQ'D	DESCRIPTION
1	D51015	1	Main Welded Frame Less Hitch
2	D21021	6	Jack
	D21022	6	Adjustable Jack (Optional)
3	D51032	2	Axle Assembly
4	42-110149	4	Inner Bearing
5	D21050	4	Outer Bearing
6	D21060	4	Nut
7	D21075	4	Hub With Bearing Cups
8	D21080	4	Wheel Rim 15"
	D21085	4	Tire, Tube & Rim (Mounted)
9	D51450	8	Bin Bottom Sheet (Perf. Coated)
10	D51460	1	Bin Bottom Sheet w/Access Hole (Perf. Coated)
11	D21124	1	Access Door Frame
12	D21133	1	Access Door
13	D51144	1	Bin Bottom Well w/Boot
14	D21161	1	Bottom Auger Bearing
15	D51173	1	Spider
16	D21182	1	Grain Sampler
17	D21190	4	Seal
18	D21200	4	Cap
19	42-16053	16	Lug Bolt
20	71329	4	Carriage Bolt 1/2" x 1 1/2"
21	71823	129	1/4" - 20 x 1/2" Slotted HD Machine Screw
22	71103	8	1/2" x 1 1/2" Capscrew
23	71822	150	1/4" - 20 x 3/8" Slotted HD Machine Screw
25	71053	20	3/8" x 1 1/4" Capscrew
26	73527	4	5/32" x 1 1/4" Cotter Pin
27	73150	7 Ft.	3/16" Copper Grease Line (QF Only)
27	D51190	1	Line, Grease
28	D21220	1	Bracket, Line
29	72840	1	Elbow, 1/8"
30	73109	2	1/8" Compression Fittings
38	73586	6	Pin
39	73587	6	Clip
40	72474	4	3/4" Washer
42	71054	2	3/8" x 1 1/2" Capscrew
43	71825	2	1/4" - 20 x 3/4" Slotted Head Machine Screw
44	D22491	1	Bracket, Conduit
46	73289	1	Seal, 2" I.D. Neoprene Shaft
47	73290	1	Seal, 2.72" I.D. Neoprene Bearing
48	D51400	1	Bin Bottom Sheet (Solid)
49	D29560	3	Clip (QF Only)
50	73332	1	Zerk, 1/8" N.P.T. Female (QF Only)
50	42-16127	1	Zerk, 1/8" Grease
51	D21500	1	Track
52	72488	6	Washer, Hi-Lock
53	D21136	1	Bar, Safety
54	74716	1	Decal

NOTE: For nuts, washers and lockwashers - see page 90.

AGITATOR ASSEMBLY

TOP VIEW

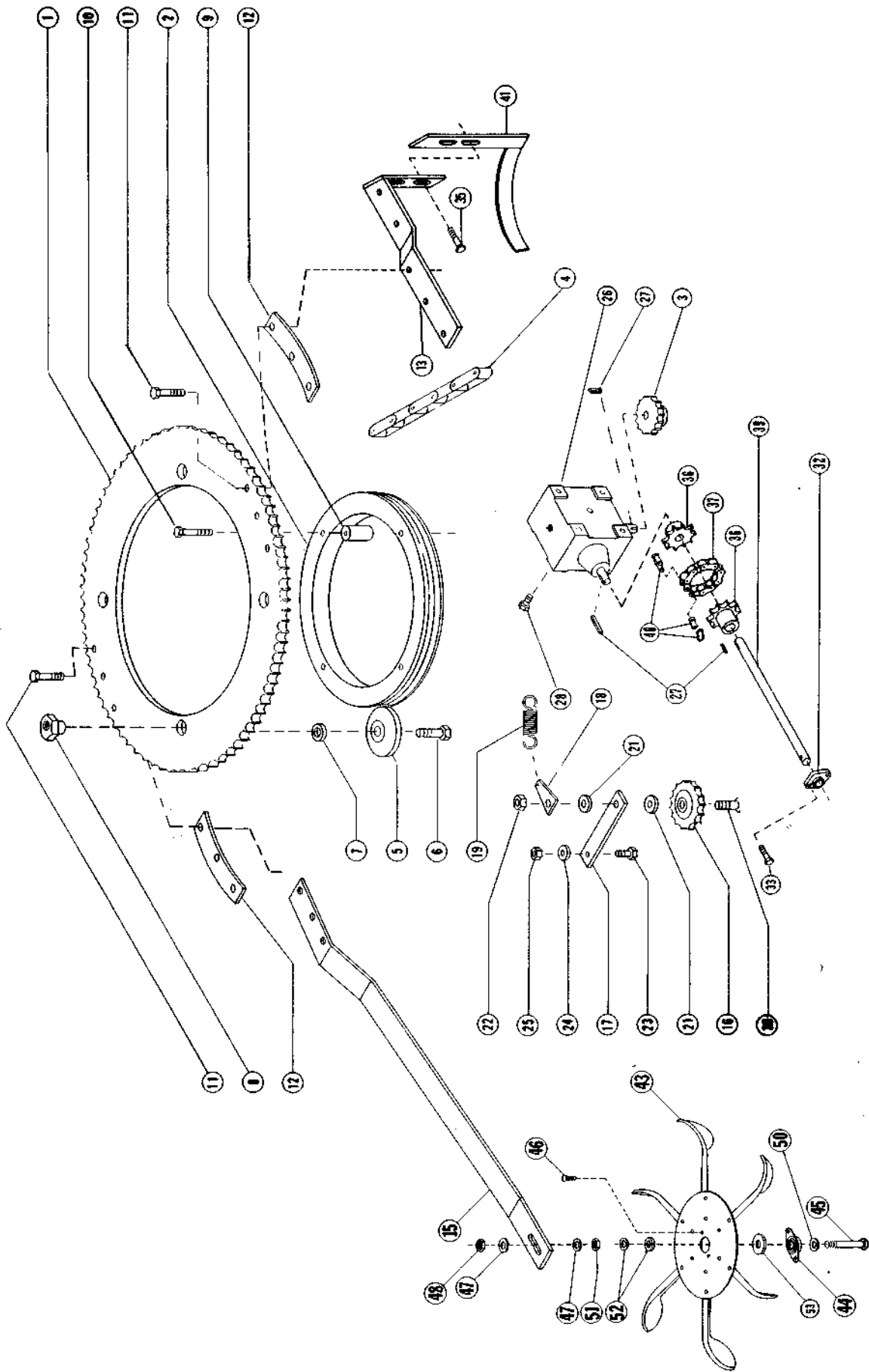

AGITATOR ASSEMBLY

REF. NO.	PART NO.	NO. REQ'D	DESCRIPTION
1	D28033	1	Sprocket, No. 60, 112 Teeth
2	D28260	1	Race, Agitator
3	D28090	1	Sprocket, No. 60, 13 Teeth
4	D28141	1	Chain, No. 60 Roller 128 Pitches
5	D28161	4	Roller, Agitator w/Bearings
	A28000	4	Roller Brg. Kit
6	73521	4	Capscrew, 3/4" x 2 3/4" HT
7	72522	4	Washer
8	D28204	4	Nut, Cam
9	D28270	4	Spacer
10	73519	4	Capscrew, 7/16" x 5" HT
11	73504	6	Capscrew, 7/16" x 2 1/2" HT
12	D28082	4	Spacer, Agitator Arm
13	D58212	1	Arm, Horiz. Sect. Vertical Agitator (Standard)
15	D58064	1	Arm, Horizontal Agitator
16	D28172	1	Sprocket, No. 60 Idler 15 Teeth
17	D28181	1	Arm, Idler
18	D28280	1	Tab, Spring
19	D28190	1	Spring
20	71132	1	Capscrew, 5/8" x 2 1/2"
21	72413	2	Washer, 5/8"
22	72376	1	Nut, 5/8" Lock
23	71103	1	Capscrew, 1/2" x 1 1/2"
24	72412	1	Washer, 1/2"
25	72379	1	Nut, 1/2" Lock
26	D28241	1	Gearbox
27	73400	3	Key, 1/2" Square x 1 1/2" Lg.
28	71052	4	Capscrew, 3/8" x 1 1/2"
32	D28290	1	Bearing w/Collar
33	71029	2	Capscrew, 5/16" x 1 1/2"
35	71331	2	Bolt, 1/2" x 2" Carriage
36	D28335	2	Coupler Half, 60B 10 x 1"
37	D28331	1	Chain, No. 60 Roller 9 Pitch
39	D58126	1	Shaft, Agitator (QF Model)
39	D58125	1	Shaft, Agitator
40	73368	1	Link, No. 60 Roller Chain Connecting
41	D58230	1	Paddle, STD Vertical Agitator Arm (Inner)
43	D58080	1	Wheel, Rotary Agitator (Ass'y)
	D58160	1	Disc (For above)
	D58170	6	Paddle (For above)
44	85020	1	Bearing, 3/4"
45	75342	1	Capscrew, 3/4" x 4"
46	71051	2	Bolt, 3/8" x 3/4"
47	72591	2	Washer, 3/4" Wide Rim
48	72375	1	Nut, 3/4" Hex Lock
50	72595	1	Bushing, 3/4" NR Machine
51	72256	1	Nut, Jam
52	D28370	2	Bushing, 3/4" Machine (Thick)
53	72415	1	Washer, 7/8"

NOTE: For nuts, washers and lockwashers - see page 90.

AGITATOR SENSOR ASSEMBLY

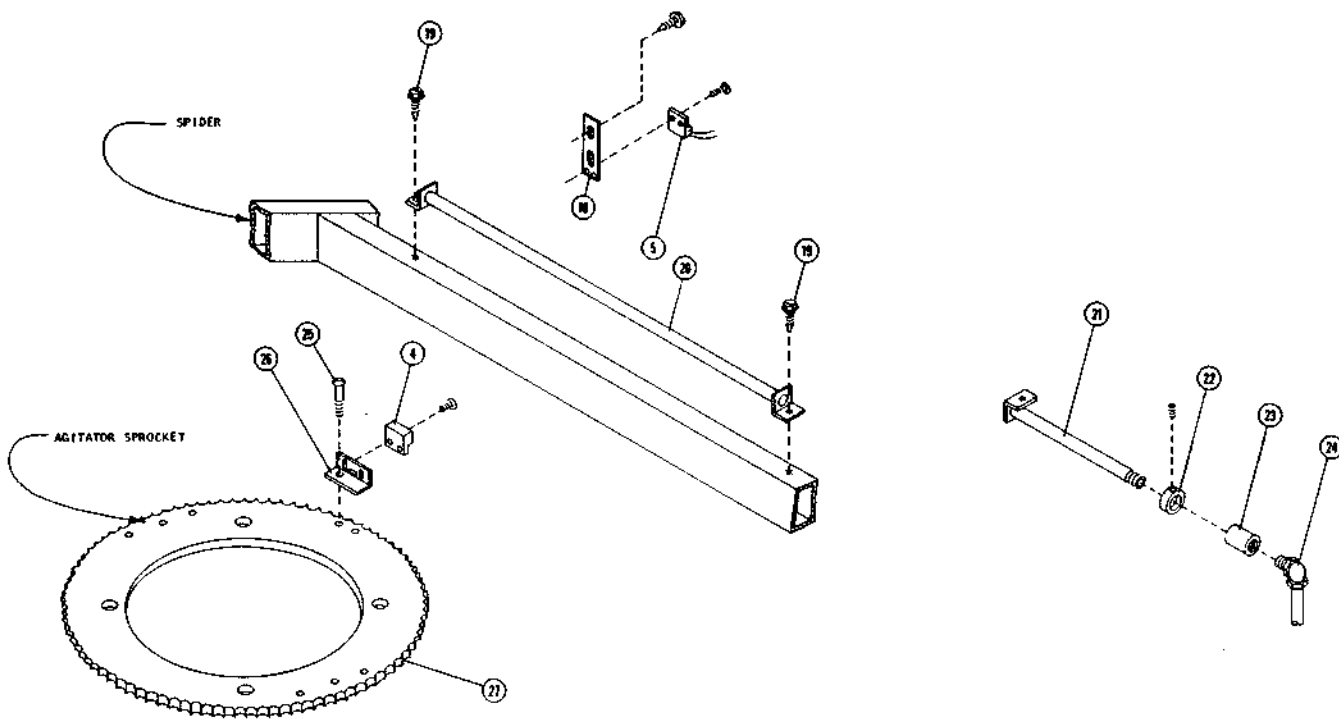

REF. NO.	PART NO.	NO. REQ'D.	DESCRIPTION
* 4	77247	1	Magnet
* 5	77248	1	Sensor, Pickup
*18	D25790	1	Bracket, Agitator Sensor Mtg.
*19	71942	3	Screw, # 14 x 3/4"
*20	D24250	1	Pipe, Agitator Sensor Spider
21	D24260	1	Pipe, Agitator Sensor Grain Wall
22	D22130	1	Collar Set
23	72836	1	Coupler, 1/2"
24	73159	1	Elbow, 3/8" Conduit
*25	71688	1	Screw, #10 x 3/4"
*26	D25900	1	Angle, Agitator Sensor Mtg.
27	D28033	1	Sprocket, Agitator

* Micro-Pro Only

**GEARBOX ASSEMBLY
GT D28241**

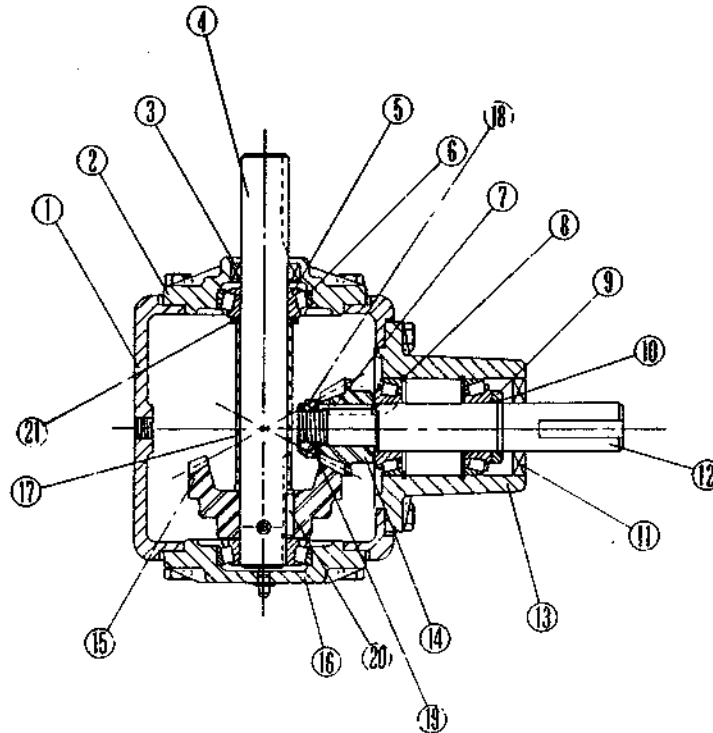

Identification No. D28241 is located on a metal tag under cap bolt.

REF. NO.	PART NO.	DESCRIPTION
1	77400	Housing
2	42-16144	Cap
	42-16152	Sems Cap Screws
3	42-16146	Seal
4	77401	Shaft
5	42-16147	Bearing Cone
6	42-16148	Bearing Cup
	42-16155	Gasket (.015)
	42-16156	Gasket (.005)
7	77402	Key
8	77403	Retaining Ring
9	77404	Collar
10	77405	Retaining Ring
11	77406	Seal
12	77414	Shaft
13	77408	Cap
14	77079	Gear
15	77080	Gear
16	77412	Cap
17	42-90058	Spacer
18	77410	Locknut
19	77409	Washer
20	77411	Key
21	42-90057	Washer
	42-16151	Roll Pin
	77413	Pipe Plug (Solid)
	72924	Relief Valve
	72921	Reducer

PLENUM ASSEMBLY

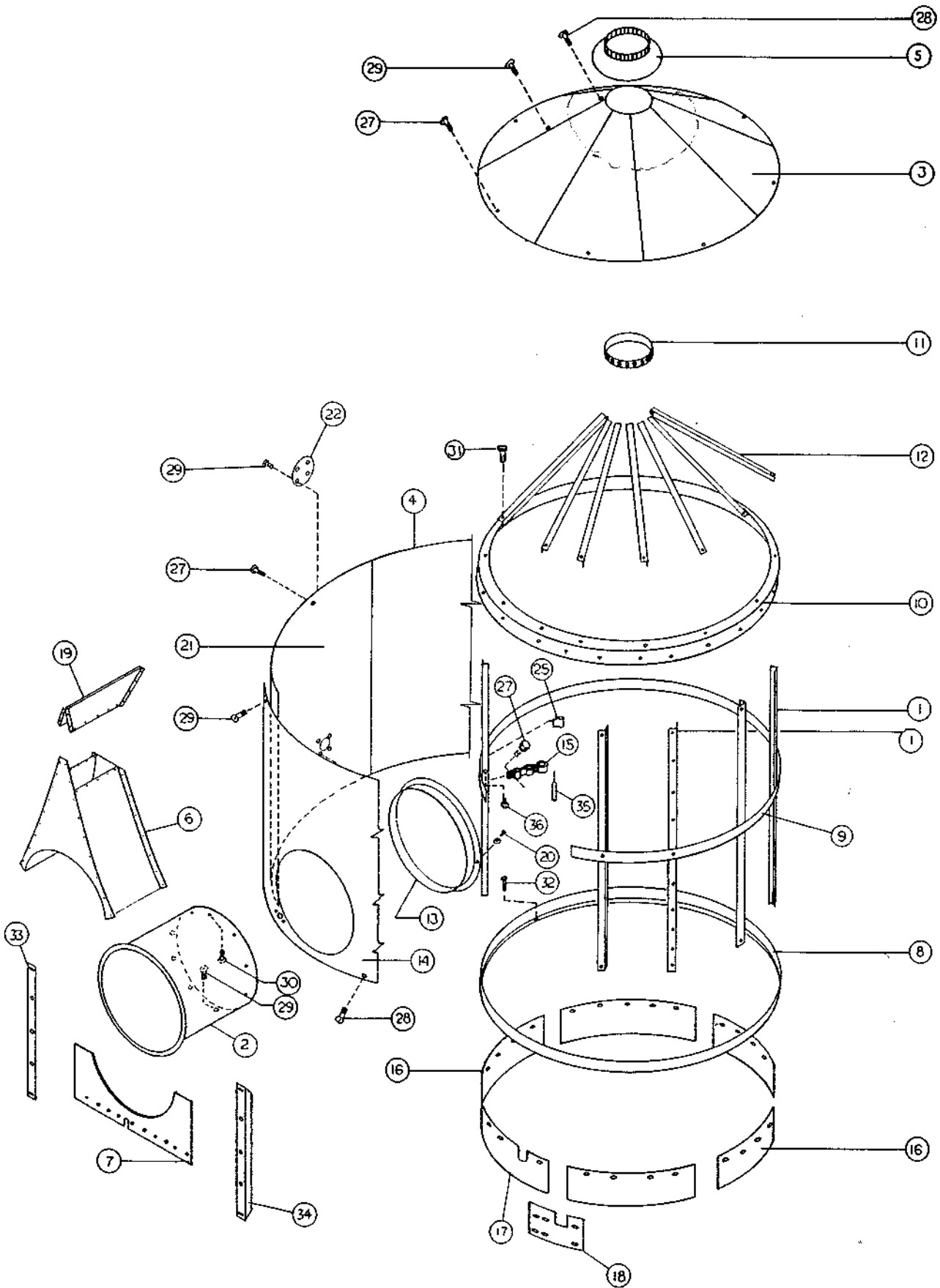

PLENUM ASSEMBLY

REF. NO.	PART NO.	NO. REQ'D.	DESCRIPTION
1	D33010	31	Plenum Frame Angle, Straight
2	D53020	1	Connecting Tube
3	D53341	7	Lid Sheet
4	D53040	4	Side Sheet Without Connecting Tube Hole
5	D23051	1	Cone Cap
6	D53061	1	Saddle
7	D53070	1	Front Enclosure
8	D53080	1	Lower Frame Band
9	D53091	1	Center Band, 1/8" Thick
10	D53100	1	Transition Band
11	D53110	1	Top Ring
12	D53120	35	Lid Frame Angles
13	D53130	1	Connecting Tube Trim Ring
14	D53360	SD 1	Sheet With Connecting Tube Hole
	D53150	1	Side Sheet (Narrow Strip)
15	D23161	2	Thermometer Support Bracket
16	D53172	5	Skirt
17	D53182	1	Skirt With Slot
18	D53192	6	Splices, Plenum Skirt
19	D53160	1	Extension, Saddle
20	71942	11	No. 14 x 3/4" Self Tapping Screw
21	D53210	1	Side Sheet W/Cleaner Hole
22	D24210	1	Plate, Cover
25	D23210	2	Push on Clip
27	71823	85	1/4" - 20 x 1/2" Slotted Hd Machine Screw
28	71825	108	1/4" - 20 x 3/4" Slotted Hd Machine Screw
29	71822	104	1/4" - 20 x 3/8" Slotted Hd Machine Screw
31	71001	35	1/4" x 3/4" Capscrew
32	72155	6	5/16" x 3/4" Self-tapping Hex Hd Screw
33	D54320	1	Stiffener, Front Sheet, Right
34	D54330	1	Stiffener, Front Sheet, Left
*35	77271	1	Sensor, Temperature Plenum
36	77886 77567	1	Sensor, High Limit Control
	D23230		

* Micro-Pro Only

AUGER ASSEMBLY

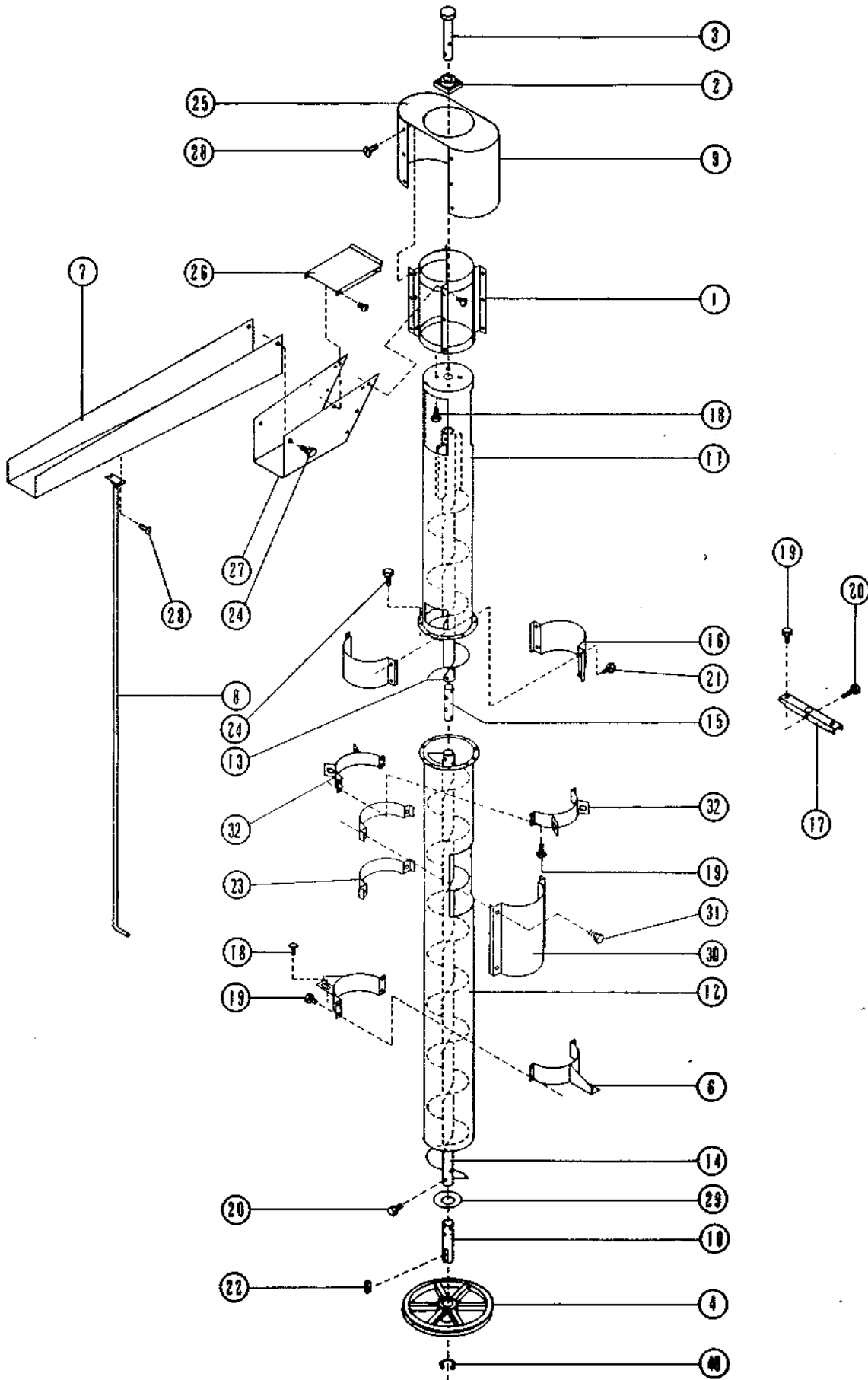

AUGER ASSEMBLY

REF. NO.	PART NO.	NO. REQ'D.	DESCRIPTION
1	D26013	1	Swivel Head
2	D21161	1	2" Flange Bearing
3	D26020	1	Upper Stub Shaft
4	D26030	1	Sheave 1C 18" x 2"
6	D26065	2	Clamp, Support (at Spider)
7	D36071	1	Spout
8	D36081	1	Spout Control Handle
9	D26091	1	Head Baffle, Side
10	D26101	1	Lower Stub Shaft
11	D36111	1	Auger Tube (Top Section)
12	D56120	1	Auger Tube (Bottom Section)
13	D36131	1	Fighting (Top Section)
14	D36141	1	Fighting (Bottom Section)
15	D26150	1	Stub Connecting Shaft
16	D26162	2	Inspection Hole Cover
17	D26170	1	Split Auger Support
18	71329	6	1/2" x 1 1/2" Carriage Bolt
19	71056	8	3/8" x 2" Capscrew
20	73520	8	5/8" x 3 1/2" Capscrew
21	71001	4	1/4" x 3/4" Capscrew
22	73417	1	1/2" x 1/2" x 1 1/2" Key
23	D41030	2	Cleaning Attachment Band
24	71052	12	3/8" x 1" Capscrew
25	D26180	1	Head Baffle, Top
26	D26190	1	Head Baffle, Spout Cover
27	D26200	1	Head Baffle, Spout
28	71825	26	1/4" - 20 x 3/4" Slotted HD Machine Screw
29	72424	1	2" Washer
30	D26220	1	Grain Cleaner Hole Cover
31	71054	4	3/8" x 1 1/2" Capscrew
	DA26000	1	Includes Item Number 1, 9, 25, 26, 27 Assembled
	73180	1	Fighting Repair Section
32	D26057	2	Clamp, Brace
40	69503	1	Snap Ring

NOTE: For nuts, washers and lockwashers - see page 90.

OUTSIDE SKIN ASSEMBLY

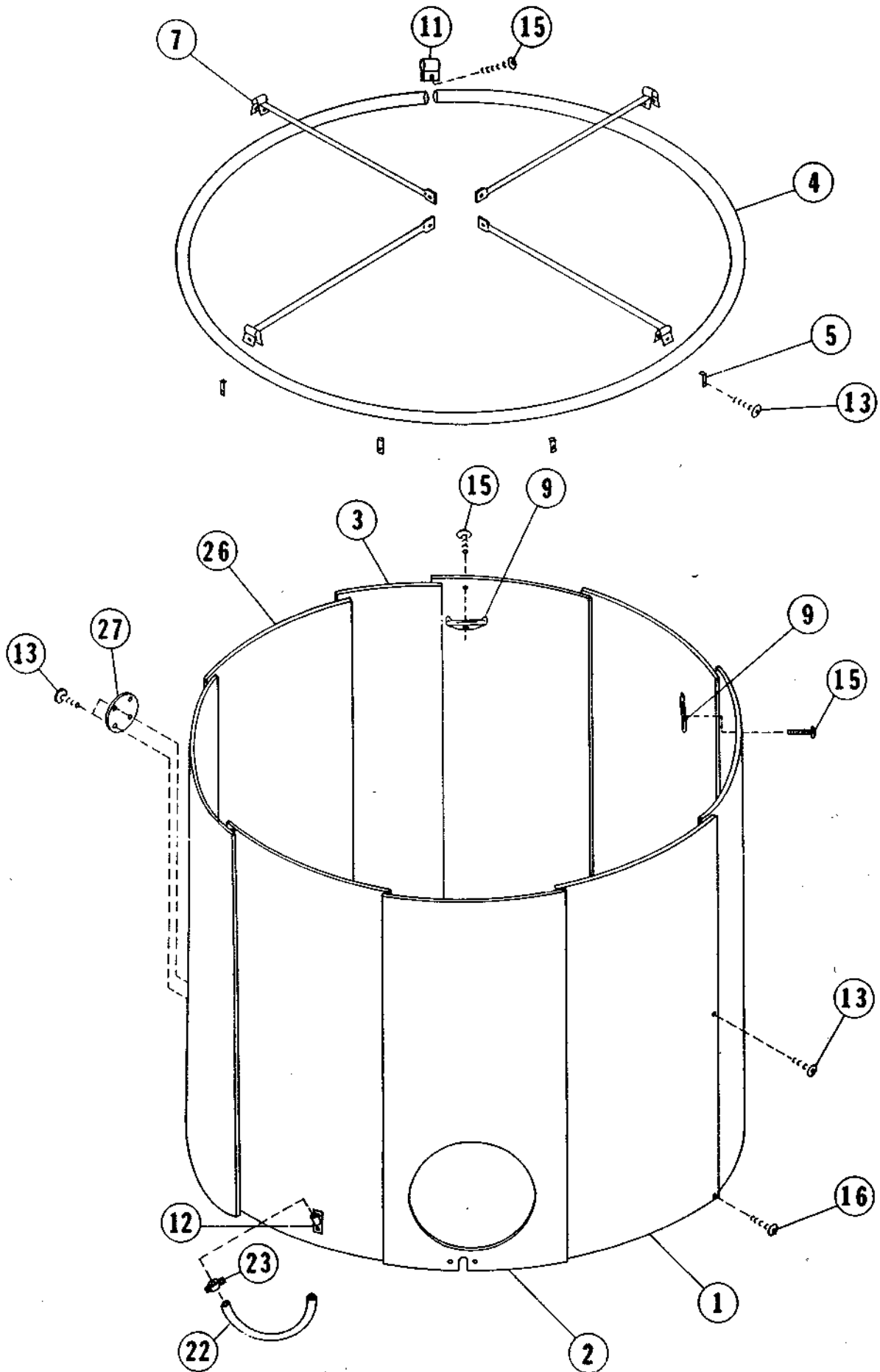

OUTSIDE SKIN ASSEMBLY

REF. NO.	PART NO.	NO. REQ'D.	DESCRIPTION
1	D54260	6	Outside Sheet Fine Perforated
2	D54240	1	Outside Sheet with Hole Fine Perforated
3	D54270	1	Outside Sheet 34" Wide Fine Perforated
4	D54040	1	Cap Ring
5	D24050	8	Ring Holder
7	D54072	4	Auger Brace
8	D24080	1	Spout Control Catch
9	D24091	2	Spout Support
11	D24110	1	Rim Connector
*12	D24240	1	Grain Temperature Capillary Support Bracket
12	D24131	1	Grain Temp Capillary Bracket
13	71822	220	1/4" - 20 x 3/8" Slotted Hd Machine Screw
15	71825	12	1/4" - 20 x 3/4" Slotted Hd Machine Screw
16	71823	105	1/4" - 20 x 1/2" Slotted Hd Machine Screw
*22	D25262	1	Liquitite Conduite
22	D54191	1	Conduit
23	73263	1	3/4" Two Screw Connector
26	D54250	1	Outside Sheet w/Hole for Grain Cleaner-Fine Perf.
27	D24210	1	Cover Plate
	73966	1	(GT Logo)

*GRAIN CAPILIARY ASSEMBLY

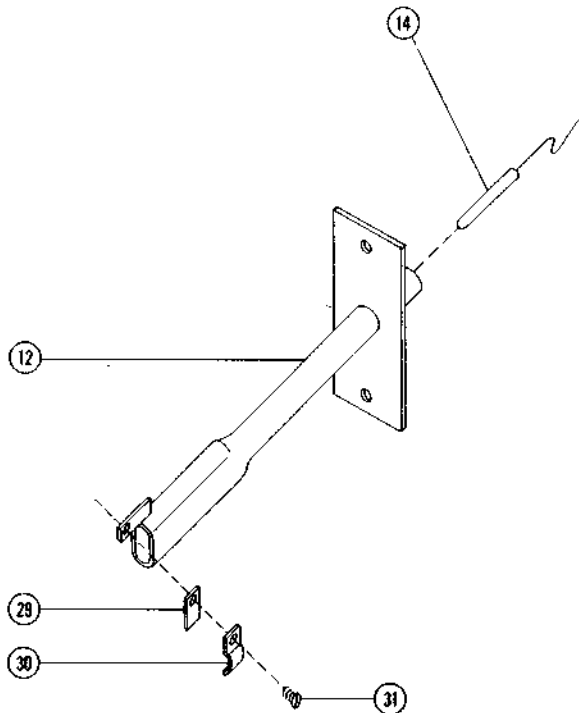

REF. NO.	PART NO.	NO. REQ'D.	DESCRIPTION
12	D24240	1	Bracket, Grain Temp Sensor
14	77271	1	Sensor, Grain Temperature
29	D24270	1	Strip, Clamping
30	73486	1	Clip, Jiffy
31	71685	1	Screw, #10 - 24 x 3/4

* Micro-Pro Only

PELMET KIT - 500 BUSHEL

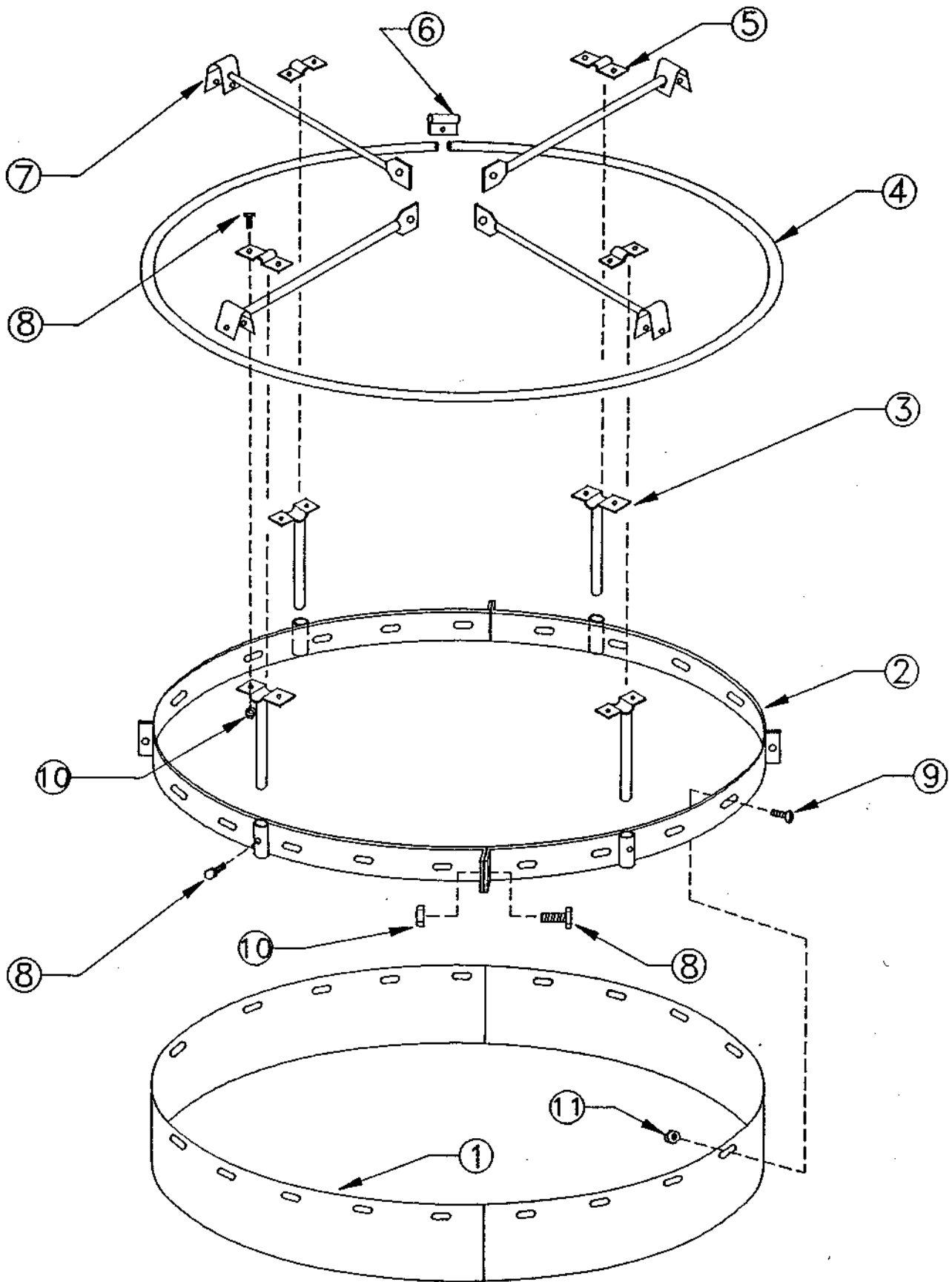

PELMET KIT - 500 BUSHEL

REF. NO.	PART NO.	NO. REQ'D.	DESCRIPTION
1	D53230	4	Skirt, Pelmet
2	D53240	4	Ring, Pelmet
3	D53250	4	Leg, Pelmet
4	D54040	1	Ring, Cap
5	502360	4	Clamp, Pelmet Leg
6	D24110	1	Connector, Rim
7	D54072	4	Brace
8	71052	20	Capscrew, 3/8 x 1
9	71825	28	Screw 1/4-20 x 3/4 O/T SL HD
10	72210	20	Nut, 3/8 Hex
11	72382	28	Nut, Whiz Lock 1/4
	72440	20	Washer, 3/8 Lock

LOADING HOPPER & DRIVE ASSEMBLY

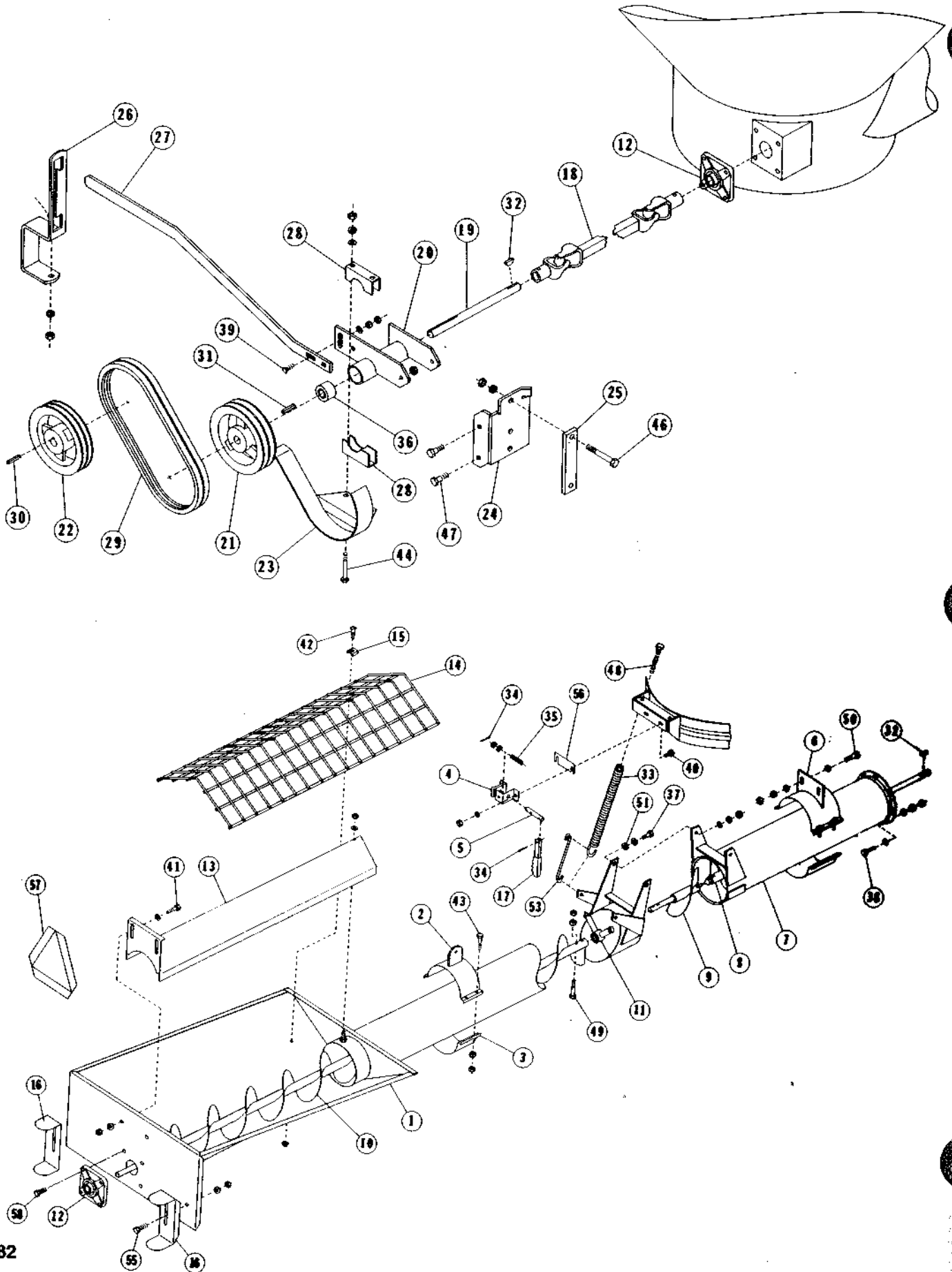

LOADING HOPPER & DRIVE ASSEMBLY

REF. NO.	PART NO.	NO. REQ'D	DESCRIPTION
1	D29013	1	Hopper, Extended
2	D59540	1	Catch, Hopper
3	41-10143	1	Band, Half
4	D29521	1	Latch, Hopper
5	D29540	1	Pin, Latch
6	D59141	1	Mount, Tube
7	D59031	1	Tube, Front Auger
8	D59053	1	Flight, Front Auger
9	D59391	1	Flight, Short Sec. Rear Auger
10	D29042	1	Flight, Long Sect. Rear Auger
11	42-98080	1	Bearing & Casting
	71127	1	Capscrew, 5/8 x 1
	D29510	1	Bolt w/Zerk
	42-18183	1	Bronze Bearing
12	42-66022	2	Bearing
13	D59150	1	Regulator, Grain Flow
14	D29471	1	Grill, Hopper
15	D29560	4	Clip, Grill
16	D29161	2	Stand, Hopper
17	D29531	1	Latch Handle
18	D59343	1	Tumbler (See page 44 for parts)
19	D22850	1	Jackshaft
20	D29490	1	Housing, L.H. Jackshaft
21	D59311	1	Pulley, 6.6 PD x 1" ID
22	D59301	1	Pulley, 6.6 PD x 1½ ID
23	D29372	1	Guard, Belt
24	D29352	1	Bracket, Jackshaft
25	D52720	1	Strap
26	D57215	1	Lock, Clutch Handle (QF Only)
26	D59382	1	Lock, Clutch Handle
27	D59363	1	Handle, Clutch (QF Only)
27	D59362	1	Handle
28	42-16453	2	Clamp, Mount
29	D59322	1	Belt, B58 (Set of 2)
30	73411	1	Key, 3/8 x 3/8 x 1½
31	42-66057	1	Key, ½ x ½ x 1½
32	42-18282	2	Key, No. 808 Woodruff
33	73317	2	Spring, Lift
	D29480	2	Spring, Lift w/plug nut
34	73534	2	Pin, Cotter, 1/8 x 1½
35	73316	1	Spring, Pin
36	42-16334	2	Bearing, 1"
37	71079	2	Capscrew, 7/16 x 1½
38	71027	8	Capscrew, 5/16 x 1
39	71277	1	Bolt, Carriage 3/8 x 1
40	71251	8	Bolt, Carriage 5/16 x 3/4
41	71026	2	Capscrew, 5/16 x 3/4
42	71825	4	Screw, 5/16 x 3/4 SL HD Machine
43	71054	8	Capscrew, 3/8 x 1½
44	71038	2	Capscrew, 5/16 x 4½
46	71112	2	Capscrew, ½ x 4
47	71103	2	Capscrew, ½ x 1½
48	71988	2	Capscrew, ½ x 6 Full Thd.
49	71083	2	Capscrew, 7/16 x 2½
50	71329	2	Bolt, Carriage ½" x 1½"
51	D29020	2	Spacer, ½" ID x 1" OD x 5/16"
52	71303	1	Bolt, Carriage, 7/16" x 1½"
53	D59172	2	Rod, Spring Connecting
55	71051	2	Capscrew, 3/8" x 3/4"
56	D29550	As Req'd.	Spacer, Hopper Latch
57	73899	1	Decal, Slow Moving Vehicle
58	71053	8	Capscrew, 3/8" x 1½"
59	73109	2	Fitting, 3/16" T to 1/8" N.P.T.
60	73332	2	Zerk, 1/8" N.P.T. Female
61	73150	6 ft.	3/16" Copper Grease Line

NOTE: For nuts, washers and lockwashers - see page 90.

9' HOPPER PARTS

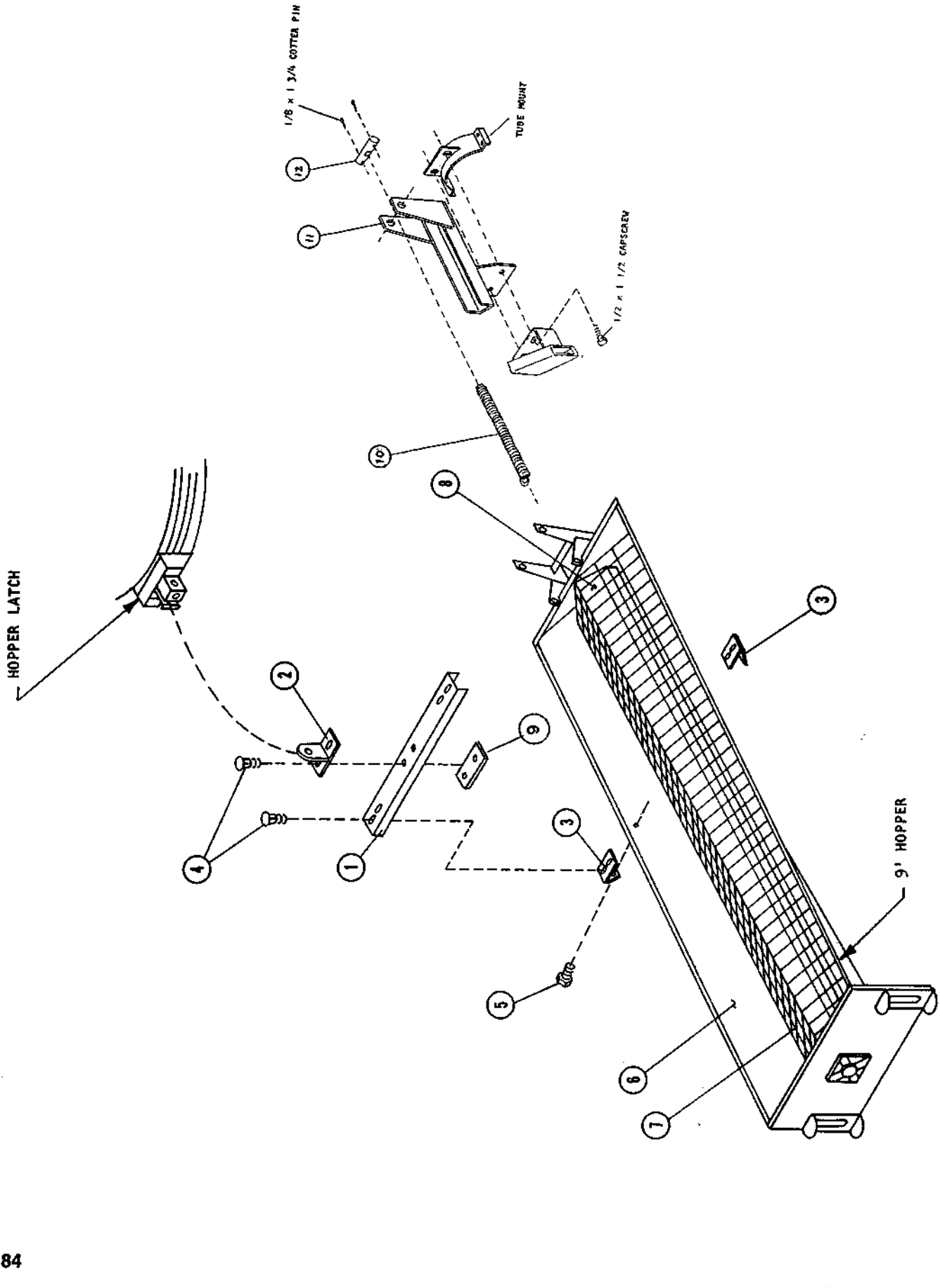

9' HOPPER PARTS LIST

REF. NO.	PART NO.	NO. REQ'D.	DESCRIPTION
1	D29750	1	Channel
2	D29740	1	Catch
3	D29730	2	Hook
4	71252	6	Bolt, 5/16 x 1 Carriage
5	71027	2	Capscrew, 5/16 x 1
6	D29710	1	Hopper, 9'
7	D29476	1	Grill, Hopper
8	D29720	1	Regulator, Grain
9	D29755	1	Plate, Channel
10	D29480	1	Spring w/Nut
11	D59860	1	Channel, Mtg.
12	D29870	1	Pivot, Hopper Spring

GRAIN CLEANING ATTACHMENT

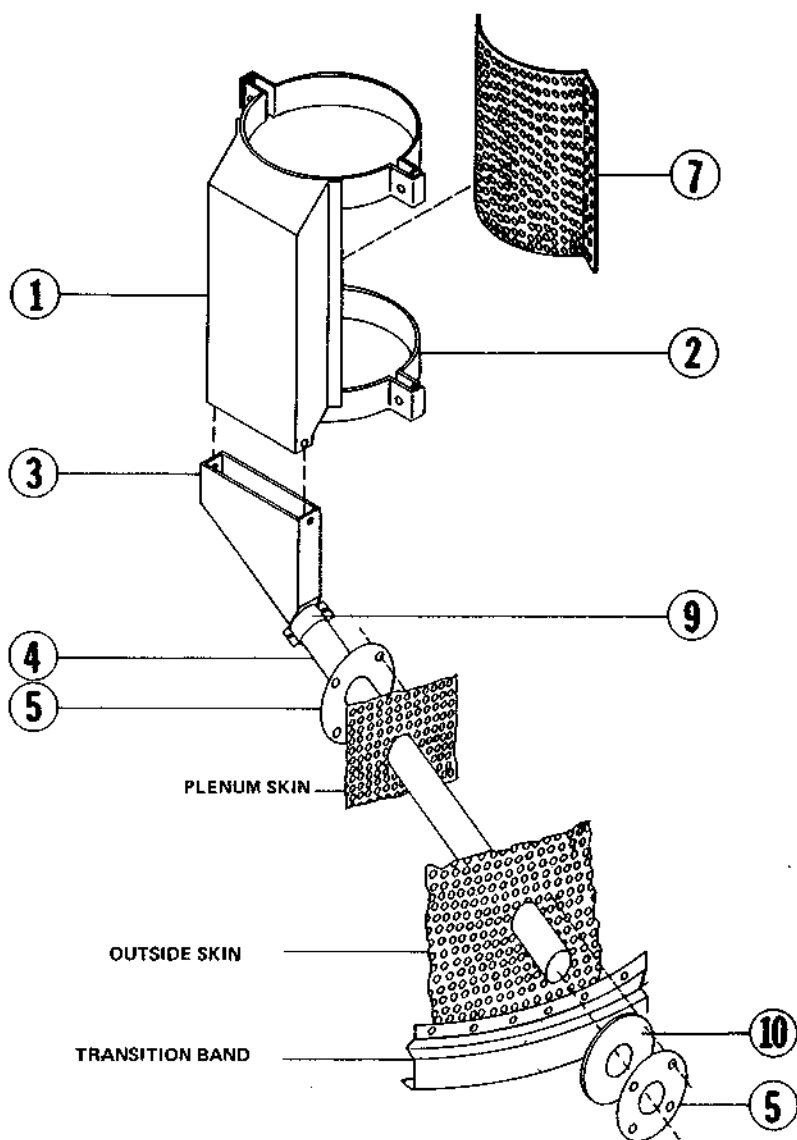

REF. NO.	PART NO.	NO. REQ'D.	DESCRIPTION
	A41011	1	Grain Cleaning Attachment
1	D41020	1	Cleaning Attachment Body
2	D41030	2	Cleaning Attachment Bands
3	D41082	1	Cleaning Attachment Transition
4	D41090	1	Cleaning Attachment Top Tube
5	D41100	1	Flange, Cleaning Attachment Tube
7	A41100	1	Cleaning Attachment Screen (Corn, Sunflower) 7/32" Holes
7	A41110	1	Cleaning Attachment Screen (Wheat, Oats, Barley, Milo) 7/64" Holes
7	A41120	1	Cleaning Attachment Screen (Soybeans) 5/32" Holes
7	A41130	1	Cover Plate (To replace screen)
7	A41105	1	Cleaning Attachment Screen (Flax) 5/64" Holes
7	A41115	1	Cleaning Attachment Screen (Rape Seed) 1/16" Holes
9	D41081	1	Band, Transition 1/2
10	73289	1	Seal, Rubber

HYDRAULIC UNLOAD HEAD

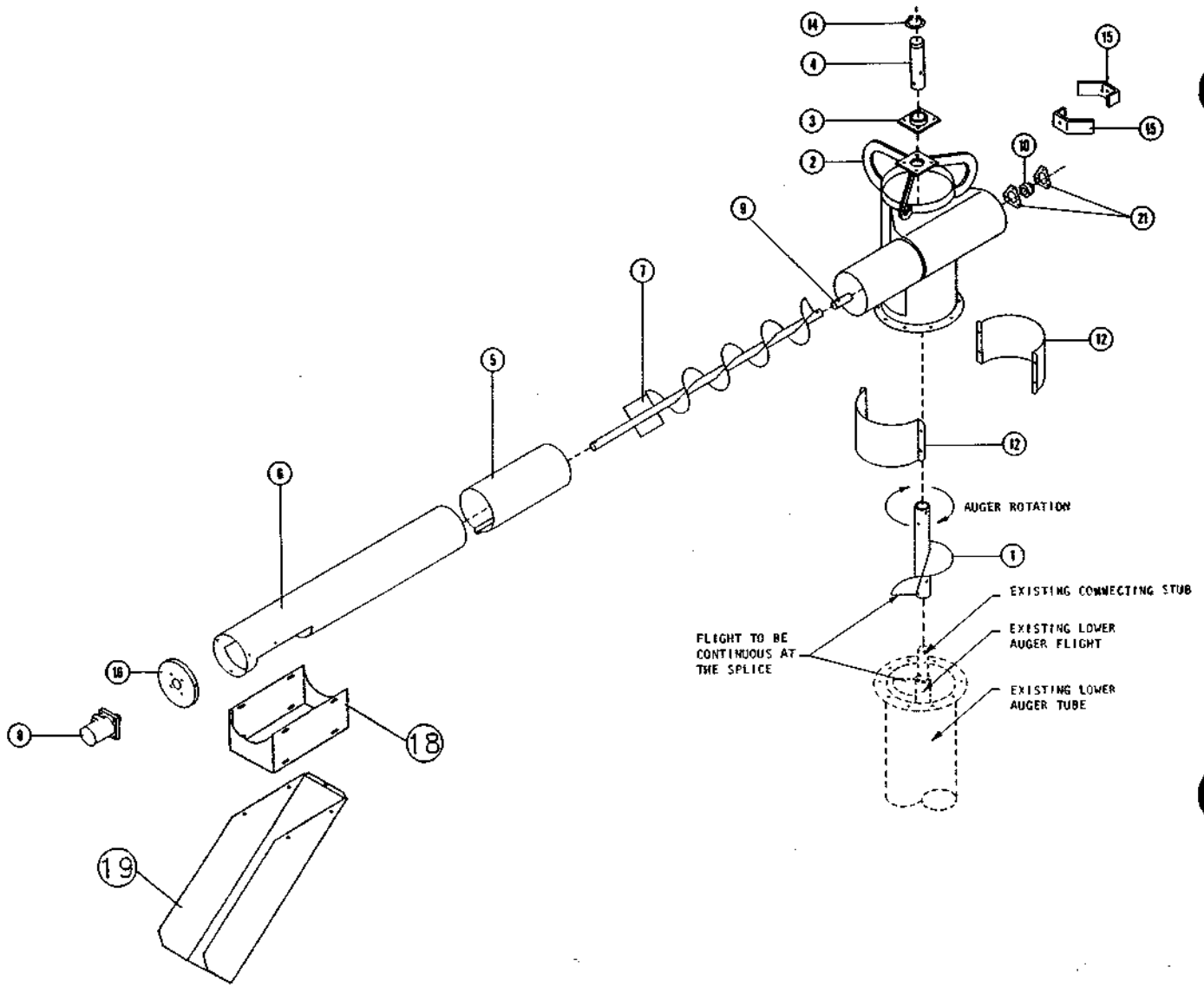

ELECTRIC UNLOAD HEAD

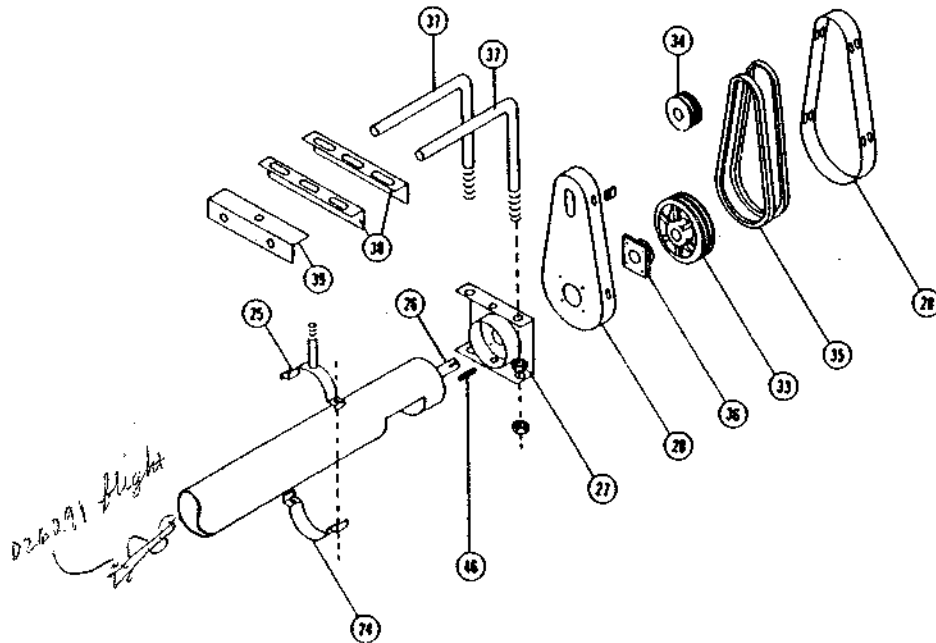

HYDRAULIC & ELECTRIC UNLOAD HEAD PARTS LIST

REF. NO.	PART NO.	NO. REQ'D.	DESCRIPTION
1	D26311	1	Auger, Horiz. Unload, Vertical
2	D26282	1	Head, Top Auger
3	D21161	1	Bearing, 2" Flanged
4	D26021	1	Stub, Top Auger
5	42-58080	1	Band, 8" x 14½" Connecting
6	D26305	1	Housing, Horiz. Unload Auger
7	D26295	1	Flight, Horiz. Unload Auger
8	D26270	1	Motor, M202 Hydraulic
9	42-56211	1	Stub, Flight Shaft
10	85000	1	Bearing, 1"
12	D26162	2	Band, Inspection Hole
14	69503	1	Snap Ring
15	D26441	2	Spreader, Grain
16	D26255	1	End Cap
18	D26265	1	Adapter, Spout
19	D26326	1	Spout, Top Unl. Head
21	42-54054	1 Pair	Retainer, Bearing
23	71051	7	Capscrew, 3/8" x ¾"
24	41-10042	3	Half Band 8"
25	42-58082	1	Band, Rear Motor Support
26	42-58037	1	Stub, Head
27	42-58049	1	Plate, Head
28	42-58081	1	Guard, Belt
33	42-90025	1	Pulley, 2B 10" x 1¼"
34	75044	1	Pulley, 2B 3" x 24mm
35	42-58076	1 2	Belt, B48 (Set of 2) B40
36	42-58052	1	Bearing
37	42-58046	2	Rod, Motor Mounting
38	42-58048	1	Strap, Motor Mount w/Nuts
38	42-58091	1	Strap, Motor Mount
39	42-58083	1	Angle, Rear Motor Support
46	42-58050	1	Key



35 D26291
 40 D26580
 40 D26312

Flight
 Housing Head
 Auger Vack

NUTS, WASHERS AND LOCKWASHERS

PART NO.	DESCRIPTION	PART NO.	DESCRIPTION
72208	1/4" Nut	72438	1/4" L-Washer
72209	5/16" Nut	72439	5/16" L-Washer
72210	3/8" Nut	72440	3/8" L-Washer
72211	7/16" Nut	72441	7/16" L-Washer
72212	1/2" Nut	72442	1/2" L-Washer
72213	5/8" Nut	72443	5/8" L-Washer
72380	1/4" L-Nut	72408	1/4" Washer
72379	1/2" L-Nut	72409	5/16" Washer
72375	3/4" L-Nut	72410	3/8" Washer
72382	1/4" Whiz Lock-Nut	72411	7/16" Washer
72334	1/4" Tinnerman Nut	72412	1/2" Washer
72376	5/8" Lock Nut	72413	5/8" Washer
72195	#4 Nut	72486	#4 Nylon Washer
72204	#10 Nut	72434	#10 L-Washer

TORQUE ALL BOLTS PER TORQUE SPECIFICATION CHART

COARSE THREAD FASTENER	GRADE DESIGNATION	SCREW, STUD, OR BOLT SHANK SIZE OR DIAMETER							
		1/4"	5/16"	3/8"	7/16"	1/2"	9/16"	5/8"	3/4"
 CAP SCREW	S.A.E. 2 STEEL	5	11	20	30	50	70	100	170
 CAP SCREW	S.A.E. 5 STEEL	8	17	30	50	75	110	150	270
 CAP SCREW	S.A.E. 8 STEEL	12	24	45	70	105	155	210	375

Torques are in ft - lbs.

Torques shown are for National Coarse Thread Plain or Zinc plated fasteners carrying residual oil of Manufacture.